

PARENTS STOCK

**Management
Handbook**

2013



This Handbook

The purpose of this Handbook is to help Aviagen's customers to optimize the performance from their parent stock. It is not intended to provide definitive information on every aspect of parent stock management, but to draw attention to important issues, which if overlooked or inadequately addressed, may depress flock performance. The management techniques contained within this Handbook have the objectives of maintaining flock health and welfare, and achieving good flock performance.

Performance

This Handbook summarizes best practice management for parent stock. The most common management strategy worldwide is for birds to receive first light stimulation after 21 weeks (147 days) of age and achieve 5% production at 25 weeks of age, as this gives distinct advantages in early egg size, chick number and broiler chick quality. However, poultry production is a global activity and across the world, differing management strategies may need to be adapted for local conditions.

The information presented is a combination of data derived from internal research trials, published scientific knowledge, and the expertise, practical skills and experience of the Aviagen Technical Transfer and Technical Service Teams. However, the guidance within this Handbook cannot wholly protect against performance variations which may occur for a wide variety of reasons. Aviagen therefore accepts no ultimate liability for the consequences of using this information to manage parent stock.

Technical Services

For further information, please contact your local Aviagen Technical Service Manager or Technical Department or access www.aviagen.com online.

Using this Handbook

Finding a Topic

Blue tabs appear on the right-hand side of the Handbook. These tabs allow readers immediate access to those sections and topics in which they are particularly interested.

The Table of Contents gives the title and page number of each section and subsection.

An alphabetical Keyword Index is given at the end of the Handbook.

Key Points

Where appropriate, key points have been included which emphasize important aspects of husbandry and critical management procedures, which if not implemented correctly, may have a negative impact on performance. These key points are written in red.

Performance Objectives

Supplements to this Handbook contain performance objectives that should be achieved with good management practices, environmental and health control.

Nutrition Specifications

Nutrition Specifications are also available as supplements to this Handbook.

Table of Contents

5	Introduction
6	Key Management Timetable
	Section 1 - Rearing (0-105 days/0-15 weeks)
9	Management Requirements for Males and Females During Rear
10	Chick Management
23	Equipment and Facilities
29	Grading to Manage Uniformity
30	Grading Procedures
43	Flock Management After Grading (Post 28 Days)
	Section 2 - Management into Lay (15 Weeks to Peak Production)
47	From 105 Days (15 Weeks) to Light Stimulation
47	Management Considerations
57	Management of Females Post Light Stimulation Until 5% Production
57	Management Considerations
58	Floor Eggs
59	Management of Females from 5% Hen-day Production until Peak Egg Production
59	Management Considerations
61	Feed Clean-up Trends
61	Egg Weight and Feed Control
63	Management of Males Post Light Stimulation until Peak Egg Production
63	Feeding Considerations
65	Mating Ratio
65	Over-mating
	Section 3 - Management in Lay (Peak to Depletion)
67	Management of Females After Peak Production Through to Depletion
67	Factors for Post-peak Management
69	Procedures
69	General Guidelines for Post-peak Feed Reductions Based on Target Performance Characteristics
73	Monitoring Feed Reduction
75	Feed Reductions and Environmental Temperature
76	Management of Males after Peak Production Through to Depletion
76	Procedures
	Section 4 - Monitoring Broiler Breeder Growth
77	Monitoring Broiler Breeder Growth
77	Body Weight Weighing Methods
79	Methodology for Sample Weighing
79	Procedures for Manual Scales
82	Procedures for Electronic Scales
82	Notes on Sample Weighing of Males
83	Note on Sample Weighing for Females
83	Inconsistent Weight Data

Section 5 - Assessment of Bird Physical Condition

- 85** **Assessment of Bird Physical Condition**
- 85 Assessing Bird Condition
- 86 Assessment of Male Condition
- 94 Assessment of Female Condition

Section 6 - Care of Hatching Eggs on Farm

- 99** **Care of Hatching Eggs**
- 99 Why Do Hatching Eggs Need Care?
- 100 The Egg's Protection System
- 102 Best Practice for Care of Hatching Eggs

Section 7 - Environmental Requirements

- 107** **Housing**
- 107 Farm Location and Design
- 109 House Design
- 111** **Ventilation**
- 111 Open-sided/Natural Ventilation
- 112 Negative Pressure Ventilation Systems (Controlled Environment Housing)
- 113 Minimum Ventilation
- 116 Transitional Ventilation
- 117 Tunnel Ventilation
- 121** **Lighting**
- 121 Lighting During Brooding
- 121 Lighting Programs and Housing Type
- 131 Wavelength (Light Color) and Lamp Type

Section 8 - Nutrition

- 133** **Nutrition**
- 133 Broiler Breeder Nutrition
- 133 Supply of Nutrients
- 137 Feeding Programs and Diet Specifications
- 140 Feed Manufacturing
- 142 Water

Section 9 - Health and Biosecurity

- 143** **Health and Biosecurity**
- 143 The Relationship Between Management, Disease Expression, and Bird Welfare
- 143 Hygiene Management
- 149 Water Quality
- 151 Dead Bird Disposal
- 152 Health Management
- 155 Health Monitoring Programs

Appendices

157	Appendix 1 - Records
159	Appendix 2 - Useful Management Information
161	Appendix 3 - Conversion Tables
164	Appendix 4 - Example of Manual Calculations for Grading
168	Appendix 5 - Calculations for Ventilation Rates
171	Appendix 6 - Dew Point or Condensation Table
172	Appendix 7 - Nutrient Composition of Some Commonly Used Feed Ingredients
173	Appendix 8 - Trouble Shooting - Vitamin Deficiency
174	Appendix 9 - Additional Sources of Management Information

Keyword Index

175	Keyword Index
-----	---------------

Introduction

Aviagen produces a range of genotypes suitable for different sectors of the broiler market. All Aviagen products are selected for a balanced range of parent stock and broiler characteristics. This allows our customers to select the product that best meets the needs of their particular operation.

As parent stock, all Ross genotypes are selected to produce the maximum number of vigorous day-old chicks by combining high egg numbers with good hatchability and fertility. This is achieved by mating together male lines which are fast growing, feed efficient, and have high meat yield, with female lines which are selected for the same broiler characteristics, and to lay high numbers of eggs.

This Handbook summarizes best practice parent stock management for Ross 308 and Ross 708 parent stock, taking into account the ongoing selection for improved broiler traits.

Key Management Timetable

The critical age objectives for parent stock are summarized in the table below.

Age (days)	Action
Before chick delivery	<p>Pre-heat the house. Temperature and relative humidity (RH) should be stabilized for at least 24 hours, prior to the chicks being delivered.</p> <p>Ensure good biosecurity. Pathogens can survive in the surrounding environment even before the chicks have been placed. Biosecurity before chick delivery is equally, if not more, important than biosecurity after chick arrival.</p> <p>All housing and equipment should be cleaned and disinfected and efficacy of the biosecurity operations verified prior to chick placement.</p>
On chick arrival	<p>Achieve optimum environmental temperature. This is critical for stimulating both appetite and activity.</p> <p>Establish a minimum ventilation rate. This will ensure that fresh air is supplied to the chicks, help to maintain temperature and relative humidity (RH) and allow sufficient air exchange to prevent the accumulation of harmful gases.</p> <p>Monitor chick behavior to ensure that temperature is satisfactory.</p> <p>Bulk weigh a sample of chicks.</p>
0-7	<p>Develop appetite from good brooding practice.</p> <p>Ensure adequate drinker and feeder space, provide good quality feed and maintain optimum temperatures.</p> <p>Use crop fill assessment as an indication of appetite development.</p> <p>Monitor bird behavior.</p>
7-14	<p>Achieve target body weights.</p> <p>Obtain body-weight sample. A bulk weighing of birds is required at 7 and 14 days of age. A minimum 2% sample or 50 birds (whichever is larger) should be weighed from each population. Where possible, provide a constant (8-hour) daylength by 10 days of age. In open-sided houses, daylength will depend on the placement date and the natural daylength patterns.</p> <p>If 14-day (2-week) body weights for previous flocks have regularly been below target, a longer daylength can be provided until 21 days (3 weeks) of age to help stimulate feed intake and improve body-weight gain.</p>
14-21	<p>Start recording individual body weights between 14 and 21 days (2 and 3 weeks) of age. This information is required to calculate body-weight uniformity (CV%).</p>
28	<p>Grade males and females at 28 days (4 weeks).</p> <p>After grading, revise body-weight profiles to ensure that birds achieve target body weights by 63 days (9 weeks).</p>

Age (days)	Action
28-63	<p>If necessary, adjust daily feed allocation for the male and female populations to achieve any revised body-weight targets, and maintain uniformity.</p> <p>Monitor and record body weight weekly.</p> <p>The main focus during this period is to achieve good skeletal uniformity and correctly control the growth within each graded population.</p>
63	<p>Re-examine graded population weights in relation to the body-weight target. Combine populations that are of similar weight and feed intake.</p> <p>If populations are not following the target profile, a new target body-weight line should be drawn.</p> <p>For populations that are over the target weight a new target line should be drawn parallel to the target.</p> <p>Populations that are under the target should gradually be brought back to target by 105 days (15 weeks).</p> <p>Movement of birds between populations should stop.</p>
63-105	<p>If necessary, adjust daily feed allocation for the male and female populations to achieve the target or any revised body-weight targets, and maintain uniformity.</p> <p>Monitor and record body weight weekly.</p> <p>The main focus during this period is to correctly control the growth within each graded population.</p>
105	<p>Re-examine body weights in relation to target. Revise profiles as necessary, in the same way that was completed at 63 days (9 weeks) of age.</p> <p>Remove any sexing errors as they are identified.</p>
105-161	<p>Achieve correct weekly body-weight gains by ensuring the appropriate feed amounts are given, particularly from 105 days (15 weeks) onwards.</p> <p>All populations should achieve similar body weights by light stimulation. Significant variation in body weight between populations at this age will lead to production problems in lay.</p> <p>Monitor and record body weight weekly.</p>
126-147	<p>Remove remaining sexing errors.</p>
140	<p>Calculate and record the uniformity (CV%) of the flock to determine the lighting program.</p> <p>If the flock is even (CV less than or equal to 10%), follow the normal recommended lighting program.</p> <p>If the flock is uneven (CV greater than 10%), light stimulation should be delayed by 7 to 14 days (1 to 2 weeks).</p>

Age (days)	Action
147-161	<p>First light increase given (not before 147 days of age).</p> <p>Monitor and record body weight weekly.</p>
147-168	<p>Mating-up - the exact time of this will depend on the relative maturity of both males and females.</p> <p>Immature males should never be mated to mature females.</p> <p>If males are more mature than females, they should be introduced gradually.</p> <p>Monitor and record body weight weekly.</p>
168-175	<p>Introduce the breeder feed. From 5% hen-day production at the latest.</p>
161-196	<p>From first egg, increase feed amounts according to the rate of daily egg production, daily egg weight and body weight.</p> <p>Monitor and record body weight weekly.</p>
210-depletion	<p>Manage males by observing bird condition.</p> <p>Remove non-working males to maintain appropriate mating ratios.</p> <p>Monitor and record body weight.</p>
245-depletion	<p>Feed reduction should be started approximately 35 days (5 weeks) after peak production is achieved, which is generally at 252 days (36 weeks) of age.</p> <p>Feed intake should be reviewed weekly and any reductions in feed should be based on egg production, daily egg weight, egg mass, and body weight.</p>

BIRD HANDLING

It is important that all birds are handled in a calm and correct way at all times. All people handling birds (for catching, weighing, physical assessment, crop fill assessment, or vaccination) should be experienced and appropriately trained so that they can handle the birds with the care that is appropriate for the purpose, age, and sex of the bird.

Section 1 - Rearing (0-105 days/0-15 weeks)

Management Requirements for Males and Females During Rear

Objective

To meet the requirements of male and female parent stock during each stage of rearing, and to prepare them for sexual maturity.

Principles

Growing the Ross parent to the target growth curve in rear allows males and females to achieve optimum lifetime reproductive performance by ensuring that the birds grow and develop correctly. **Figure 1** shows the progression of bird growth and development over time. At different points in time, different organs and tissues will develop. Within each phase of growth, the flock manager should consider, and be aware of, the birds' priorities for growth at that time. Management and feed amounts must be adjusted in response to the birds' needs.

Figure 1: Bird growth and development.*

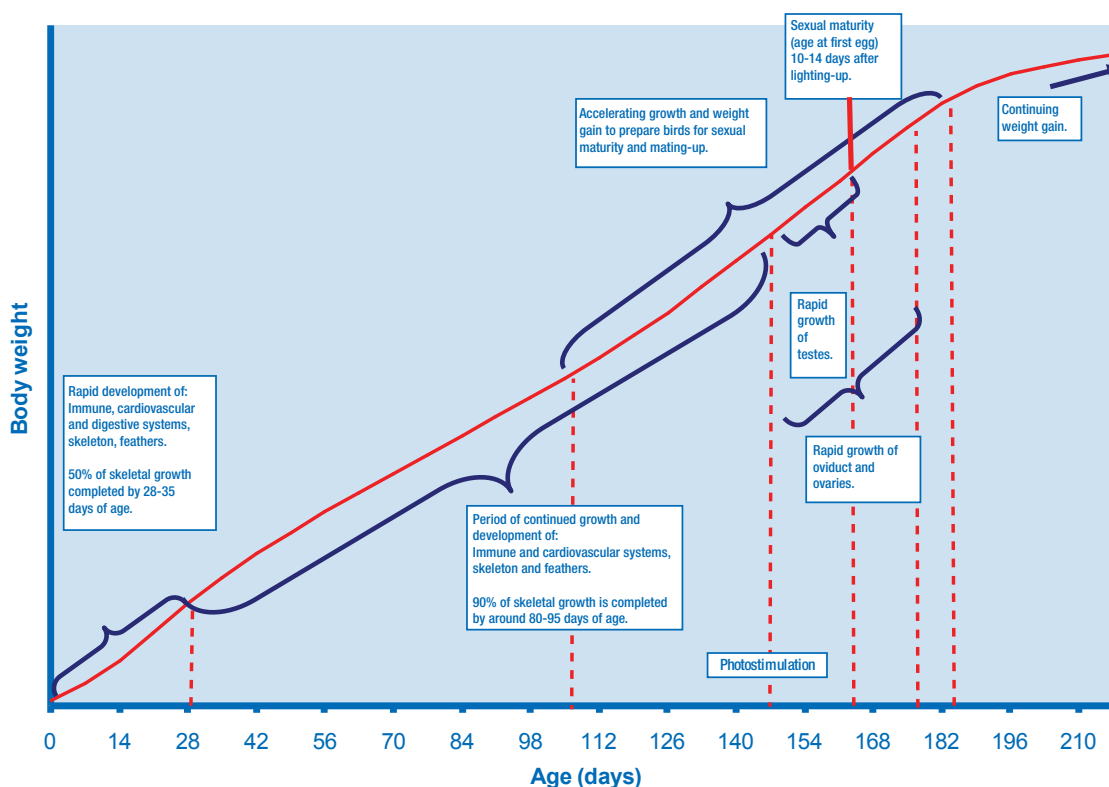

*The principles of growth and development will be the same for both males and females but absolute growth rates will be different.

Figure 2 details the important management considerations for each phase of bird growth illustrated in Figure 1.

Figure 2: Management progression.

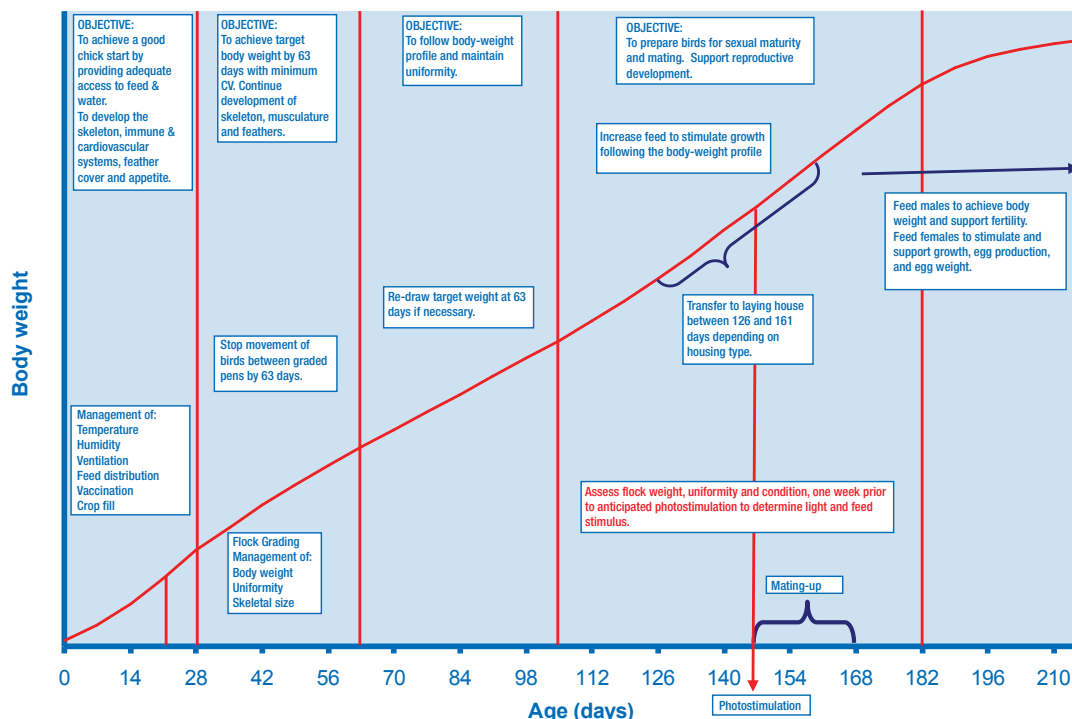

Males and females are reared separately from day-old to mating-up at 147-168 days (21-24 weeks) of age, but the principles for managing males and females in the rearing period are the same (apart from differences in body weight and feeding programs). The males form 50% of the breeding value of the flock and are therefore, just as important as females. So the management of the males requires the same attention to detail as that of the females. Growing the 2 sexes separately ensures that growth and uniformity can be controlled separately; providing more control over body weight and fleshing.

Chick Management

Providing chicks with a good start is essential for the subsequent health, welfare, uniformity and performance of the flock. Chick management should successfully establish the flock from day-old by developing feeding and drinking behavior, and providing the correct environmental and management conditions to adequately meet the requirements of the chick.

Chick preparations at the hatchery

Only in circumstances where it is anticipated that the welfare of the birds will be challenged should any preventative procedures be undertaken during chick processing in the hatchery.

In situations where bird welfare is likely to be compromised, procedures such as vaccination may be required. Where this is found to be necessary, it is essential that consultation with a veterinary advisor takes place and that only properly trained staff are employed and the correct equipment used. The necessity for any other processing procedures such as beak treatment must be regularly reviewed and investigations into the birds' environment and management conditions should be undertaken to avoid any unnecessary use of such procedures. Procedures undertaken during chick processing at the hatchery should be completed to the highest standard; variations in the quality of chick handling can lead to uniformity problems.

Animal welfare regulations and recommendations are regularly reviewed and updated with local variations. Regional and national regulations must be followed.

Planning before chick placement

The expected delivery date, time and number of chicks should be established with the supplier well in advance. This will ensure that the appropriate brooding set-up is in place and that chicks can be unloaded and placed as quickly as possible.

If the stock is being imported, appropriately trained personnel must be available to supervise and liaise with any customs clearance regulation formalities.

Chick placements should be planned so that chicks from different donor flocks can be brooded separately. Chicks from young donor flocks will achieve the standard body weights more easily if kept separate until the time of grading at 28 days (4 weeks) of age.

Chicks should be transported from the hatchery to the farm in an environmentally controlled vehicle (**Figure 3**). During transportation:

- Temperature should be adjusted so that the chick vent temperature is held between 39.4 – 40.5°C (103 - 105°F). Note that the required temperature control settings can vary between different vehicle designs.
- Relative humidity (RH) should be between 50 - 65%.
- A minimum of 0.71 cubic meters per minute (25 cubic feet per minute) of fresh air per 1,000 chicks should be supplied. Greater ventilation rates may be required if the truck is not air-conditioned and ventilation is the only method available to cool the chicks.

Figure 3: Typical controlled environment chick delivery vehicles.



The house set up at placement should plan for future grading procedures by leaving at least one pen empty (**Figure 4**) so that at grading, populations can be grown separately according to their requirements.

Figure 4: Example of a typical house set up pre-placement for 8,000 chicks, leaving one pen empty for grading at 28 days.

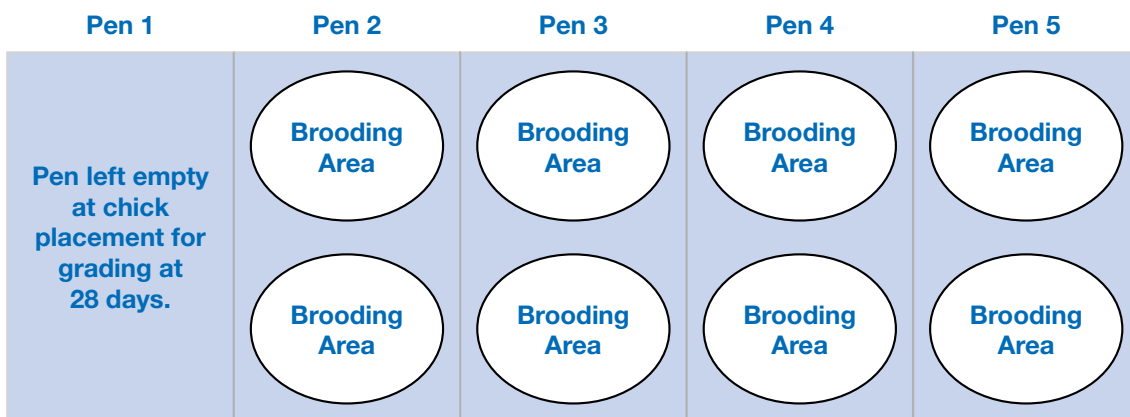

KEY POINTS

- Be prepared - know what is coming and when.
- Plan placements so that chicks from different aged donor flocks can be brooded separately.
- Chick holding and transport environment should be monitored closely to prevent the chicks from becoming chilled or over-heated.
- Plan areas for grading.

Farm preparations for chick arrival

Biosecurity

Individual sites should hold birds of a single age; managed on the principles of ‘all-in, all-out’. Vaccination and cleaning programs are easier and more effective on single-age sites, with consequent benefits in bird health and performance.

Houses, the areas surrounding the houses, and all equipment (including the water and feed systems) must be thoroughly cleaned and disinfected before the arrival of the litter material and chicks (**Figure 5**). A recommended hygiene program and efficacy testing procedure should be in place to ensure that the correct conditions are achieved at least 24 hours before the chicks arrive (see section on Health and Biosecurity for further information).

Figure 5: Good house cleaning practices. Power washing of the house, and a house after cleaning, which requires confirmation of acceptable bacteriological testing results before being restocked with litter material.



The area surrounding the house should be free from vegetation and be able to be easily cleaned (**Figure 6**).

Figure 6: Houses with a low biosecurity risk showing concrete areas and no vegetation around perimeter of the house.



Within the house itself, concrete floors are necessary to allow washing and effective litter management.

Vehicles, equipment, and people must be disinfected prior to entering the farm (**Figure 7**).

Figure 7: A vehicle being disinfected before entering a farm.



KEY POINTS

- Provide chicks with biosecure, clean housing.
- Control spread of disease by using single-age (all-in, all-out) housing.
- Follow a recommended hygiene program and have a testing procedure in place to test its effectiveness.

House preparation and layout

For chicks at placement, both correct air temperature and correct floor temperature are critical. Preheating the house before placement is therefore essential. Temperature (air and floor) and relative humidity (RH) should be stabilized for at least 24 hours prior to the chicks being placed. At placement the environmental conditions required are:

- An air temperature of 30°C/86°F (measured at chick height in the area where feed and water are positioned).
- A floor temperature of 28-30°C (82-86°F).
- A relative humidity of 60-70%.

Prior to the chicks arriving, litter material should be spread evenly to a depth of 8-10 cm (3-4 in). However, where floor feeding is to be practiced after brooding, litter depth should not exceed 4 cm (1.5 in). Litter depth may also be reduced where litter disposal is an issue. Where a thinner layer of litter is used it is essential that the correct floor temperature (28-30°C/82-86°F) is achieved prior to chick arrival. Providing excessive litter material (greater than 10 cm/4 in) can create a problem of litter movement leading to chicks becoming buried, especially if the litter is spread unevenly.

The choice of litter material is ultimately determined by cost and availability, but a good litter material should have the following properties:

- Good moisture absorption.
- Biodegradability.
- Good bird comfort.
- Low dust level.
- Freedom from contaminants.
- Consistent availability from a biosecure source.

At placement, and for the first 24 hours, chicks should not have to travel more than 1 m (3.3 feet) for access to water. Provide nipple lines with an allowance of 12 birds per nipple, or bell drinkers at a minimum of 8 drinkers per 1000 chicks. Twelve mini-drinkers or trays per 1000 chicks should also be available. The water supplied to the chicks should be at approximately 15 to 20°C (59 to 68°F). Do not give chicks chilled water.

After house cleaning and prior to chick delivery, the drinking water should be sampled at the source, at the storage tanks, and at the drinker points for bacterial contamination (see section on Health and Biosecurity for more information).

Any treatment of water with products (such as water soluble additives) that could encourage the growth of bacteria in the pipes should be followed by an effective water sanitation program. This should not affect the birds' performance, even subsequently, when they are in lay (refer to the section on Health and Biosecurity for further details).

Ensure that all chicks have easy access to feed. At placement, feed should be a sieved crumb (Figure 8) or mini pellet (2 mm [0.06 in] diameter) provided on supplementary feeder trays (1 per 80 chicks) and on paper to give a feeding area occupying at least 90% of the brooding area.

Figure 8: Example of a crumb of good physical quality.



During brooding the light intensity should be 80-100 lux (8-10 foot candles) in the area where the feed and water are positioned to encourage feeding and drinking behavior. The remainder of the house should be dimly lit (10-20 lux or 1-2 foot candles).

Spot brooding

In spot brooding, the heat source (canopy, pancake or radiant heaters) is local so chicks can move away to cooler areas and select for themselves a preferred temperature. Brooding rings are used to control early chick movement.

The layout for a spot brooding set up, which would be typical for 1,000 chicks on day one, is shown in Figures 9 and 10.

Figure 9: Example of a typical spot brooding layout (1,000 chicks).

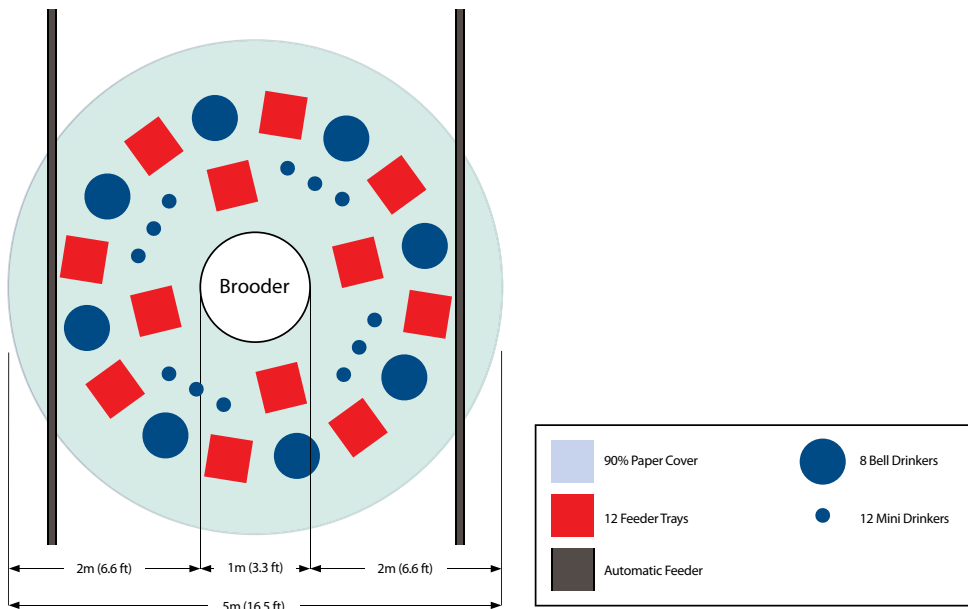

Chicks are placed in an area that gives an initial stocking density of around 40 chicks per m² (4 chicks per ft²).

Figure 10: Picture illustrating a good spot-brooding set-up.

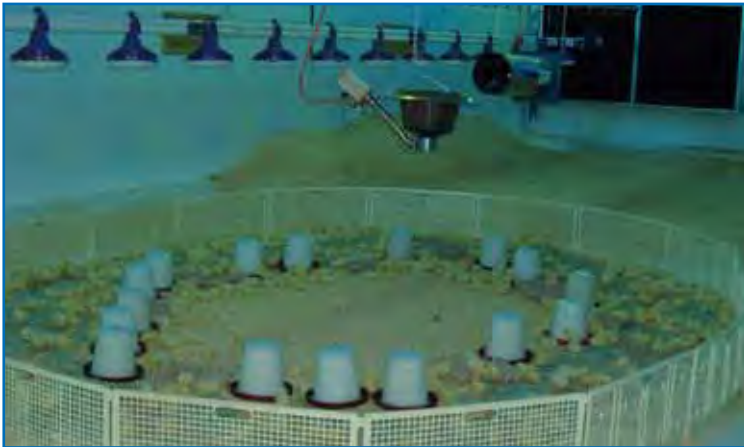

Whole-house brooding

In whole-house brooding (**Figures 11 and 12**), there is no temperature gradient within the house. House temperature is more constant and the ability of the chicks to move to a preferred temperature zone is limited.

The main heat source for whole-house brooding can be direct or indirect (using hot air), although supplementary brooders might also be provided.

Figure 11: Typical whole-house brooding layout for 1,000 chicks. In this situation, chicks are placed in a brooder surround.

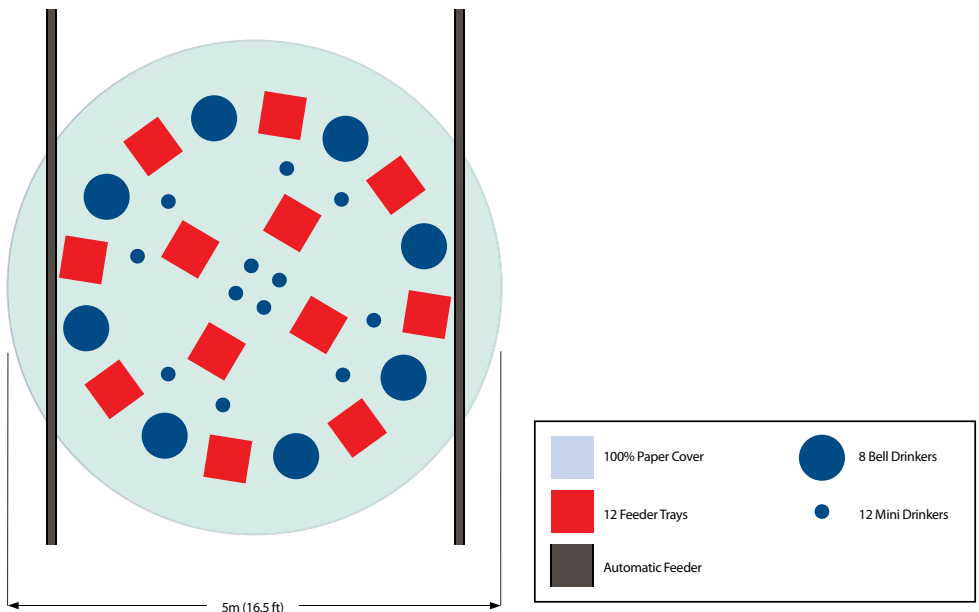

Whole-house brooding can also be used in part of the house. If this is done, then the whole house must be heated before releasing the chicks. This will encourage chick movement into the empty area of the house when access is given at around 7 days of age.

Figure 12: Picture illustrating a typical whole-house brooding set-up.



KEY POINTS

- Pre-heat the house and stabilize temperature and humidity at least 24 hours prior to chick arrival.
- Ensure cleanliness of water and litter.
- Arrange equipment to enable the chicks to reach feed and water easily.
- Position supplementary feeders and drinkers near the main feeding and drinking systems.

Chick arrival and placement

At placement the chicks should be placed into the brooding area as quickly as possible (**Figure 13**). The longer the chicks remain in the boxes, the more risk of dehydration, with resultant reduced welfare, poor chick starts, uniformity, and growth.

After placement, empty cardboard chick boxes should be removed and disposed of without delay. Plastic boxes should be returned for recycling after adequate disinfection protocols have been followed.

Figure 13: Plastic (on the left) and cardboard (on the right) chick boxes being delivered to a farm from a controlled environment vehicle.



After placement, chicks should be left to settle for 1 to 2 hours in their new environment. After this time, check that all chicks have easy access to feed and water and that environmental conditions are correct. Adjustments should be made to equipment and temperatures where necessary.

KEY POINTS:

- Unload chicks and place them quickly.
- Do not leave empty chick boxes lying around.
- Check feed, water, temperature and humidity after 1 to 2 hours and adjust where necessary.

Brooding management

Brooding is the first 7-10 days of a chick's life. Subsequent high levels of flock performance and welfare are dependant upon achieving high standards of management during this period.

It is important to replenish feed and water frequently. During the early stages of brooding (the first 3 days) the maximum daily feed allocation should be provided in small amounts given frequently (i.e. 5-6 times per day). This will avoid problems of food becoming stale and will encourage chicks to eat.

Open source drinkers (supplementary drinkers and bell drinkers) should be cleaned out and refreshed regularly as bacteria can multiply rapidly in open water at brooding temperatures. Supplementary drinkers supplied at placement should be gradually removed so that by 3-4 days of age all chicks are drinking from the automated drinking system.

For the first 2 days, chicks should be provided with 23 hours light and 1 hour dark. After the first 2 days, daylength should be gradually reduced so that it is down to a constant 8 hours by 10 days of age (see section on Lighting for more details). In open-sided houses, daylength will depend on date of placement and the natural daylength patterns.

During early brooding, chick movement is controlled by a brooding ring. The area contained by the rings should be expanded gradually from 3 days of age, and the rings removed completely by 5-7 days of age.

Temperature and RH should be monitored and recorded daily and appropriate adjustments to the environment made in response to chick behavior to ensure that environmental conditions are optimized.

The number of feeders and drinkers, and the heating capacity of the brooder, must be appropriate for stocking density to prevent adverse effects on performance from occurring.

Environmental control**Humidity**

Relative Humidity (RH) in the hatcher at the end of the incubation process will be high (approx. 80%). Houses with whole-house heating, especially where nipple drinkers are used, can have RH levels lower than 50%. Houses with more conventional equipment (such as spot brooders, which produce moisture as a by-product of combustion, and bell drinkers, which have open water surfaces) have a much higher RH - usually over 50%; but still lower than 80%. To limit the shock to the chicks, it is important that house RH levels in the first 3 days are between 60 and 70%. Chicks kept at appropriate humidity levels are less prone to dehydration and generally make a better, more uniform start.

RH within the house should be monitored daily using a hygrometer. If it falls below 50% in the first week, the environment will be dry and dusty. The chicks will begin to dehydrate and action should be taken to increase RH. RH can be increased by using the misters in the house (**Figure 14**) or a backpack portable sprayer to spray the walls with a fine mist.

Figure 14: Use of a mister to increase RH during brooding.



Temperature

Optimal temperature (and humidity) is essential for health and appetite development. In both spot and whole-house brooding systems the objective is to stimulate appetite and activity as early as possible. As birds cannot regulate their own body temperature until 12-14 days of age, provision of the correct environmental temperature and adjusting environmental temperature appropriately in response to bird behavior is critical.

A temperature guide appropriate for the recommended RH of 60-70% is given in **Table 1**. With whole-house brooding particular attention must be paid to monitoring and controlling house temperature and humidity, as the ability of chicks to move to a preferred temperature zone is limited.

With spot brooding, temperature gradients are created within the house. **Figure 15** shows the temperature gradients surrounding the spot brooder. These are marked A (brooder edge) and B (2 m [6.6 ft] from brooder edge). Respective optimum temperatures are shown in **Table 1**.

Figure 15: Spot brooding temperature gradients.

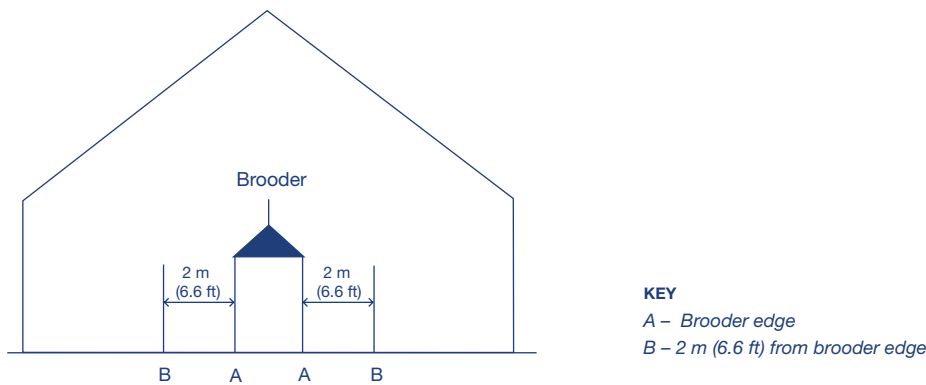

Table 1: Recommended temperature guide at an RH of 60-70%.

Age (days)	Whole-House Brooding Temp °C (°F)	Spot Brooding (Refer to Figure 15)	
		Edge of Brooder (A) Temp °C (°F)	2 m (6.6 ft) from Edge of Brooder (B) Temp °C (°F)
Day-old	30 (86.0)	32 (89.6)	29 (84.2)
3	28 (82.4)	30 (86.0)	27 (80.6)
6	27 (80.6)	28 (82.4)	25 (77.0)
9	26 (78.8)	27 (80.6)	25 (77.0)
12	25 (77.0)	26 (76.8)	25 (77.0)
15	24 (75.2)	25 (77.0)	24 (75.2)
18	23 (73.4)	24 (75.2)	24 (75.2)
21	22 (71.6)	23 (73.4)	23 (73.4)
24	21 (69.8)	22 (71.6)	22 (71.6)
27	20 (68.0)	20 (68.0)	20 (68.0)

Interaction between temperature and humidity (RH)

The temperature experienced by the chick is dependent on dry bulb temperature and RH. Birds lose heat to the environment by evaporation of moisture from the respiratory tract and by heat (not evaporation) passing through the skin. At high RH, less evaporative loss occurs increasing the animals' apparent temperature. High RH, therefore, increases apparent temperature at a particular dry bulb temperature, whereas low RH will decrease apparent temperature.

The temperature profile given in **Table 1** assumes an RH in the range of 60-70%, but if RH differs from this, optimum temperature may need to be altered accordingly. **Table 2** shows the dry bulb temperature required to achieve the target temperature profile in situations where RH differs from the target of 60-70%. If RH is outside the target range house temperature at chick level can be adjusted to match that given in **Table 2**.

Table 2: Dry bulb temperatures required to achieve equivalent temperatures at varying RH. Dry bulb temperatures at the ideal RH at an age are colored red.

Age (days)	Dry Bulb Temperature at RH%* °C (°F)				
	40	50	60	70	80
Day-old	36.0 (96.8)	33.2 (91.8)	30.8 (84.4)	29.2 (84.6)	27.0 (80.6)
3	33.7 (92.7)	31.2 (88.2)	28.9 (84.0)	27.3 (81.1)	26.0 (78.8)
6	32.5 (90.5)	29.9 (85.8)	27.7 (81.9)	26.0 (78.8)	24.0 (75.2)
9	31.3 (88.3)	28.6 (83.5)	26.7 (80.1)	25.0 (77.0)	23.0 (73.4)
12	30.2 (86.4)	27.8 (82.0)	25.7 (78.3)	24.0 (75.2)	23.0 (73.4)
15	29.0 (84.2)	26.8 (80.2)	24.8 (76.6)	23.0 (73.4)	22.0 (71.6)
18	27.7 (81.9)	25.5 (77.9)	23.6 (74.5)	21.9 (71.4)	21.0 (69.8)
21	26.9 (80.4)	24.7 (76.5)	22.7 (72.9)	21.3 (70.3)	20.0 (68.0)
24	25.7 (78.3)	23.5 (74.3)	21.7 (71.1)	20.2 (68.4)	19.0 (66.2)
27	24.8 (76.6)	22.7 (72.9)	20.7 (69.3)	19.3 (66.7)	18.0 (64.4)

*Temperature calculations based on a formula from Dr. Malcolm Mitchell (Scottish Agricultural College).

If behavior indicates that the chicks are too cold or too hot, the house temperature should be adjusted appropriately.

Monitoring humidity and temperature

Temperature and humidity should be monitored at least twice a day for the first 5 days and then daily thereafter. Measurements of temperature and humidity should be taken at chick level.

Figure 16 indicates the correct positioning of automatic temperature/humidity sensors (above bird head height).

Figure 16: Correct location for temperature/humidity sensors.



Conventional thermometers should be used to cross-check the accuracy of electronic sensors controlling automatic systems.

Ventilation

Ventilation without drafts is required during the brooding period to:

- Maintain temperatures and RH at the correct level.
- Replenish oxygen.
- Remove excess moisture, carbon dioxide and noxious gases produced by the chicks and possibly the heating system.

Poor air quality due to under ventilation at brooding may cause damage to the chicks lung surface, making birds more susceptible to respiratory disease. Because young chicks are prone to wind chill effects, the actual air speed at floor level should not be more than 0.15 m/sec (30 ft/min). Any ventilation applied during brooding should not impact bird temperature.

KEY POINTS

- Achieve a humidity level of 60-70% for the first 3 days.
- Temperature is critical during brooding and should be maintained as recommended.
- Adjust temperature settings accordingly if RH increases above 70% or falls below 60%.
- Monitor temperature and humidity regularly. Check automatic equipment with manual measurements at chick level.
- Establish a minimum ventilation rate from day one to provide fresh air and remove waste gases.
- Avoid drafts.
- Respond to changes in chick behavior.

Monitoring chick behavior

Temperature and humidity should be monitored daily, but by far the best indicator of correct brooding temperatures is frequent and careful observation of chick behavior.

Spot brooding behavior

With spot brooding, correct temperature is indicated by chicks being evenly spread throughout the brooding area as shown in **Figure 17**. Uneven chick distribution is a sign of incorrect temperature or drafts.

Figure 17: Bird distribution under brooders. The brooder is the light blue circle in the center of each diagram.

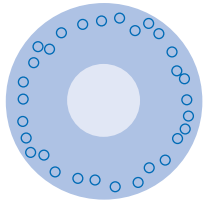

Temperature too high
 Chicks make no noise
 Chicks pant, head and wings droop
 Chicks away from brooder

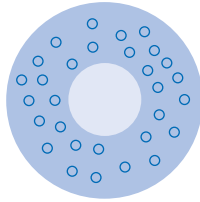

Temperature correct
 Chicks evenly spread
 Noise level signifies contentment

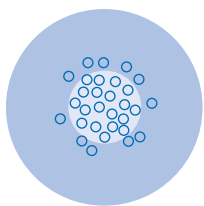

Temperature too low
 Chicks crowd to brooder
 Chicks noisy, distress-calling

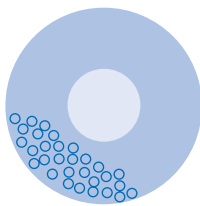

Draft
 This distribution requires investigation
 Influenced by draft,
 uneven light distribution,
 external noises

Whole-house brooding

In whole-house brooding monitoring chick behavior is less easy, because there are no obvious heat sources. Often, the chicks' vocalizations may be the only indication of distress. Given the opportunity birds will congregate in areas where the temperature is closest to their requirements. If environmental conditions are correct chicks will tend to form groups of 20-30, with movement between the groups, and continuous feeding and drinking will occur. Different distributions of chicks in whole-house brooding at different temperatures are given in **Figure 18**.

Figures 18: Typical behavior of chicks in whole-house brooding (without chick surround) at different temperatures.

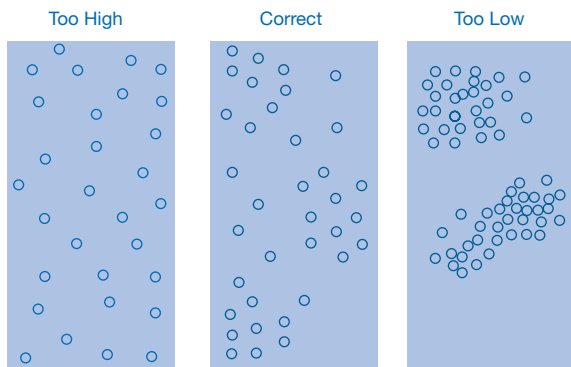

KEY POINTS

- Chick behavior should be closely and frequently observed.
- Adjustments to house environment should be made in response to chick behavior.

Chick start assessment

In the period immediately after the chicks are first introduced to feed and water they are hungry which means that they should eat well and fill their crops. Assessment of crop fill at key times after placement is a useful means of determining appetite development and checking that all chicks have found feed and water. Crop fill should be monitored during the first 48 hours, but the first 24 hours are the most critical. An initial check 2 hours after placement will indicate if chicks have found feed and water. Subsequent checks at 8, 12, 24 and 48 hours after arrival on the farm should also be made to assess appetite development. To do this, samples of 30-40 chicks should be collected at 3 or 4 different places in the house (or per surround where spot brooding is used). Each chick's crop should be felt gently. In chicks that have found feed and water, the crop will be full, soft and rounded (**Figure 19**). If the crop is full, but the original texture of the crumb is still apparent, the bird has not yet consumed enough water. Target crop fills are given in **Table 3**.

Figure 19: Crop fill after 24 hours. The chick on the left has a full, rounded crop while the chick on the right has an empty crop.

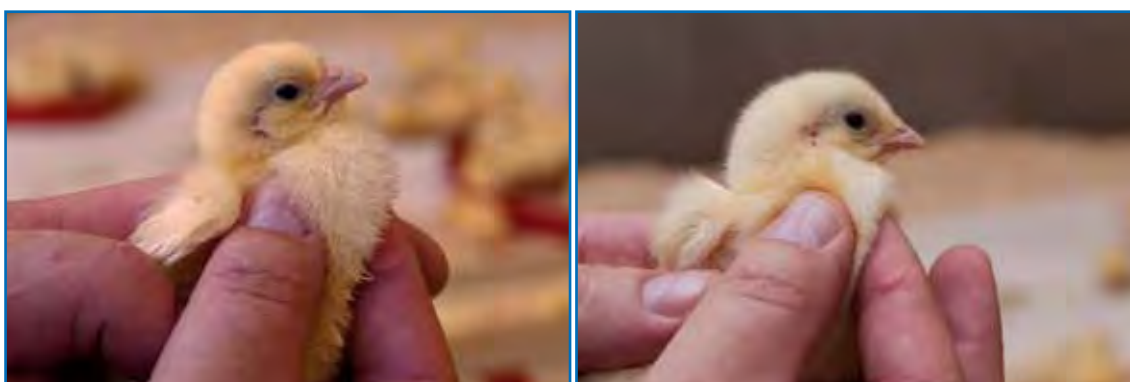

Table 3: Target crop fill assessment guidelines.

Time of Crop Fill Check After Placement	Target Crop Fill (% of Chicks with Full Crops)
2 hours	75
8 hours	>80
12 hours	>85
24 hours	>95
48 hours	100

KEY POINTS

- Monitor crop fill during the first 48 hours after chick placement.
- Achieve good early crop fill. If target levels of crop fill are not being achieved then something is preventing the chicks from feeding and drinking, and action must be taken to resolve this.

Equipment and Facilities

Optimal flock welfare and performance can only be achieved if the correct amount of floor and feeder space, and number of drinkers for bird age and size are given throughout the life of the flock.

Stocking density

Stocking density, in part, determines the biological output of the flock. Increases in stocking density must be accompanied by appropriate adjustments in environment and management conditions to prevent reductions in biological performance.

Recommended stocking densities during rear are given in **Table 4**. The range of figures quoted represents the variation in conditions from tropical (lower densities) to temperate (higher densities) climates and are intended as a guide. Actual stocking density will depend on:

- Target live weight at transfer/depletion.
- Climate and season.
- Type, system and quality of housing and equipment; particularly ventilation.
- Local legislation.
- Quality Assurance/Certification requirements.

Table 4: Recommended stocking densities during rear (from 14 days onwards).

Rearing 14-105 days (2-15 weeks)	
Males Birds/m ² (ft ² /bird)	Females Birds/m ² (ft ² /bird)
3-4 (2.7-3.6)	4-7 (1.5-2.7)

Prior to 14-21 days of age bird floor space allowance should be progressively increased until the levels given in **Table 4** are reached.

When determining the appropriate stocking density the actual available bird space should be taken into account. For example, day-old-to-depletion housing systems can incorporate equipment during the rearing stage such as nest boxes, which will reduce the available bird floor area.

KEY POINTS

- Make sure that each bird has adequate floor space for the environment. If the environment and/or housing conditions experienced by the bird are not optimal the stocking density will need to be reduced.
- Follow the local legislation.
- If stocking density is increased, then ventilation, feeders and drinkers must also be increased appropriately.
- When calculating floor space make sure necessary reductions are made for any equipment in the bird area.

Feeder space

Bird uniformity and performance will be negatively affected if there is not enough feeding space for the number of birds in the house. Recommended feeder space for males and females is given in **Table 5**.

Table 5: Recommended feeding space.

MALES		
Feeding Space		
Age (days)	Track Feeder cm (in)	Pan Feeder cm (in)
0-35 days	5 (2)	5 (2)
36-70 days	10 (4)	9 (3.5)
71-105 days	15 (6)	11 (4)

FEMALES		
Feeding Space		
Age (days)	Track Feeder cm (in)	Pan Feeder cm (in)
0-35 days	5 (2)	4 (2)
36-70 days	10 (4)	8 (3)
71-105 days	15 (6)	10 (4)

Track and pan feeders should be positioned a minimum of 1 m (3.3 ft) apart to allow uniform and unobstructed bird access to the feeder (**Figures 20 and 21**).

Figure 20: Uniform distribution of females around a track feeder when adequate feeder space is given.



Figure 21: Uniform distribution of males round a pan feeder when adequate feeding space is given.



KEY POINTS

- Bird uniformity will be negatively affected if feeding space and/or bird distribution is limited.
- Ensure there is enough feeding space for the number of birds in the house.
- Spacing between feeders should allow the birds easy access.

Feeding management

The first step in feeding management is to install the correct number of feeders providing adequate feeder space so all birds can eat simultaneously (**Table 5**). This provides uniform feed distribution and prevents overcrowding at feeders.

Where track feeding or pans are used, birds should be gradually introduced to the automated system from 8 days of age onwards. This process should be completed over a 2-3 day period, during which time the amount of feed in the automated feeding system should be gradually increased so that birds become accustomed to the noise of the feeders and associate this with feeding. During this transitional period, manual feeding by hand should continue.

If more than one feeder track is used, then tracks should operate in opposite directions. All feed should be distributed to each population within 3 minutes. If feed distribution is a problem, distribution time can be reduced by placing a supplementary bin, with sufficient feed to fill half of the track, halfway round the feeder loop.

Pan feeders provide good feed distribution if managed properly. Pan feeding systems remain charged at all times to allow the system to work correctly and pan feeders must be checked regularly to make sure that all pans are receiving feed and that lines remain charged (full of feed).

Feed depth, distribution time and clean-up time should be monitored routinely at several points around the house. This is to ensure that feed distribution is correct, that all birds have access to the feeders at the same time, and that the whole feeding system is being filled correctly.

Feeder height should be adjusted regularly with bird age and growth. Correct feeder height at a given age should minimize feed spillage, optimize bird access, and prevent the feeders from becoming contaminated with litter.

Floor feeding - scattering high quality pellets onto the litter either with spin feeders or by hand broadcasting (**Figure 22**) - is an increasingly popular alternative to tracks and pans. This method offers rapid and even distribution of feed over a wide area and can improve flock uniformity, litter condition, and leg health.

Figure 22: Floor feeding using either spin feeders or hand broadcasting.



For floor feeding, pen population size should be no more than 1000-1500 birds (depending on the pen shape/spinner type). Having feed of good physical quality is particularly important with floor feeding and a pellet with 2.5 mm (.09375 in) diameter and 3-4 mm (0.125 in) in length should be used. For floor feeding, the transition to pellet feeding must be well managed. Crumb should be fed on feeder trays on the floor until approximately 14 days of age. Crumb and pellet should be mixed and fed on the floor/feeder trays for at least 2 days before birds are given 100% pellets at around 16 days of age when mechanical spin feeding begins.

No matter which feeding system is used, adjustments to feed provision must be made when problems (such as birds becoming overweight or underweight) are detected. As the flock increases in age and body weight, feed increases must support the greater nutrient requirements of the heavier birds.

Ideally, feed should not remain on the farm for more than a week. Feed bins should always remain covered and be in good condition to prevent water entry. Any feed spills should be cleaned up promptly.

Use a standard weight to check the accuracy of the feed scales daily before use. Save a sample of feed from each delivery and store it in a cool, dry place. If a problem develops the feed can then be analyzed.

A visual assessment of every feed delivery should be made. The feed should be assessed on its physical quality, color, appearance, and smell. For mash, check that there is good distribution of raw materials throughout the feed.

Physical quality of the feed is important and levels of fines should not exceed 10% for pellets/crumbs or 25% for mash. Increased levels of fines will have a negative impact on performance. The level of fines within a feed can be measured using a feed shaker sieve.

KEY POINTS

- Feed distribution should take a maximum of 3 minutes.
- Manage the transition to automated feeding systems carefully.
- Ensure good pellet quality when using floor feeding.
- Monitor feed quality.
- Avoid storing feed for more than 7 days.
- Make adjustments to feed intake when necessary.

Drinker space and height

Recommended drinking space post-brooding is detailed in **Table 6** below. When adequate drinker space is provided, bird distribution around the drinkers will be uniform (**Figure 23**).

Table 6: Recommended drinking space requirements post brooding during rearing.

Type of Drinker	Drinker Space
Bell drinkers	1.5 cm (0.6 in)
Nipples	8-12 birds/nipple
Cups	20-30 birds/cup

Figure 23: Uniform bird distribution around drinkers when adequate drinker space is provided for bell, nipple, and nipple with cups.



Round bell drinkers should be checked for height daily and gradually adjusted so that the base of each drinker is level with the birds back by approximately 18 days onwards (**Figure 24**).

Figure 24: Correct height of bell drinker.

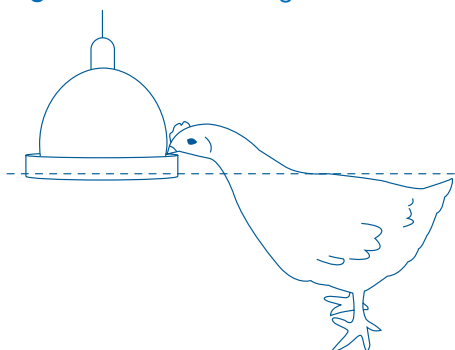

In the initial stages of brooding, the nipple lines should be placed at a height at which the bird is able to drink. The back of the chick should form an angle of 35-45° with the floor while drinking is in progress. As the bird grows, the nipples should be raised so that the back of the bird forms an angle of approximately 75-85° with the floor and so that the birds are stretching slightly for the water (**Figure 25**).

Figure 25: Correct height of nipple drinker.



Birds should be reared on the same drinking system as will be used in production.

Drinker management

Birds should have unlimited access to a clean, fresh water supply at all times. Any reductions in water intake or increased water loss can have a significant effect on the lifetime performance of the bird.

Water fit for human consumption is likely also to be fit for parent stock. Water from bore holes, open water reservoirs or poor quality public supplies can cause problems for bird performance and health. Details of water quality criteria for poultry are given in the section on Health and Biosecurity. A total water quality test should be completed at least once a year (more often if there are perceived water quality issues). Where bacterial counts are high the cause must be established and rectified as soon as possible. Treatment with chlorination (to give between 3 and 5 ppm) may be required to reduce bacterial load.

Where open sourced drinkers (such as supplementary chick drinkers or round bell drinkers) are used, bacterial contamination can increase rapidly. Therefore, regular and frequent cleaning is needed, especially with young chicks during the brooding stage.

Water consumption measurement is a useful means to monitor system failures (feed and water), monitoring health and tracking bird performance. At 21°C (69.8 °F), the birds will be consuming enough water when the ratio of water intake to feed intake is 1.6-1.8: 1 (water: feed; the lower ratio being for nipple drinkers and the higher for bell type drinkers). Water requirement will therefore vary with feed consumption.

Birds will drink more water at higher ambient temperatures. Water requirement increases by approximately 6.5% per degree centigrade over 21°C (69.8°F). In tropical areas, prolonged high temperatures can double daily water consumption.

KEY POINTS

- Birds should have continual access to fresh, clean, drinkable water.
- The measurement of water consumption by metering is a vital daily management practice.
- Check and adjust drinkers daily.
- Test the water supply regularly for bacteriological and mineral contaminants and take any necessary corrective action.

Introduction of perches

It is good management practice to install perches during the rearing period in order to train and stimulate females in nesting behavior (avoidance of floor eggs). Sufficient numbers of perches to provide 3 cm (1.2 in) per bird (sufficient for 20% of the birds to roost) should be placed in the females' rearing pens from 28 days of age, and is best carried out at the time of grading. **Figure 26** illustrates typical perch systems used for training; one uses slats, the other is an 'A' frame.

Installing perches during rear is also a useful management tool for training males in situations where water is positioned on the slats.

Figure 26: Perch systems used for training.



Grading to Manage Uniformity

Objective

A uniform flock is easier to manage than a variable one – birds in a similar physiological state will respond more uniformly to management factors. The purpose of grading, therefore, is to sort the flock into 2 or 3 sub-populations of different average weight so that each group can be managed in a way that will result in good whole flock uniformity at point of lay.

Principles

Variation in an animal population can be measured by the Coefficient of Variation, which is expressed as a percentage (CV%). CV% may be determined automatically at the point of sample weighing or calculated manually as shown in the Appendices. At placement, flock body weights should follow a normal distribution with a low variation. Within populations there is always natural variation, even at day-old. As birds grow, the variation within a flock will increase further due to the differential responses of individual birds to factors such as vaccination, disease, differing competitiveness for feed, etc. (Figure 27). This increased variation reduces overall flock performance and makes flock management much more difficult.

Figure 27: Estimated changes in flock uniformity through time as a result of natural variation where no flock grading has occurred at 28 days of age.

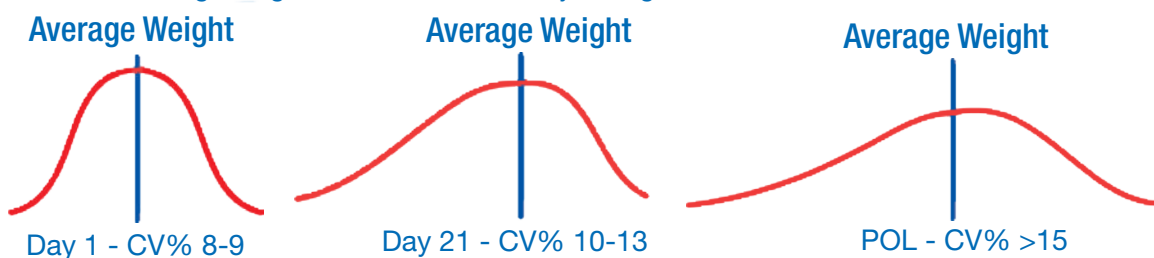

In general, as the shapes of the distribution curves show, the increase in variation is a result of an increased number of lighter birds within a flock. In order to create a uniform flock, smaller, lighter, birds should be identified, penned and managed separately (2-way grading). The benefits of doing this for flock uniformity (CV%) are illustrated in Figure 28.

Figure 28: Estimated changes in flock uniformity and distribution of body weights when the flock is graded at 28 days of age.

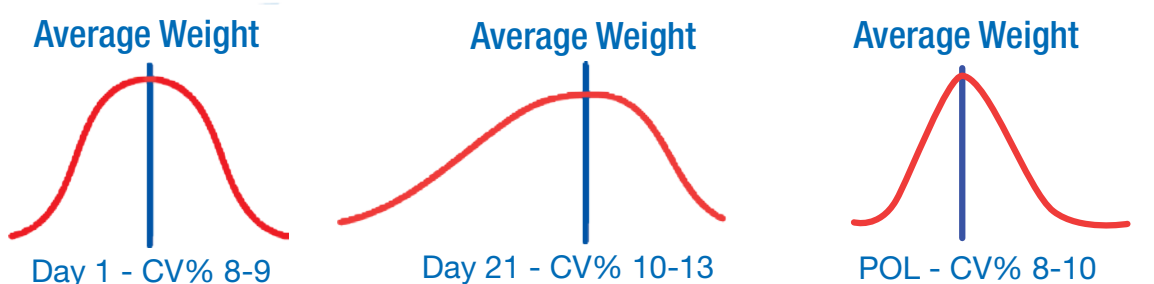

By grading a flock and managing populations of the same average weight separately, flock uniformity (CV%) can be improved and flock management will be easier as all birds will respond in a similar way to management factors such as light stimulation and increased feeding.

In some situations where the flock CV% has increased so that it becomes greater than around 12%, a grading of both lighter and heavier birds will be required (3-way grade).

Grading Procedures

Grading is best carried out when the flock is 28 days (4 weeks) old and when flock uniformity is usually within the range of CV = 10-14%. If completed later than this, the time available to restore flock uniformity (ideally by 63 days) is reduced, and the procedure is less effective.

A practical approach to grading involves segregation of the graded populations into pens or houses left empty at placement for this purpose. To allow for extreme cases (i.e. CV% >12), space allocated for both male and female flocks must be capable of being divided into 2 or 3 pens/populations. Where the entire population of a house is to be graded within that house, then ideally 1 or 2 adjustable partitions will be required to allow the flock to be segregated.

The actual grading procedure will largely depend on the farm/house design and management practices (e.g. flexibility of pen arrangements and feeding systems), and the uniformity of the flock at 28 days. There are 2 situations that need to be considered:

1. Grading when adjustable penning is available.
2. Grading when adjustable penning is not available (i.e. fixed penning).

Grading when adjustable penning is available

Table 7 gives the grading cut-off points (i.e. the percentage of birds that will be in each graded population), according to flock uniformity. These apply when adjustable penning is available.

Table 7: Grading cut-off points.

Flock Uniformity CV%	Percentage in Each Population after Grading			
	2 or 3-way grade	Light (%)	Normal (%)	Heavy (%)
10	2-way grade	20	~ 80 (78-82)	0
12	3-way grade	22-25	~ 70 (66-73)	5-9
14	3-way grade	28-30	~ 58 (55-60)	12-15

Two-way grade - pre-grade CV% below 12

Figure 29 represents a house where the pre-grading population has been split between 4 pens. One of the pens has been left empty, from placement, for the purpose of grading. In this example the flock size is 8,400 birds and 2,100 birds are housed in each populated pen at placement.

Figure 29: Pre-grade house set up for 2-way grade with adjustable penning.

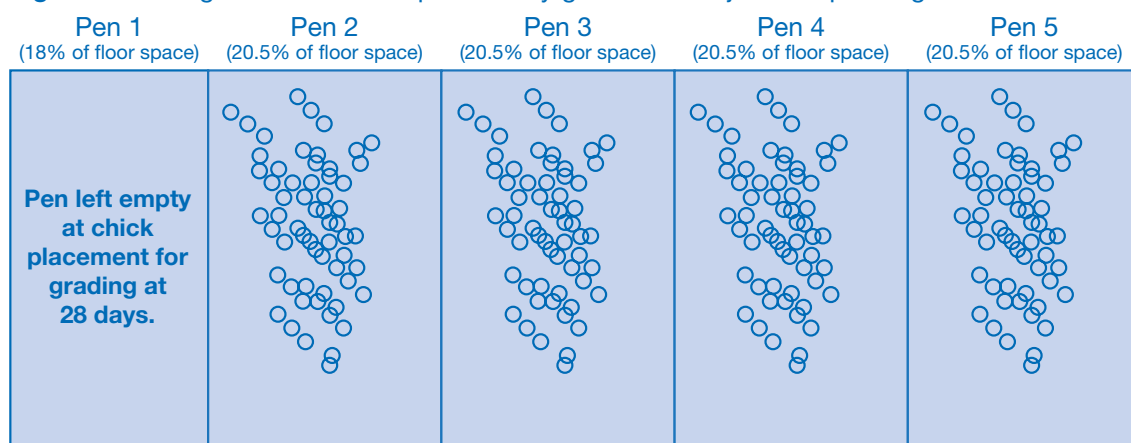

From each pen/population a random sample of birds should be caught in a catching pen and weighed. All birds caught in the catching pen need to be weighed (to avoid selective weighing); but as a minimum, the weights of 2% of the pen/population or 50 birds, whichever is greater, need to be recorded. In this example, a total of 103 birds have been weighed.

Aviagen’s preference is to use electronic scales which record and count individual weights, and automatically calculate the standard deviation and CV% of the population. The print-out produced from these scales (see **Figure 30**) can be used to establish the cut-off points for grading. If electronic scales are not available and weights are recorded manually, please refer to the example given in the Appendices.

Figure 30: Example of a print-out from an electronic scale for a 2-way grade adjustable penning (Ross 308 flock).

CURRENT DATA METRIC	
TOTAL WEIGHED:	103
AVERAGE WEIGHT:	0.435
DEVIATION:	0.045
C.V. (%):	10.2

Band limits	Total
0.340 to 0.359	3
0.360 to 0.379	6
0.380 to 0.399	8
0.400 to 0.419	11
0.420 to 0.439	19
0.440 to 0.459	20
0.460 to 0.479	12
0.480 to 0.499	11
0.500 to 0.519	9
0.520 to 0.540	4

Flock details	kg	lbs
Age	28	28
Target weight	0.450	0.99
Average weight	0.435	0.96
Total birds weighed	103	103

Based on this flock sampling data a two way grade is required as detailed below; i.e. flock CV% is below 12%.

Flock Uniformity	Percentage in each population after grading			
	CV%	2 or 3 way grade	Light %	Normal %
10	2 way grade	20	≈ 80 (78-82)	0
12	3 way grade	22-25	≈ 70 (66-73)	5-9
14	3 way grade	28-30	≈ 58 (55-60)	12-15

CURRENT DATA IMPERIAL	
TOTAL WEIGHED:	103
AVERAGE WEIGHT:	0.96
DEVIATION:	0.099
C.V. (%):	10.2

Band limits	Total
0.750 to 0.791	3
0.794 to 0.836	6
0.838 to 0.880	8
0.882 to 0.924	11
0.926 to 0.968	19
0.970 to 1.012	20
1.014 to 1.056	12
1.058 to 1.100	11
1.102 to 1.144	9
1.146 to 1.190	4

Cut off points and number of birds in each group:

	% of birds	No. of birds
Light Birds	20	21
Normal Birds	80	82

From the information recorded on the print-out the CV% of the flock has been calculated as 10.2%.

$$CV\% = \frac{\text{Standard Deviation}}{\text{Average Body Weight}} \times 100$$

As the CV% is under 12, a 2-way grade is required. The flock needs to be split into 2 populations; light and normal weight birds. The approximate percentage of birds required in each of the 2 populations is 20% light birds and 80% normal birds (Table 7).

To determine the cut-off point for the lightest birds (the weight below which birds are considered to be light) the following steps are taken.

1. The light population will be approximately 20% of the entire flock. Twenty percent of the total number of birds weighed is 21 (20% of 103).
2. The lightest 21 birds are in the weight range of 340 to 419 g (0.75 to 0.92 lbs) (colored orange in Figure 30).
3. A 'light' bird will therefore be anything less than or equal to 419 g (0.92 lbs) in weight.
4. The 'normal' bird population, which is the remaining 80% of the flock, are birds weighing 420 g (0.92 lbs) or over (shaded blue in Figure 30).

All birds in the flock now need to be reweighed and the light birds (anything less than or equal to 419 g or 0.92 lbs) removed and graded into the empty pen (Figure 31). The floor space of each pen will need to be adjusted to account for changes in the size of the graded populations.

Figure 31: Graded plan based on the body weight results given in Figure 30 (2-way grade with adjustable penning).

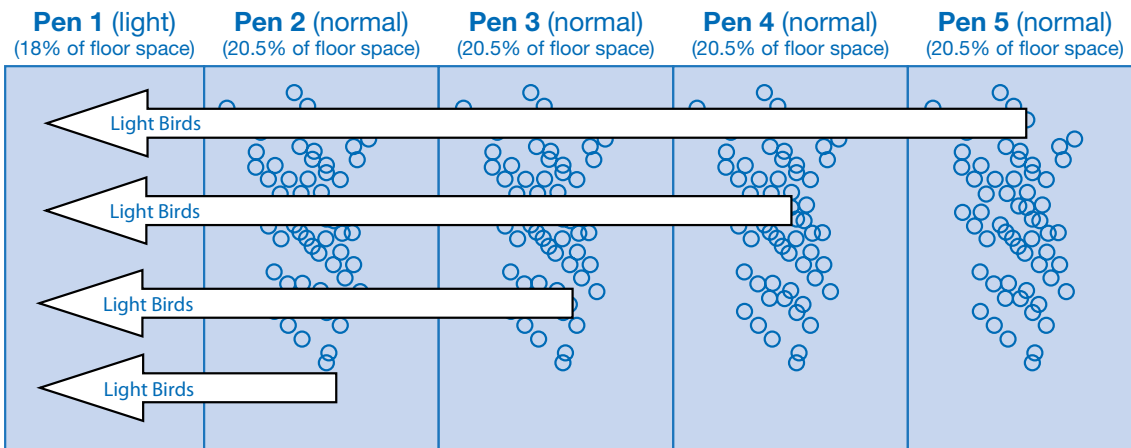

After grading, a sample of birds should be reweighed from each pen/population (a minimum of 2% or 50 birds whichever is greater) and the average weight, CV% and number of birds for each pen established (Figure 32).

Figure 32: Situation after a 2-way grade (adjustable penning).

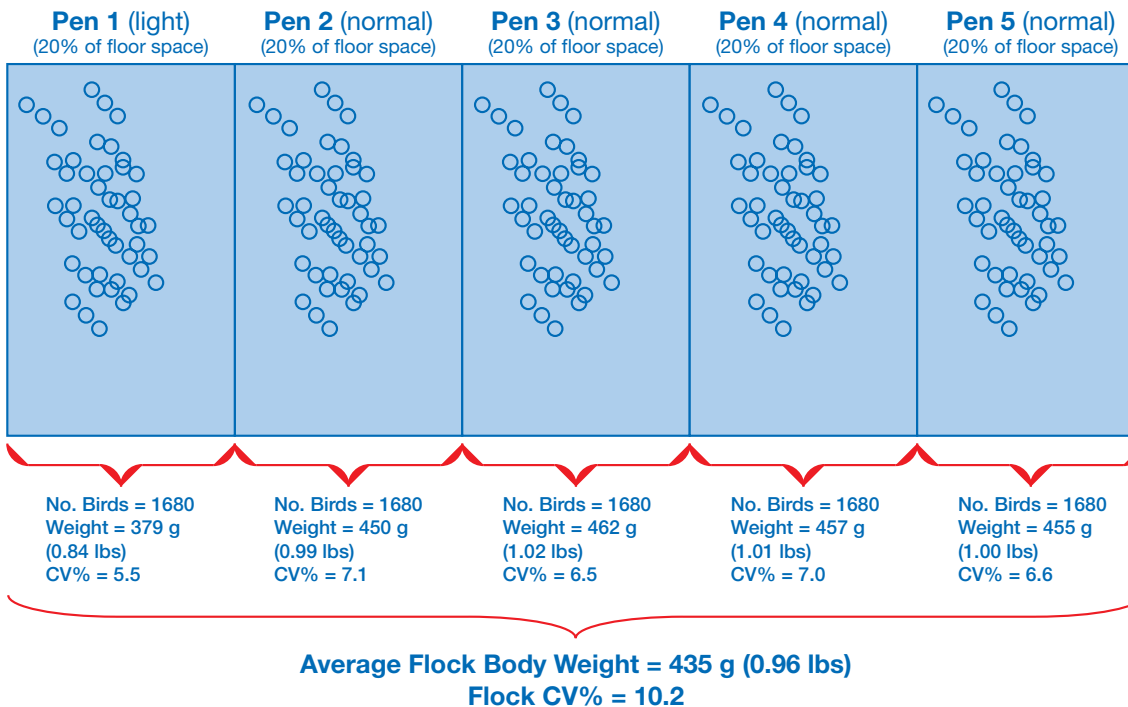

After grading the CV% for the 'light' and 'normal' pens will have been improved, but the overall flock CV% remains the same (Figure 32).

The average weight for the 'normal' pens should be similar and these pens may be treated as one population. However, the farm manager should be aware of the average weight of each individual pen and any sudden deviations from the planned target should be investigated.

The body weights from the 'light' and 'normal' pens should be plotted against target on a body weight target chart and the profile re-drawn where necessary to bring birds back onto target by 63 days (9 weeks) of age. Adjustments made in feed levels should be based on the deviation from target body weight. Refer to the section on Flock Management after Grading for more information.

Note that after grading, the light population may not need to receive an immediate increase in feed. Body weight will increase due to the reduced competition from the larger birds and so an initial increase in feed is not required.

Three-way grade; pre-grade CV% above 12

Figure 33 represents a house which has been split into 5 pens. The pre-grading population has been split between 4 pens, and one pen has been left empty, from placement, for the purpose of grading. The flock size is 8,400 birds and 2,100 birds are housed in each populated pen.

Figure 33: Pre-grade house set up for a 3-way grade with adjustable penning.

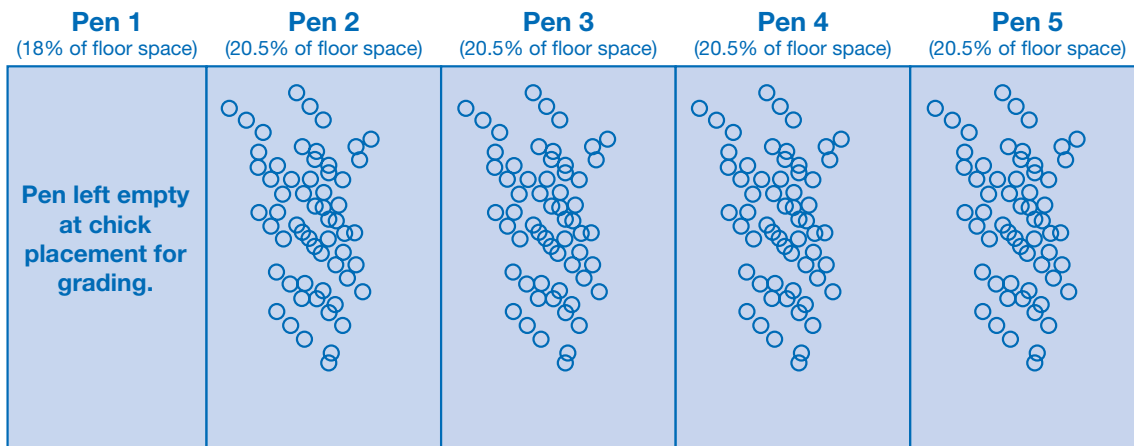

From each pen/population a random sample of birds should be caught and weighed. All birds caught in the catching pen need to be weighed to avoid selective weighing, but as a minimum, the weights of 2% of the pen/population or 50 birds (whichever is the greater), need to be recorded. In this example, a total of 197 birds have been weighed.

The print-out produced from the electronic weigh scales can be used to establish the cut-off points for grading (Figure 34).

Figure 34: Example of a print-out from an electronic scale for a 3-way grade with adjustable penning (Ross 308 flock).

CURRENT DATA METRIC	
TOTAL WEIGHED:	197
AVERAGE WEIGHT:	0.446
DEVIATION:	0.06
C.V. (%) :	13.5

Band limits	Total
0.320 to 0.339	4
0.340 to 0.359	10
0.360 to 0.379	13
0.380 to 0.399	14
0.400 to 0.419	16
0.420 to 0.439	15
0.440 to 0.459	25
0.460 to 0.479	27
0.480 to 0.499	26
0.500 to 0.519	19
0.520 to 0.539	11
0.540 to 0.559	10
0.560 to 0.579	7

Flock details	kg	lbs
Age	28	28
Target weight	0.450	0.99
Average weight	0.446	0.98
Total birds weighed	197	197

Based on this flock sampling data, a 3-way grade is required as detailed below; i.e. flock CV% is above 12%

Flock Uniformity	Percentage in each population after grading			
	CV%	2 or 3 way grade	Light %	Normal %
10	2 or 3 way grade	20	≈ 80 (78-82)	0
12	3 way grade	22-25	≈ 70 (66-73)	5-9
14	3 way grade	28-30	≈ 58 (55-60)	12-15

CURRENT DATA IMPERIAL	
TOTAL WEIGHED:	197
AVERAGE WEIGHT:	0.98
DEVIATION:	0.13
C.V. (%) :	13.5

Band limits	Total
0.705 to 0.747	4
0.750 to 0.791	10
0.794 to 0.836	13
0.838 to 0.880	14
0.882 to 0.924	16
0.926 to 0.968	15
0.970 to 1.012	25
1.014 to 1.056	27
1.058 to 1.100	26
1.102 to 1.144	19
1.146 to 1.188	11
1.190 to 1.232	10
1.235 to 1.276	7

Cut off points and number of birds in each group:

	% of birds	No. of birds
Light Birds	29	57
Normal Birds	57	112
Heavy Birds	14	28

From the information recorded on the print-out the CV% of the flock has been calculated as 13.5.

$$CV\% = \frac{\text{Standard Deviation}}{\text{Average Body Weight}} \times 100$$

The CV% is above 12 so a 3-way grade is required and the flock needs to be split into 3 populations; light, normal and heavy weight birds. The percentage of birds required in each of the 3 populations is approximately 29% light birds, 57% normal and 14% heavy birds (**Table 7**).

To determine the cut-off point for the lightest birds (i.e. the weight below which birds are considered to be light) the following steps need to be taken

1. The light population will be approximately 29% of the entire flock. Twenty-nine percent of the total number of birds weighed is 57 (29% of 197).
2. The lightest 57 birds are in the weight range of 320 to 419 g (0.71 to 0.92 lbs), colored orange in **Figure 34**.
3. A 'light' bird will therefore be anything less than or equal to 419 g (0.92 lbs) in weight.

This calculation needs to be repeated for normal and heavy birds. **Table 8** gives the cut off weights for each of the 3 populations (light, normal and heavy) based on the print-out given in **Figure 34**.

Table 8: Determination of cut-off weights for a 3-way grade based on the information given in **Figure 34**.

Category	% of Birds to be Included in Grading Category	Number of Birds for Determining Cut-off Weight (% x 197)	Weight Range g (lbs)	Chart Reference Color
Light	29	57	320 - 419 (0.71 - 0.92)	Orange
Normal	57	112	420 - 519 (0.93 - 1.14)	Blue
Heavy	14	28	520 - 579 (1.15 - 1.28)	Green

After the cut-off weights for each graded population have been determined, all birds in the flock should be weighed again and the light (any bird 419 g [0.92 lbs] in weight or below) and heavy birds (any bird 520 g [1.15 lbs] in weight or above) removed and graded into another pen. As there is now significant variation in the size of each graded population (29% are light, 57% are normal and 14% are heavy), pen sizes will need to be adjusted to accommodate the new population numbers and equalize stocking density, and feeder and drinker space (**Figure 35**).

Figure 35: Graded plan based on the body weight results given in **Figure 34** (3-way grade with adjustable penning).

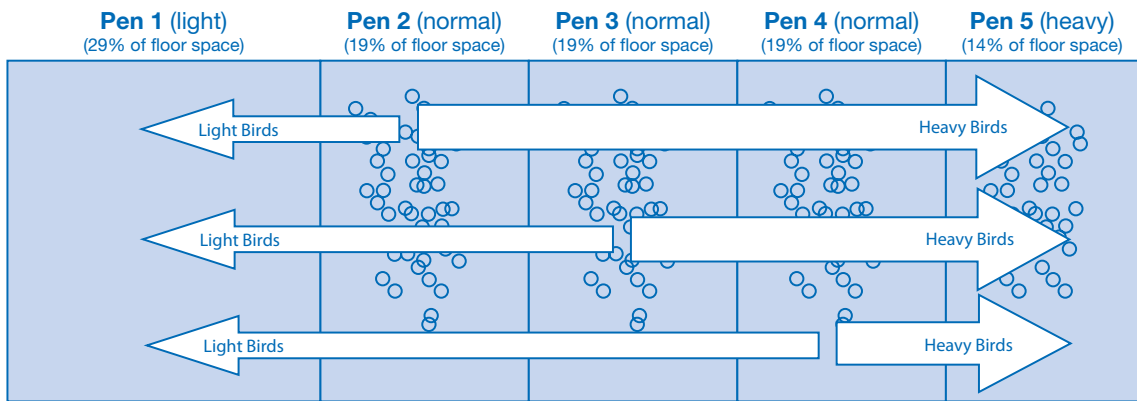

After grading, a sample of birds should be reweighed from each population (a minimum of 2% or 50 birds which ever is greater) and the average weight, CV% and number of birds for each pen established (**Figure 36**). The CV% for the graded populations will have been improved, but the overall flock CV% remains the same (**Figure 36**).

Figure 36: Situation after a 3-way grade (adjustable penning).

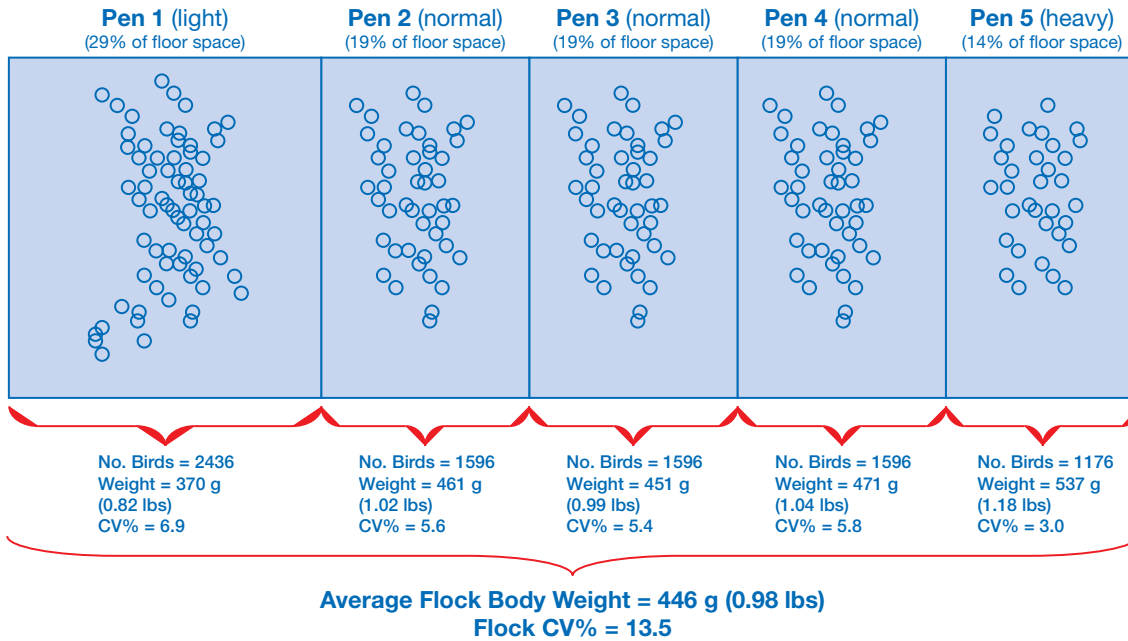

The 'normal' pens should be similar in weight and can be treated as one population. However, the farm manager should be aware of the average weight of each individual pen and any sudden deviations from the planned target should be investigated

The body weights from the graded populations should be plotted against target on a body weight target chart and the profile re-drawn where necessary to bring birds back onto target by 63 days (9 weeks) of age. Any adjustment in feed levels should be based on the deviation from target body weight. Refer to the section on Flock Management after Grading for more information.

Note, after grading the light population may not need to receive an immediate increase in feed. Body weight will increase due to the reduced competition from the larger birds and so an initial increase in feed is not required.

Grading when adjustable penning is not available (i.e fixed penning)

In some situations penning arrangements cannot be adjusted or altered (i.e. the pen sizes are fixed). The examples below describe the best-fit management practice to suite this situation.

Two-way grade with fixed pens - pre-grade CV% below 12

Figure 37 represents a house where the penning set up is fixed. The house is split into 4 pens, each of the same size. The pre-grading population has been split between 3 pens, and one pen has been left empty, from placement, for the purpose of grading. The flock consists of 8,400 birds and each of the 3 populated pens contains 2,800 birds.

Figure 37: Typical fixed pen set-up for 2-way grading.

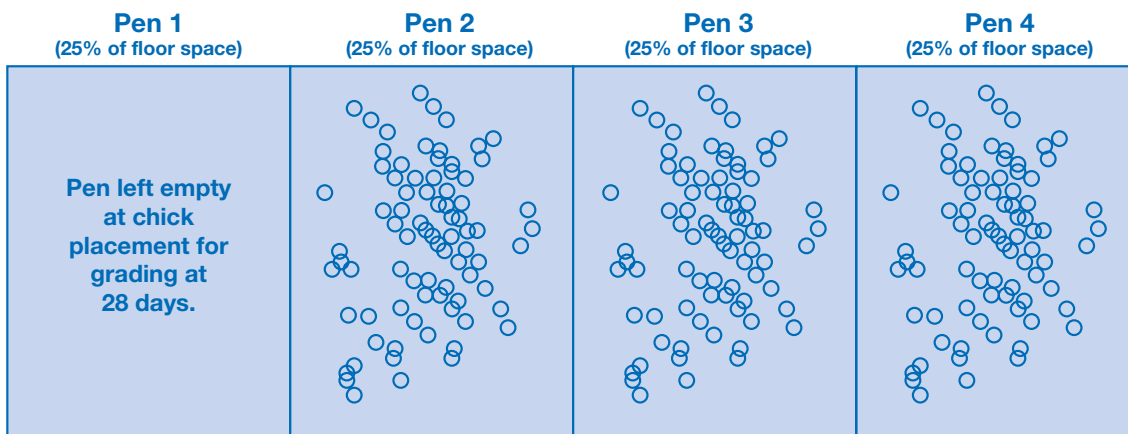

A random sample of birds must be weighed from each population. All birds caught in the catching pen must be weighed to avoid selective bias but as a minimum the weights of 2% of the population or 50 birds (whichever is greater) should be recorded per population. In this example, a total of 95 birds have been weighed. The print-out produced from the electronic weigh scales can be used to establish the cut-off points for grading (Figure 38).

Figure 38: Example of a print-out from an electronic scale for a 2-way grading with fixed penning (Ross 708 flock).

CURRENT DATA METRIC	
TOTAL WEIGHED:	95
AVERAGE WEIGHT:	0.437
DEVIATION:	0.045
C.V. (%):	10.3

Band limits	Total
0.340 to 0.359	5
0.360 to 0.379	7
0.380 to 0.399	12
0.400 to 0.419	11
0.420 to 0.439	13
0.440 to 0.459	16
0.460 to 0.479	10
0.480 to 0.499	9
0.500 to 0.519	6
0.520 to 0.539	4
0.540 to 0.559	2

Flock details	kg	lbs
Age	28	28
Target weight	0.400	0.88
Average weight	0.437	0.96
Total birds weighed	95	95

Based on this flock sampling data a two way grade is required as detailed below; i.e. flock CV% is below 12%.

Flock Uniformity	Percentage in each population after grading			
	CV%	2 or 3 way grade	Light %	Normal %
10	2 way grade	20	~ 80 (78-82)	0
12	3 way grade	22-25	~ 70 (66-73)	5-9
14	3 way grade	28-30	~ 58 (55-60)	12-15

CURRENT DATA IMPERIAL	
TOTAL WEIGHED:	95
AVERAGE WEIGHT:	0.96
DEVIATION:	0.099
C.V. (%):	10.3

Band limits	Total
0.750 to 0.791	5
0.794 to 0.836	7
0.838 to 0.880	12
0.882 to 0.924	11
0.926 to 0.968	13
0.970 to 1.012	16
1.014 to 1.056	10
1.058 to 1.100	9
1.102 to 1.144	6
1.146 to 1.188	4
1.190 to 1.232	2

Cut off points and number of birds in each group:

	% of birds	No. of birds
Light Birds	25	24
Normal Birds	75	71

From the print-out the CV% has been calculated as 10.3.

$$CV\% = \frac{\text{Standard Deviation}}{\text{Average Body Weight}} \times 100$$

This flock has a CV% below 12 and requires a 2-way grade; the flock should be split into 2 separate populations (light and normal weight birds). In a system which has adjustable penning the percentage of birds in each grading category would be 20% light, 80% normal. However, in a fixed penning system each graded population will need to be split evenly across the available pens which are of equal size. In this example, there are 4 pens each of the same size, 25% of the population will need to be housed in each pen; the percentage of birds in each graded population will therefore be 25% light and 75% normal.

To determine the cut-off point for the lightest birds (the weight below which birds are considered to be light) the following steps need to be taken:

1. The light population will be approximately 25% of the entire flock. Twenty-five percent of the total number of birds weighed is 24 (25% of 95).
2. The lightest 24 birds are in the weight range of 340 to 399 g (0.75 - 0.86 lbs), colored orange in **Figure 38**.
3. A 'light' bird will therefore be anything less than or equal to 399 g (0.86 lbs) in weight.
4. A 'normal' bird will be one that is 400 g (0.86 lbs) in weight or above, shaded in blue in **Figure 38**.

After the cut-off weights for each graded population has been determined, all birds in the flock should be weighed again and the light birds removed (any bird 399 g [0.86 lbs] in weight or below) and graded into the empty pen (**Figure 39**).

Figure 39: Graded plan based on the results from the print-out given in **Figure 38** (2-way grade with fixed penning).

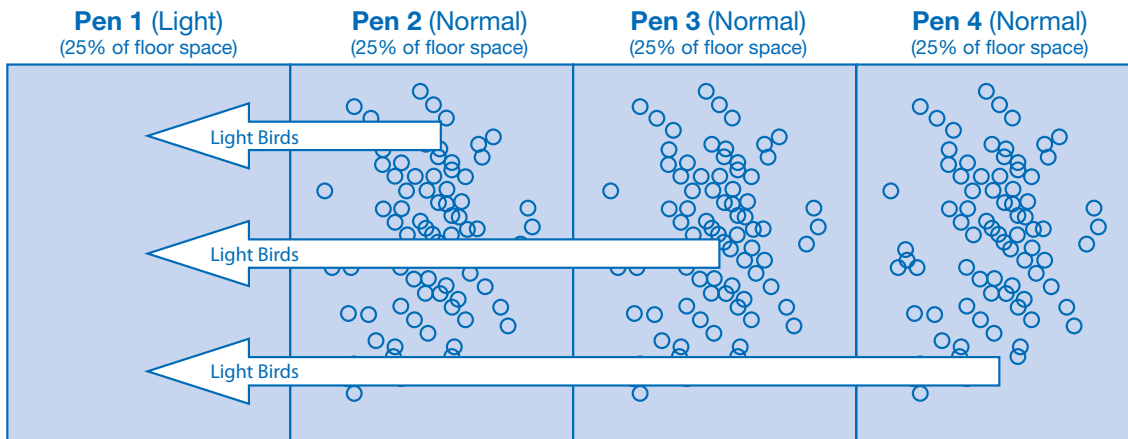

After grading, a sample of birds should be reweighed from each population (a minimum of 2% or 50 birds which ever is greater) and the average weight, CV% and number of birds for each pen established (**Figure 40**). The CV% for the graded populations will have been improved, but the overall flock CV% remains the same (**Figure 40**).

Figure 40: Situation after grading; 2-way grade fixed penning.

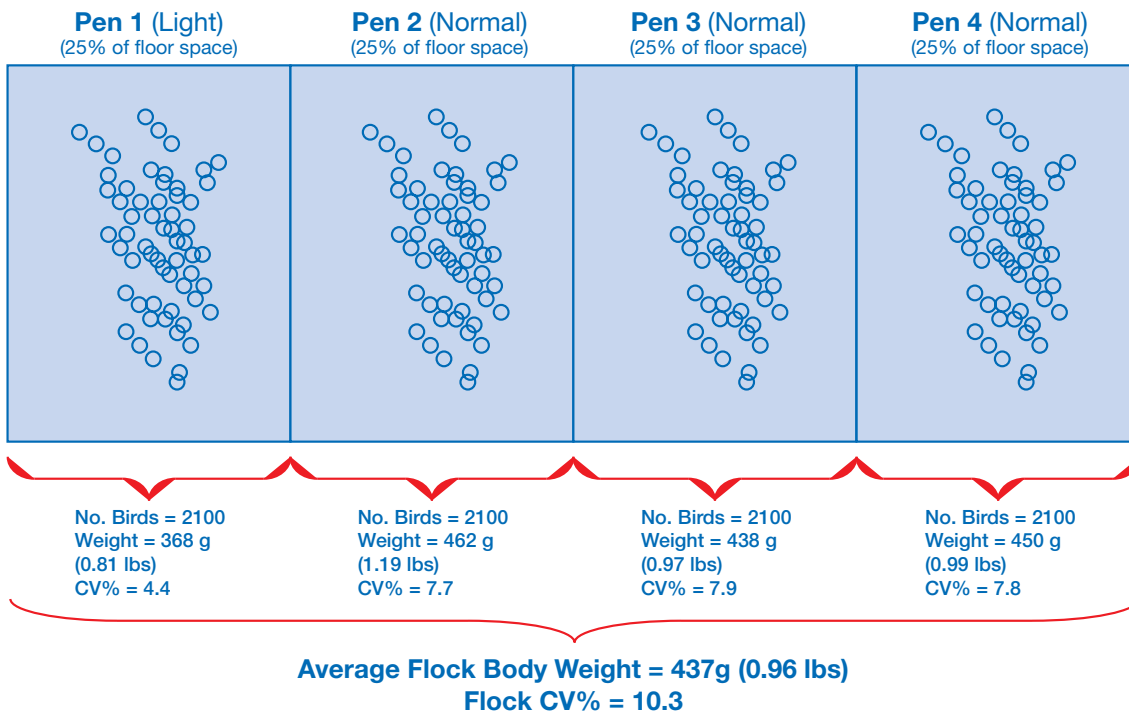

The 'normal' pens should be similar in weight and can be treated as one population. However, the farm manager should be aware of the average weight of each individual pen and any sudden deviations from the planned target should be investigated

The body weights from the graded populations should be plotted on a body weight target chart against target and the profile re-drawn to bring birds back onto target by 63 days (9 weeks) of age. Any adjustment in feed levels should be based on the deviation from target body weight. Refer to the section on Flock Management after Grading for more information.

Note that after grading, the light population may not need to receive an immediate increase in feed. Body weight will increase due to the reduced competition from the larger birds and so an initial increase in feed is not required.

Three-way grade with fixed pens - pre-grade CV% above 12

The example below shows the process that needs to be followed for a 3-way grade when fixed penning is in place. The initial pen set-up is 4 pens each of equal size, one of which has been left empty for the purposes of grading (Figure 41). The flock size is 8,400 birds, and in each of the 3 populated pens there are 2,800 birds.

Figure 41: Typical fixed pen set up for 3-way grading.

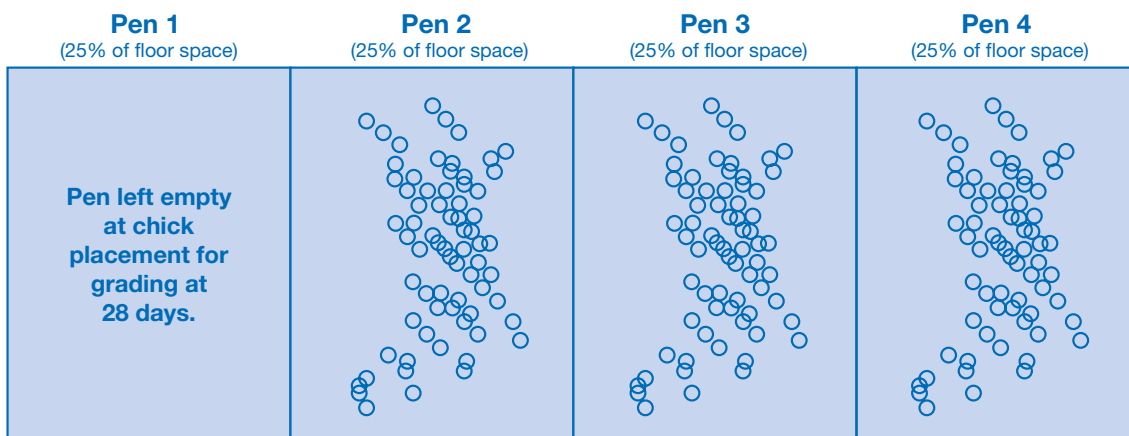

A random sample of birds must be weighed from each population. All birds caught in the catching pen must be weighed to avoid selective bias, but as a minimum, the weights of 2% of the population or 50 birds (whichever is greater) should be recorded per population. In this example, a total of 197 birds have been weighed. The print-out produced from the electronic weigh scales can be used to establish the cut-off points for grading (Figure 42).

Figure 42: Example of a print-out from an electronic scale for a 3-way grade with fixed penning (Ross 708 flock).

CURRENT DATA METRIC	
TOTAL WEIGHED:	197
AVERAGE WEIGHT:	0.449
DEVIATION:	0.058
C.V. (%):	13.0

Band limits	Total
0.320 to 0.339	4
0.340 to 0.359	8
0.360 to 0.379	11
0.380 to 0.399	12
0.400 to 0.419	14
0.420 to 0.439	17
0.440 to 0.459	27
0.460 to 0.479	29
0.480 to 0.499	26
0.500 to 0.519	20
0.520 to 0.539	12
0.540 to 0.559	10
0.560 to 0.579	7

Flock details	kg	lbs
Age	28	28
Target weight	0.400	0.88
Average weight	0.449	0.99
Total birds weighed	197	197

Based on this flock sampling data a 3-way grade is required as detailed below; i.e. flock CV% is above 12%.

Flock Uniformity	Percentage in each population after grading			
	CV%	2 or 3 way grade	Light %	Normal %
10	2 way grade	20	≈ 80 (78-82)	0
12	3 way grade	22-25	≈ 70 (66-73)	5-9
14	3 way grade	28-30	≈ 58 (55-60)	12-15

CURRENT DATA IMPERIAL	
TOTAL WEIGHED:	197
AVERAGE WEIGHT:	0.99
DEVIATION:	0.13
C.V. (%):	13.0

Band limits	Total
0.705 to 0.747	4
0.750 to 0.791	10
0.794 to 0.836	13
0.838 to 0.880	14
0.882 to 0.924	16
0.926 to 0.968	15
0.970 to 1.012	25
1.014 to 1.056	27
1.058 to 1.100	26
1.102 to 1.144	19
0.146 to 1.188	11
1.190 to 1.232	10
1.235 to 1.276	7

Cut off points and number of birds in each group:

	% of birds	No. of birds
Light Birds	25	49
Normal Birds	50	99
Heavy Birds	25	49

From the print-out, the CV% for the total population has been calculated as 13.0.

$$CV\% = \frac{\text{Standard Deviation}}{\text{Average Body Weight}} \times 100$$

This flock has a CV% of greater than 12% so a 3-way grade is required. The flock needs to be split in to 3 populations, light, normal and heavy weight birds. In a system that has adjustable penning, the percentage of birds in each grading category would be 29% light, 57% normal and 14% heavy birds (**Table 7**). However, in a fixed penning system each graded population will need to be split evenly across the pens as all pens are of the same fixed size. So in this example 25% of the population will need to be housed in each pen; the percentage of birds in each population will therefore be 25% light, 50% normal and 25% heavy.

To determine the cut-off point for the lightest birds (the weight below which birds are considered to be light) the following steps should be taken:

1. The light population will be approximately 25% of the entire flock. Twenty-five percent of the total number of birds weighed is 49 (25% of 197).
2. The lightest 49 birds are in the weight range of 320 to 419 g (0.71 – 0.92 lbs), colored orange in **Figure 42**.
3. A ‘light’ bird will therefore be anything less than or equal to 419 g in weight (0.92 lbs).

This calculation needs to be repeated for normal and heavy birds. The cut-off weights for the 3 graded populations based on the print-out in **Figure 42** are given in **Table 9**.

Table 9: Determination of cut-off weights for a 3-way grade based on the information given in **Figure 42**.

Category	% of Birds to be Included in Grading Category	Number of Birds for Determining Cut-off Weight (% x 197)	Weight Range g (lbs)	Chart Reference Color
Light	25	49	320 - 419 (0.71 - 0.92)	Orange
Normal	50	99	420 - 499 (0.93 - 1.10)	Blue
Heavy	25	49	500 - 579 (1.10 – 1.28)	Green

After the cut-off weights for each graded population has been determined, all birds in the flock should be weighed again and the light and heavy birds graded in to separate pens (**Figure 43**).

Figure 43: Graded plan based on the results from the print-out given in **Figure 42** (3-way grade with fixed penning).

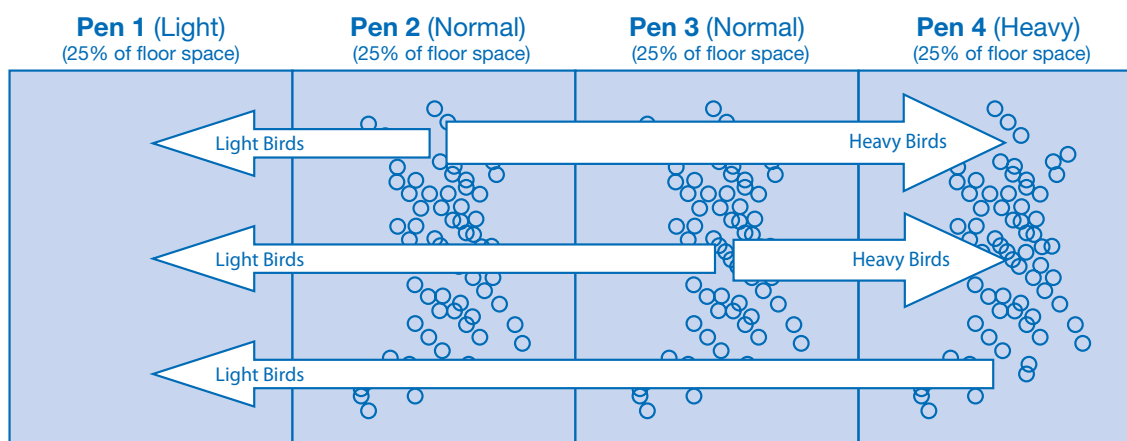

After grading, bird numbers, average weight, and CV% of each pen should be re-calculated. The CV% for the graded populations will have been improved, but the overall flock CV% remains the same (**Figure 44**).

The ‘normal’ pens should be similar in weight and can be treated as one population. However, the farm manager should be aware of the weight of each individual pen and any sudden deviations from the planned target should be investigated.

The body weights from the graded populations should be plotted against target on a body-weight target chart and the profile re-drawn where necessary to bring birds back onto target by 63 days (9 weeks) of age. Any adjustment in feed levels should be based on the deviation from target body weight. Refer to the section on Flock Management after Grading for more information.

Note that after grading, the light population may not need to receive an immediate increase in feed. Body weight will increase due to the reduced competition from the larger birds and so an initial increase in feed is not required.

Figure 44: Situation after a 3-way grade (fixed penning).

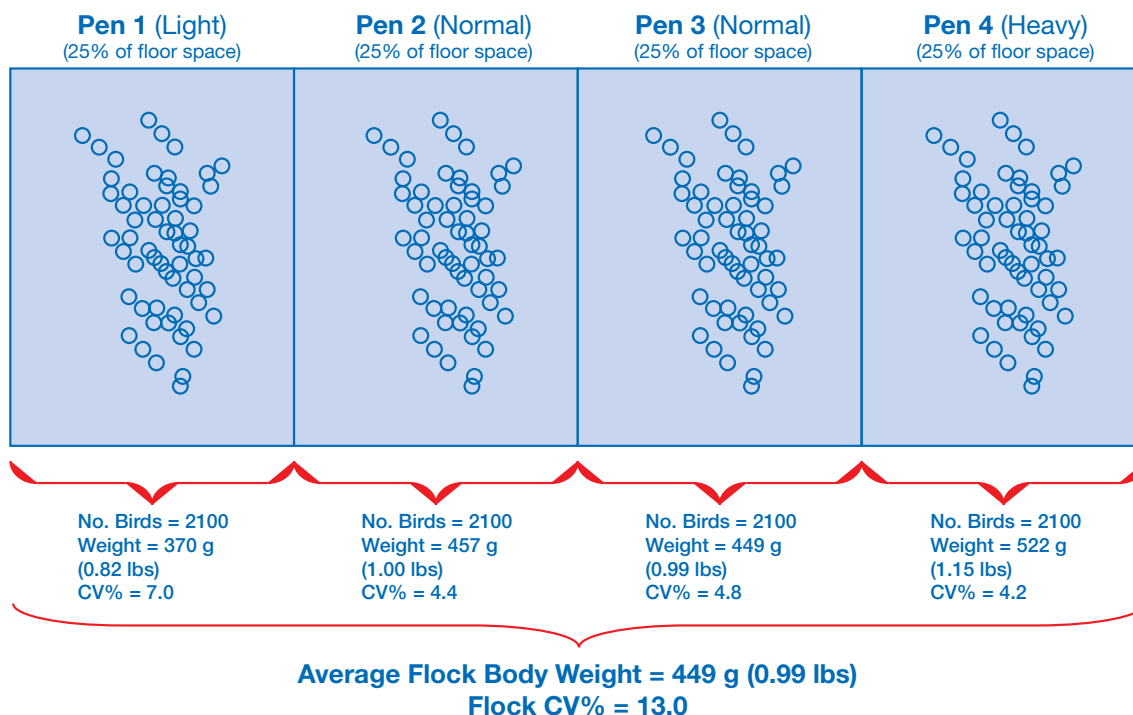

KEY POINTS

- Grade males and females at 28 days (4 weeks).
- A successful grading will reduce the CV% to below 8 in all of the graded populations.
- Each population should be reweighed and counted to confirm the average body weight and uniformity so projected target body weights and feeding rates can be determined.
- Inaccurate counting of birds after grading may lead to incorrect feed quantities being given.
- Each population is best served by its own dedicated feeding system. Where this cannot be provided, supplementary feeding must allow even distribution of feed and adequate feeding space per bird.
- If population sizes in lay are likely to be larger than they were in rear, birds will have to be mixed at transfer. Here it is especially important that management after grading results in the birds converging to a common target body weight by the expected age of transfer.
- Ensure that stocking density, drinking and feeding space are consistent with the recommended guidelines after grading, this is especially important where pen size is adjusted during grading.
- It is recommended to use automatic rather than manual weigh scales.

Flock Management after Grading (Post 28 Days)

After grading, the flock must be managed so that graded populations achieve target weight in a uniform and co-ordinated manner.

Post-grading body-weight management (up to 63 days of age)

At grading, the flock will have been divided into 2 or 3 populations, depending on the original CV%. For each graded population, the aim is to achieve the target body weight uniformly within the period during which skeletal development is taking place (i.e. before 63 days of age). After 28 days of age the weekly body weights of each population must continue to be monitored and feed allocations adjusted as necessary to allow the required body-weight targets to be met.

Under target weight birds (light population)

Where the average body weight after grading for a population/pen is below target body weight by more than 100 g (0.22 lbs) (if target is 450 g [0.99 lbs], birds below 350 g [0.77 lbs]), the objective is to achieve target body weight by 63 days (**Figure 45**). The body-weight curve should be re-drawn so that birds are brought gradually back onto target by 63 days (9 weeks). For the first week after grading, the 'light' population should be held on the same feeding volume as that prior to grading (i.e. do not increase feed levels). Body weight will be increased due to the reduced competition from the larger birds. Subsequent appropriate increases in feed should then be based on the deviation from target body weight.

On target weight category birds (normal population)

The aim is to continue to keep birds on target (**Figure 45**).

Over target weight category birds (heavy population)

These are birds that are greater than 100 g (0.22 lbs) over the target body weight, (if target is 450 g [0.99 lbs], birds above 550 g [1.21 lbs]). Here the body-weight curve should be re-drawn so that birds are gradually brought back onto target by 63 days (**Figure 45**). Feed levels should never be reduced but it may be necessary to reduce the next feed increment or delay the next feed increase in order to achieve the revised body-weight profile.

Figure 45: Re-drawing of future body-weight targets up to 63 days (9 weeks) of age.

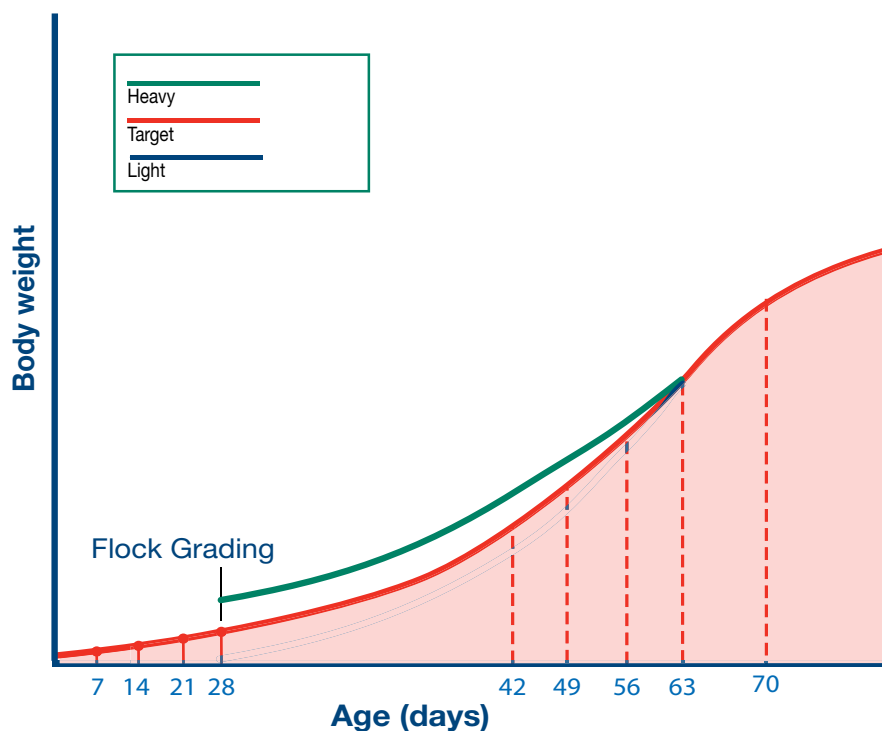

Post 63 days re-drawing of future body-weight profiles

At 63 days of age the weight of the population in relation to the target should be re-assessed. Populations that are of similar weight and feed consumption can be combined at this age.

Under target weight birds (light population)

If birds remain under target at 63 days (9 weeks) the target should be re-drawn so that birds are brought back onto target profile gradually (**Figure 46**), achieving body weight by 105 days. Feed levels should be increased or the next feed increase brought forward to achieve this.

Figure 46: Re-drawing of future body-weight targets when average body weight is below, on, or above target at 63 days (9 weeks) of age.

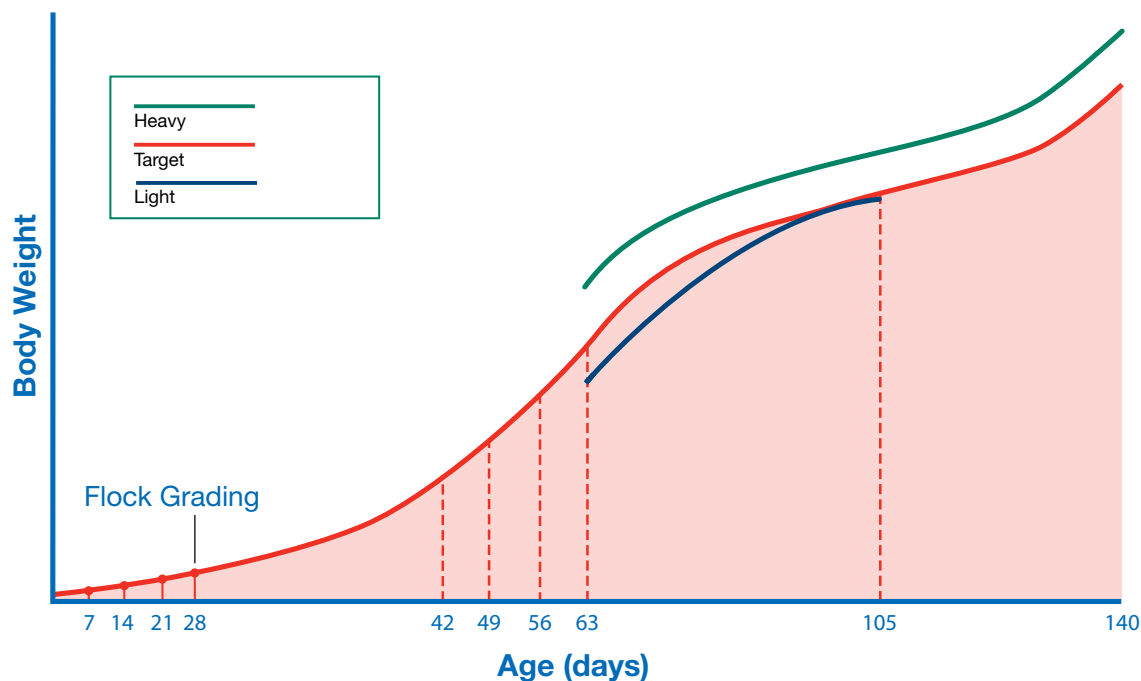

On target weight birds (normal population)

The aim is to continue to keep birds on target (**Figure 46**).

Over target weight birds (heavy population)

If birds remain overweight at 63 days (9 weeks of age) the target should be re-drawn parallel to the curve (**Figure 46**). Attempting to bring birds back to target at this stage will reduce peak rate of lay. Birds should be fed the level of feed required to achieve the revised target profile.

However, it is important to note that females that remain over target weight from this stage are likely to have an earlier onset of sexual maturity. This may cause problems when mating with males that are on target body-weight, due to lack of synchronization of maturity between males and females.

At this point individual populations are being grown to different set profiles (for example, overweight populations will remain overweight from this point onwards) so it is not advised to transfer birds between populations at this stage.

KEY POINTS

- Continue weekly body weight monitoring.
- Stop bird movements from pen to pen from 63 days.
- From 63 days re-draw the target weights of any population that is below target body weight to bring them back on target by 105 days of age.
- If the birds are overweight at 63 days re-draw the target profile line above and parallel to the standard. Do not attempt to bring birds that are overweight back to target, this will delay sexual maturity and reduce peak production.
- Care should be taken before mixing any pens to ensure body weight and feed consumption per bird is similar.

Alleviation of body weight problems

If the average body weight differs from target body weight by +/-100 g (0.22 lb), or more, during rear reweigh a sample of birds. If the weights are correct, consider the following:

Underweight prior to 105 days, consider the following in future flocks

- Remain on starter feed for longer.
- Feed a higher nutrient quality starter.
- A longer daylength can be provided until 21 days (3 weeks) of age to help stimulate feed intake and improve body-weight gain.

Underweight prior to 105 days, consider the following in current flocks

- Initiate the next feed increase earlier and consider increasing the amount if necessary, until body weight is brought gradually back to target.
- See **Figures 45** and **46** for examples of such corrective action.

Overweight prior to 105 days

- Do not reduce feed lower than the current feeding level.
- Reduce the next feed increment, e.g. 2 g (0.07 oz) per birds instead of 4 g (0.14 oz) per bird.
- Delay the next feed increase.
- Check to see if the energy level of the diet is higher than expected.
- See **Figures 45** and **46** for examples of such corrective action.

Section 2 - Management into Lay (15 Weeks to Peak Production)

From 105 Days (15 Weeks) to Light Stimulation

Objective

To minimize variation in the onset of sexual maturity of the flock and to prepare the flock for the physiological demands of early reproduction.

Principles

Correct body weight gains during this period will ensure a smooth and uniform transition to sexual maturity and egg production in the females, and will support uniform and optimum physical condition and fertility in males.

Management Considerations

Achieving the correct stocking density, feeder and drinker space as birds reach sexual maturity is key to preventing a loss of uniformity within the flock, reducing variation in sexual maturity (both within and between males and females), and helping to maintain optimum physical condition and reproductive fitness of the flock. After 140 days (20 weeks) of age stocking density needs to be reduced, and feeder and drinker space increased, to account for increased bird size and additional equipment (such as nest boxes) in the house during lay.

Stocking density

Stocking density affects biological output. Recommended stocking densities for male and females from 15 weeks of age to depletion for both males and females are given below (**Table 10**). The figures given are a guide, actual stocking densities may vary from those recommended depending on:

- Welfare regulations.
- Economics.
- Environment.
- Actual available floor space, drinker and feeder space.

Environment (ventilation) and management conditions (feeder and drinker space) must be appropriate for stocking density to prevent adverse effect on performance from occurring.

Table 10: Recommended stocking densities from 15 weeks of age to depletion.

	Stocking Density Birds/m ² (ft ² /bird)	Stocking Density Birds/m ² (ft ² /bird)
	15-20 weeks	20 weeks to depletion
Male	3-4 (2.7-3.6)	3.5-5.5 (2.0-3.1)
Female	4-7 (1.5-2.7)	

Feeder and drinker space

Recommended feeder and drinker spaces for both males and females are given in **Table 11**.

Table 11: Recommended feeder and drinker space from 15 weeks of age to depletion.

	Age	Feeder		Drinker		
		Track cm (in)	Pan cm (in)	Bell cm (in)	Nipple	Cups
Male	15-20 weeks	15 (6)	11 (4)	1.5 (0.6)	8-12 birds per nipple	20-30 birds per cup
	20 weeks to depletion	20 (8)	13 (5)	2.5 (1.0)	6-10 birds per nipple	15-20 birds per cup
Female	15-20 weeks	15 (6)	10 (4)	1.5 (0.6)	8-12 birds per nipple	20-30 birds per cup
	20 weeks to depletion	15 (6)	10 (4)	2.5 (1.0)	6-10 birds per nipple	15-20 birds per cup

KEY POINTS

- Follow recommended allowances for stocking density, and for feeder and drinker spaces.
- Ensure increases in available floor space, and feeding and drinking spaces are given at the recommended ages.

Target weight

Management focus during the period from 15 weeks (105 days) of age to light stimulation is the same for both males and females. The aim is to maintain a uniform flock of birds which are on the target body-weight profile so that the transition to sexual maturity occurs uniformly and at the desired age. This is done by following the recommended increases in weekly energy intake and body weight.

Regular monitoring and recording of body weight and uniformity are vital management tools during this period. Development of secondary sexual characteristics such as increased pin bone spacing in females and increased facial color in both sexes are good indicators of flock progress in sexual development.

Failure to meet required weekly incremental gains in body weight between 15 weeks of age and light stimulation is a common cause of poor performance, leading to:

- Delayed onset of lay.
- Poor initial egg size.
- Increased percentage of rejected and misshapen eggs.
- Increased number of infertile eggs.
- Increased broodiness.
- Loss of uniformity of body weight and sexual maturity.
- Reduced peak production.
- Loss of sexual synchronization between males and females.

Where average body weight is **under** target (defined as body weight being more than 100 g [0.22 lbs] below target weight) at 105 days (15 weeks) of age, the body-weight curve should be re-drawn and the birds gradually brought back onto target body weight (by giving appropriate increases in feed) by the time of light stimulation (**Figure 47**).

Flocks which are over-fed and exceed target body weights between 15 weeks of age and light stimulation will commonly exhibit:

- Early onset of lay.
- Increased incidence of double yolks.
- Reduced hatching egg yield.
- Increased feed requirement through lay.
- Reduced peak, persistency and total eggs.
- Reduced male and female fertility throughout life.
- Increased incidence of peritonitis and prolapse.
- Loss of sexual synchronization between males and females.

Where average body weight is **over** target (100 g [0.22 lbs] or more above target weight) at 105 days (15 weeks) the body-weight curve should be redrawn parallel to target (**Figure 47**). Note that birds must not be brought back to target if they are overweight; this will result in a loss of condition which will have a negative impact on egg production.

Once birds are overweight, it is a matter of managing for damage limitation (minimize the negative effect on production and uniformity). For underweight birds, it is possible to improve the situation by increasing feed levels and weight gain. Ideally, neither situation should occur and close monitoring is central to effective management.

Figure 47: Redrawing of body-weight profiles if females are under (light) or over (heavy) target weight at 15 weeks (105 days) of age.

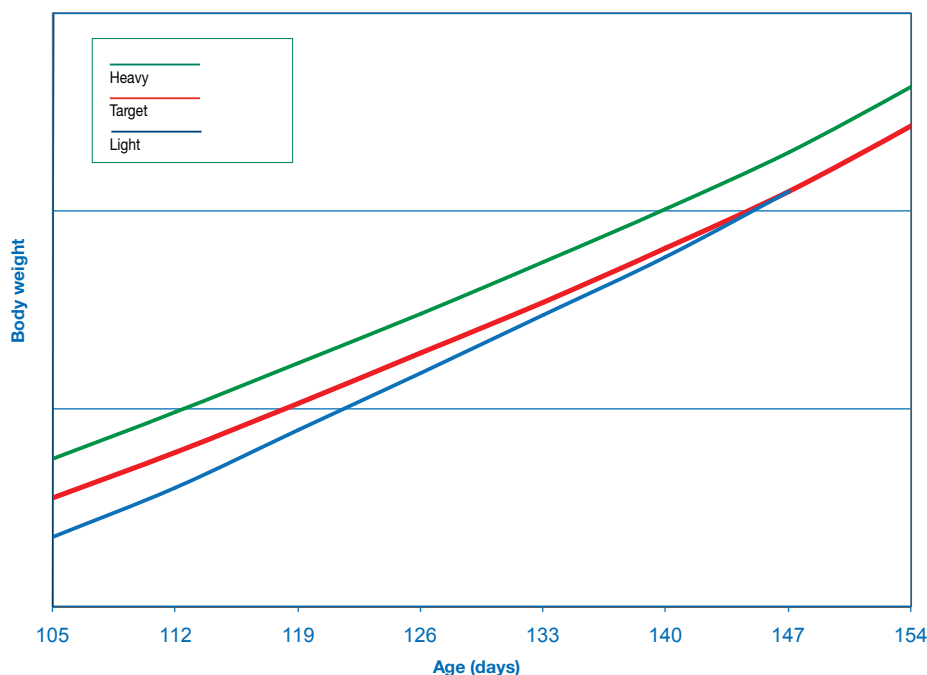

KEY POINTS

- Ensure flock body weight follows the target profile.
- Maximize uniformity of body weight and sexual maturity.
- Redraw target body weight if necessary if the flock is under- or overweight at 15 weeks (105 days); grow birds that are underweight to regain target by light stimulation, for overweight birds set a new target.

Feed type and energy level

Inadequate nutrient supply as birds reach sexual maturity is a frequent cause of loss of uniformity. Careful management is required when feed type is changed (e.g. from grower to pre-breeder) and the farm manager should be aware of any changes in energy content between feed types or formulas. When a change in feed type occurs, feed provision must be altered accordingly; if energy content of the feed is reduced with a change in feed type, feed provision will need to be increased and vice versa.

KEY POINT

- Be aware of any changes in energy content between feed type and formulas and alter feed provision accordingly to account for this.

Lighting

In the period from 15 weeks of age to light stimulation, it is important that a constant 8 hours of light is maintained so that birds can respond appropriately to the light stimulation when it occurs (see section on Lighting).

KEY POINT

- Follow recommended lighting programs.

Rear and move facilities

It is common practice to move birds from rearing facilities to separate laying facilities. Age at which transfer to the laying facilities occurs can vary depending on housing type. For light proof laying facilities, transfer should not occur later than 21 weeks (147 days) of age. For open-sided laying facilities, transfer may need to be later than 21 weeks (depending on season and natural daylength). Regardless of what type of housing is used, transfer should not be completed before 18 weeks (126 days) or after 23 weeks (161 days) of age. It is recommended that males are moved before the females (at least one day before) to allow them to find the feeders and drinkers.

An additional increase in feed quantity (approximately 50% more) on the day before and the day of transfer will help compensate for moving stress. Birds should not be fed on the morning they are due to be moved. Feeders in the laying facility should be fully charged so that birds have immediate access to feed on arrival. Feed levels should be returned to normal on the first or possibly second day after transfer. The exact amount of extra feed given and the length of time over which it is given after transfer will depend on season, environmental temperature, and transport duration.

It is important that feeding space is not reduced and that lighting programs and biosecurity are synchronized between rearing and laying houses.

After transfer, check crop fill of both males and females (**Figure 48**) to ensure they are finding feed and water. Crop fill should be assessed on the day of transfer, 30 minutes after the first feed and then again 24 hours later. A random sample of at least 50 females and 50 males should be assessed. If crop fill is found to be inadequate (ideally all birds assessed should have a full crop) the reason for this should be investigated and resolved (possibilities include; inadequate feeder space, feed distribution or availability of feed).

Figure 48: Crop fill assessment of broiler breeders after transfer. The bird on the left has an empty crop and the bird on the right a full crop.



KEY POINTS

- Provide extra feed on the day before and the day of transfer.
- Ensure that males and females are finding feed and water after transfer by monitoring feeding behavior and checking crop fill.

Day-old to depletion facilities

In day-old to depletion facilities where the feeding system is changed between rear and lay, transferring birds to the new feeding system must be managed carefully. New feeders must be introduced so that birds are able to access them and find feed easily. For example, where birds are floor fed in rear and then transferred to track feeders in lay, the track feeders should initially be set at a low height (low enough to allow the birds to see feed within the feeder) for the first 1-2 days. Check crop fill to determine that all birds have found the new feeders and are managing to access feed.

KEY POINT

- Where there is a change in feeding system between rear and lay, manage this transfer carefully by ensuring that birds can easily find and get access to the new feeders.

Mixing males and females

At the time of mixing males and females, additional management techniques are needed. Attention must be paid to mating-up procedure, identification of sexing errors, management of separate-sex feeding and male: female ratio.

Mating-up

Mating-up should be started from 21 weeks (147 days) of age. Both males and females must be sexually mature before mating-up occurs; an immature male should never be mated with a mature female. A sexually mature male will have a comb and wattles which are well-developed and red in color (**Figure 49**). A sexually mature female will also have a bright red comb and wattles (**Figure 50**). Mating-up should be postponed by 7 to 14 days if sexual maturity is delayed or the birds are to be moved from dark-out rearing to open-sided laying facilities. This will give the birds more time to become sexually mature and give better control over feeding (as males will be bigger and so the separate-sex feeding systems will work better).

Where variation exists in sexual maturity within the male population and some males are visibly immature, the more mature males should be mixed with the females first. As an example, if the planned mating ratio is 9.5 to 10% then a possible system of mating-up would be to mix half of the total number of required males (those that are most mature) at 21 weeks, a further quarter (again the most mature males) a week later, and then finally the remaining males the following week.

If males are more mature than females, then they should be introduced to the females more gradually. For example, mate-up at a ratio of 1 male for every 20 females, then gradually add more males over the next 14 to 21 days to reach the desired mating ratio.

Figure 49: An example of a mature young male with a well-developed comb and wattles that are red in color (on the left) and an immature male with an under-developed comb and wattles that are pale in color (on the right).

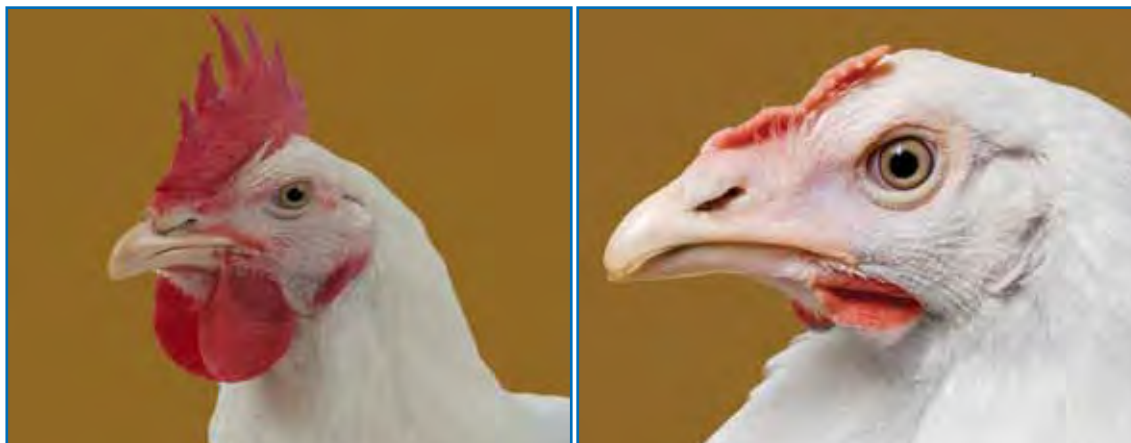
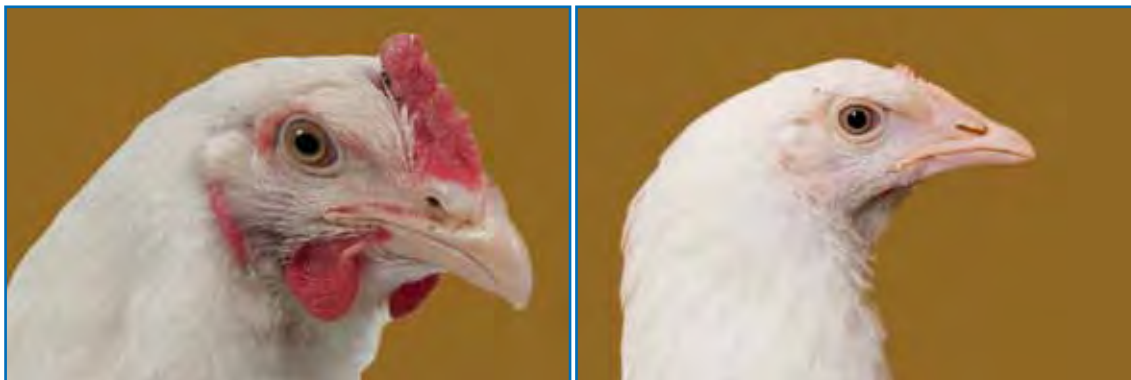

Figure 50: An example of a young female with a well-developed comb and wattles that are red in color (on the left) and an immature female with an under-developed comb and wattles (on the right).



In the period from mating-up until all males have become sufficiently large to be physically excluded from the female feeders (approximately 26 weeks of age), feeding behavior should be carefully monitored (at least twice a week). This is necessary to check that the separate-sex feeding systems are working properly and that feed is being distributed correctly and evenly around the shed.







KEY POINTS

- Ensure both males and females are sexually mature at mating-up.
- Immature males should not be mated up to mature females.
- Begin mating-up at 147 days (21 weeks).
- Monitor feeding behavior.

Sexing errors

Identifying sexing errors (males present in female pens and females present in male pens) can be difficult at early ages, but it is good practice to remove these birds whenever they are identified during the life of the flock. Ideally, all sexing errors should be removed before mating-up. The criteria for doing this are illustrated in **Figure 51**.

Figure 51: Criteria for identifying males and females for the resolution of sexing errors.

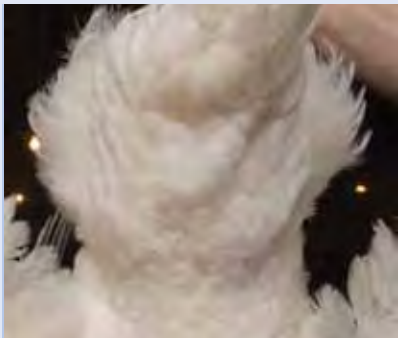
Male	Female
	
<p>Comb and Wattles 105 days (15 weeks) <i>More developed and redder in males.</i></p>	
	
<p>Hock Joints 140 days (20 weeks) <i>Thicker and broader in males. Narrower and smoother in females.</i></p>	
	
<p>Feathering Around the Neck 140 days (20 weeks) <i>Long-fringed, spear-shaped feathers in males. Denser, paddle-shaped feathers in females.</i></p>	
	
<p>Body Shape 140 days (20 weeks) <i>Males longer and narrower. Females more compact and broader around pelvis.</i></p>	

Separate-sex feeding equipment

After mating-up, males and females should be fed from separate feeding systems (**Figure 52**).

Separate-sex feeding takes advantage of differences in head size between males and females and allows more effective control of body weight and uniformity of each sex. Separate-sex feeding requires especially careful management, and feeding behavior should be monitored regularly throughout lay. At a minimum, feeding behavior should be monitored twice weekly up to 26 weeks of age. Complete exclusion of all males from the female feeders normally occurs around 26 weeks of age. Up to this point some males may still be able to access the female feeding system and steal female feed. Careful monitoring of body weight and feeding behavior is necessary at this time to ensure that both males and females are receiving enough feed to maintain target increases in body weight. After 26 weeks of age, monitoring of feeding behavior can be reduced to once a week. Feeding equipment must be properly adjusted and maintained; poorly managed and badly maintained feeding equipment gives uneven feed distribution which is a major cause of depressed egg production and fertility.

Female feeding equipment

With track feeding systems, the most effective method of preventing male access to the female feeders is to fit grills (grids or toast racks) to the tracks (**Figure 52**). Males are then excluded from the female feeders because of their greater head width and comb height, while female access remains unrestricted. Internal grill width should be 45-47 mm (1.75-1.88 in) and grill height should be 60 mm (2.36 in). The addition of horizontal wires either side of the apex of the grid will help to strengthen the grill. Grid widths less than 45 mm (1.75 in) will prevent a significant number of the females from feeding and cause reduced performance.

Figure 52: Separate-sex female feeding system showing grills (grids or toast racks).

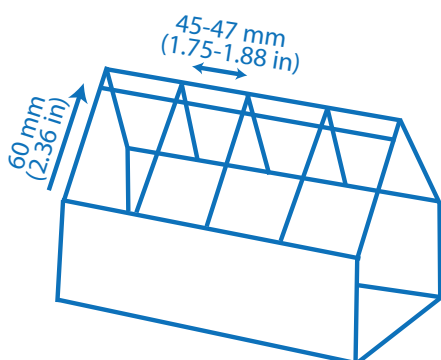

The addition of a plastic pipe in the apex of the grill can be used to further restrict male access (**Figure 53**). This is particularly useful from mating-up until physical maturity (approximately 30 weeks of age), after about 33-35 weeks of age the pipe can be removed. It is important to make sure that the piping is fixed correctly and securely to the apex of the feeder, if not it may sag and restrict female access to the feeder.

Figure 53: Separate-sex feeding system for females showing grills and the addition of plastic pipe in the apex.



An alternative to grills are roller bars (**Figure 54**). These are fitted to the track feeding system and the height is adjusted as the birds age. Bar height should start at 43 mm (1.69 in) at mating-up, and gradually be increased to 47 mm (1.88 in) by 30 weeks of age.

Figure 54: A roller bar system used to restrict male access.



A grill can also be used to prevent access by males to automatic pan feeders or hanging hoppers (tube feeders). With hanging hoppers (tube feeders), feeder movement should be reduced to a minimum.

Daily checks should be made for damage, displacement or irregularity of gaps in the female feeder system. Failure to detect and correct such problems will allow males to steal female feed (**Figure 55**), and effective control over body weight and uniformity will be lost.

Figure 55: Males stealing from female feeders.



Male feeding equipment

Three types of feeders are generally used for males (**Figure 56**):

- Automatic pan-type feeders.
- Hanging hoppers (tube feeders).
- Suspended feeder track.

Figure 56: Male feeders (from left to right; automatic pan feeders, hanging hoppers, suspended feeder track).



Hanging hoppers (tube feeders) and suspended feed tracks are both suspended from the house roof and feeder height can be adjusted appropriately for the male population. When hanging hoppers (tube feeders) are filled manually, it is important that the same feed quantity is delivered to each hopper and that the hoppers are not tilted to one side. Suspended feeder tracks for males have proved successful, because feed can be levelled or evened out within the track ensuring an even feed distribution.

After feeding, suspended feeders should be raised to deny males further access to the feeders. When feeders are raised, the next day's allocation of feed should be added so that when they are lowered at the next feeding time, males have instant access to feed. It is beneficial to delay male feeding until about 5 minutes after the female feeders have been filled.

It is essential that male feeder height is correctly adjusted so that all males have equal access to feed at the same time, while female access to the feeders is prevented (**Figure 57**). Correct male feeder height is dependent on male size and feeder design, but as a general rule, male feeder height should be in the range of 50-60 cm (20-24 in) above the litter. Care should be taken to ensure that the litter under the feeders is level and any build up of litter beneath male feeders should be avoided as this will reduce feeder height allowing females to steal male feed. Daily observation and adjustment at feeding time is necessary to ensure that male feeder height remains correct. As male numbers decline, the number of male feeders should also be reduced to ensure that feeding space remains optimal. Care should be taken to avoid giving too much feeding space to males, as the more aggressive males will over-consume, male body weight uniformity will decline, and a loss in reproductive performance will occur.

Figure 57: Correct male feeder height.



KEY POINTS

- Provide separate male and female feeding systems. Female feeding systems should have grills fitted to prevent male access and male feeders must be raised to a height that will allow only males to access them.
- Observe feeding behavior daily to ensure both sexes are feeding separately, male feeders are at the correct height, and feeding space and feed distribution are adequate.
- Daily checks should be made for damage, displacement or irregularity of gaps in the female feeder system.

Management of Females Post Light Stimulation Until 5% Production

Objective

To bring the female into lay by stimulating and supporting egg production using feed and light.

Principles

Females need to be grown to the target body-weight profile and with the recommended lighting program (see section on Lighting) so that the flock comes into production in a uniform way.

Management Considerations

For equipment, stocking density, and feeder and drinker space recommendations see **Tables 10** and **11** (15 weeks to light stimulation).

Regular feed increases (at least weekly) are essential for appropriate body-weight gain, uniform sexual maturity, fleshing, and timely onset of lay. Lighting programs should be implemented on schedule to support and stimulate females during this period. The first light increase should be given around 147 days (21 weeks) of age, but the exact timing will depend primarily on body weight and flock uniformity. If the flock is uneven (CV greater than 10%) light stimulation should be delayed by approximately one week (see section on Lighting).

Water should be freely available. The breeder layer feed should be introduced from 5% hen-day production at the latest to ensure that the birds receive the correct amount of nutrients (such as calcium) to support egg production.

Any problems with feed, water, or disease at this stage can have devastating effects on the onset of production and subsequent flock performance. It is therefore wise to monitor and record uniformity, body weight, and feed clean-up time; responding quickly to any decrease in uniformity, any change in feed clean-up time, or any reduction in body-weight gain.

Nest boxes should be opened just before the anticipated arrival of the first egg. This will likely be 10-14 days after the first light increase is given. Opening nest boxes too early will reduce the females' interest. Dummy eggs can be placed in nests to encourage the birds to lay in them. Where automated systems are used, the egg gathering belts should be run several times each day, even before the arrival of the first egg, so that the birds become accustomed to the sound and vibration of the equipment.

The spacing of the bird's pin (pubic or pelvic) bones should be measured to determine the state of sexual development of the female. For further information on monitoring pin bone spacing refer to the section on Assessment of Bird Physical Condition.

KEY POINTS

- Achieve target body-weight by concentrating on correct weekly incremental feed increases and resultant bird gains.
- Follow the recommended lighting program.
- Monitor flock uniformity, body weight and feed clean-up time, and respond quickly to any issues.
- Provide ad libitum access to clean, good quality water.
- Change from grower to breeder layer feed at 5% production at the latest.
- Open nest boxes just before anticipated arrival of first egg.
- Measure pin-bone spacing.

Floor Eggs

Floor eggs represent a loss in production and a hygiene risk to the hatchery. Appropriate training of birds to lay eggs in the nests will reduce floor eggs, but there are a number of other practices which can reduce the occurrence of floor eggs.

- Introduce perches from 28 days (4 weeks).
- Incorporate a suitable alighting/perching rail in nest box design.
- Ensure male and female sexual maturity is synchronized.
- Have uniform distribution of light of greater than 60 lux (5.6 foot candles); avoiding the presence of dark and shaded areas next to walls, corners, and in the areas next to steps and slat fronts.
- Provide correct feeder space for females.
- Follow the recommended lighting program and ensure that light stimulation is synchronized with body weight.
- Where automated systems are used, the egg gathering belts should be run several times each day.
- Open nest boxes just prior to the anticipated arrival of the first egg and not too soon before.
- Walk around the house as frequently as possible (at least 6 and up to 12 times a day) picking up any floor eggs. This will prevent floor eggs being laid habitually.
- Set feeder and drinker heights appropriately so that they are not obstacles to nest access.
- Manage early mating ratios to avoid over-mating.
- With manual nests, put 20% at floor level to start. Thereafter, gradually raise them (over a period of 3 to 4 weeks) to the normal height.
- Allow 3.5 - 4 hens per nest hole for manual nests.
- Allow 40 hens per linear meter (12 birds per linear foot) for mechanical (communal type) nests.
- Ensure environmental conditions are adequate and avoid drafts in the nesting places.
- Set feeding times to avoid the peak of egg laying activity. Feeding time should be either within 30 minutes of 'lights on', or 5-6 hours after 'lights on' to prevent birds from feeding when most eggs are likely to be laid.

KEY POINT

- Attention to detail avoids floor eggs.

Management of Females from 5% Hen-day Production Until Peak Egg Production

Objective

To promote and support female reproductive performance throughout the laying cycle.

Principles

Hatching egg production performance is affected by early egg size, egg quality, and level of peak production. Correct body weight during early lay can be achieved by providing females with feed levels that will meet the increased demands of egg production and growth.

Management Considerations

For equipment, stocking density, and feeder and drinker space recommendations, see **Tables 10** and **11** (15 weeks to light stimulation).

Females must continue to gain weight during early lay to maximize egg production and hatchability. Birds should be fed to meet the increased demands of egg production and growth; but over-feeding must be avoided. Birds that receive more feed than required for egg production will develop an abnormal ovarian structure and gain excess weight - resulting in poor quality eggs, low hatchability, and increased risk of peritonitis and prolapse.

The difference in feed quantity allocated prior to first egg and the target feed level given at peak (see the Ross Parent Stock Performance Objectives for more details) allows a feed allocation schedule to be established. Amounts of feed given up to and at peak should then be adjusted for each individual flock depending on:

- Hen-day production.
- Daily egg weight and change in egg weight trend.
- Body weight and body-weight gain trend.
- Feed clean-up time.
- Dietary energy density.
- Operational environmental temperature.
- Degree of body fleshing and fatness.

Responsive management of birds coming into production requires frequent observation and measurement of the production parameters given above. These parameters are not used in isolation but rather in combination to determine whether or not the feed allocation for an individual flock is correct. Both the absolute and trend data should be taken in to account. For example, if there is an unexpected change or deviation from target in hen-day production, egg weight, body weight, or feed clean-up time, then feed allocation should be reviewed. However, in order for the manager to make informed decisions on feed quantity, dietary energy content and environment temperature must also be known. The frequency with which each of those parameters should be measured is given in **Table 12**. Monitoring of body weight, daily egg production and daily egg weight are key when determining feed allocations.

Table 12: Frequency of observation of important production parameters.

Parameter	Frequency
Egg production	Daily
Increase in egg production	Daily
Egg weight	Daily
Body weight	Daily
Body-weight gain	Daily
Feed clean-up time	Daily
House temperature (min. and max.)	Daily
Body condition and fleshing	Weekly (and on walk-through)

Feed increases given should be proportional to actual rates of production. Thus, in high producing flocks extra feed may need to be given, and feed increases beyond recommended peak feed amounts may be justified. Equally if egg weight and/or body weight are judged to be markedly below the expected target then feed increases should be advanced. Small but frequent feed increases to peak feeding levels should be used to prevent excessive weight gain.

Management requirements for each flock will vary depending on their body condition, reproductive performance, environment, equipment, and facilities. The following example (**Table 13**) shows how a feeding program can be devised for a particular flock, taking into account flock history, type of housing, feed composition and management constraints. It illustrates feed increases from 5% production; which is appropriate for flocks with CV less than 10%. If flock CV% is greater than 10, the first feed increase should be delayed until 10% production.

Table 13: Example female feeding program to peak egg production (for further details refer to the Ross Parent Stock Performance Objectives). Feeding program for a 24 week old flock on 368 kcal ME/bird/day (131.5 g/bird/day or 28.9 lbs/100 birds/day), based on a feed energy level of 2800 kcal ME/kg (11.7 MJ/kg) or 1270 kcal ME/lb. Average daily temperature is assumed to be 20-21°C (68-70°F) and the flock is assumed to be on target body weight with good uniformity.

Hen-day %	ROSS 308			ROSS 708		
	Daily Energy Intake (kcal/bird/day)	Feed Amount* g/bird/day (lb/100 birds/day)	Feed Increase g/bird/day (lb/100 birds/day)	Daily Energy Intake (kcal/bird/day)	Feed Amount* g/bird/day (lb/100 birds/day)	Feed Increase g/bird/day (lb/100 birds/day)
5	386	138 (30.4)	7 (1.4)	354	127 (27.9)	11 (2.2)
10	395	141 (31.1)	3 (0.7)	362	130 (28.6)	3 (0.7)
15	403	144 (31.8)	3 (0.7)	371	133 (29.2)	3 (0.6)
20	410	147 (32.3)	3 (0.5)	379	136 (29.9)	3 (0.7)
25	418	150 (33.0)	3 (0.7)	388	139 (30.5)	3 (0.6)
30	427	153 (33.6)	3 (0.6)	396	142 (31.2)	3 (0.7)
35	434	155 (34.2)	2 (0.6)	404	145 (31.9)	3 (0.7)
40	441	158 (34.7)	3 (0.5)	413	148 (32.5)	3 (0.6)
45	448	160 (35.3)	2 (0.6)	421	151 (33.2)	3 (0.7)
50	455	163 (35.8)	3 (0.5)	430	154 (33.8)	3 (0.6)
55	462	165 (36.4)	2 (0.6)	438	157 (34.5)	3 (0.7)
60	469	168 (36.9)	3 (0.5)	446	160 (35.2)	3 (0.7)
65	469	168 (37.0)		446	160 (35.3)	
70	469	168 (37.0)		446	160 (35.3)	
Peak	469	168 (37.0)		446	160 (35.3)	

*Figures in this table are rounded.

Table Notes: (a) Flocks can consume 115-135 g (25-30 lb per 100 birds per day) of feed per bird per day prior to 5% hen-day production; feeding programs should be adjusted according to given start point. (b) Uniform flocks will come into production rapidly and feed amounts should be adjusted (increased) accordingly. (c) Even though the table shows feed increases every 5% production, it may be necessary to adjust feed levels daily, taking into account the rate of daily production. (d) If feed energy levels different to 2800 kcal (11.7 MJ) ME/kg feed are used then feed intake will need to be adjusted accordingly. (e) Peak production is assumed to occur around 6 weeks after 5% production is achieved. (f) Adjustments will need to be made if environmental temperature is warmer (reduce feed intake) or cooler (increase feed intake) than that assumed here.

KEY POINTS

- Monitor and achieve target body weight and body-weight gains.
- Monitor daily egg production and egg weight.
- Stimulate egg numbers from 5% production by giving programmed increases in feed allocation.
- Follow the recommended lighting programs.
- Define the program of feed increases based on feed amount prior to production, dietary energy level, ambient temperature and expected flock productivity.
- Use small but frequent feed increases.

Feed Clean-up Trends

Feed clean-up time is a useful monitoring practice for ensuring that the flock is getting adequate energy intake. Clean-up time is the time it takes for the flock to eat its daily feed allocation (from when the feeder starts to operate until there is only dust left in the feeder). When the amount of feed being offered is excessive, birds will take longer to consume it, conversely when there is not enough feed birds will consume it more quickly than expected. Many factors affect clean-up time including age, temperature, feed amount, physical feed characteristics, feed nutrient density, and ingredient quality. Therefore, trends (changes) in feed clean-up time are as important as absolute time taken to clean-up feed. Feed clean-up time trends should be monitored and recorded, and if there is a change in clean-up time possible causes (energy levels not as expected, poor feed quality, health issues, incorrect feeding volumes) should be investigated.

At peak production, feed clean-up time is normally in the range of 2 to a maximum of 4 hours at 19-21°C (66-70°F) dependent on feed physical form (**Table 14**).

Table 14: A guide to feed clean-up times at peak production.

Feed Clean-up Time at Peak Production (hours)	Feed Texture
3-4	Mash
2-3	Crumble
1-2	Pellet

KEY POINT

- Monitor feed clean-up times and trends in feed clean-up times, and respond to any changes in feed consumption trends.

Egg Weight and Feed Control

Trends in daily egg weight act as a sensitive indicator of the adequacy of total nutrient intake (inadequate nutrient intake will lead to a fall in egg weight, and excessive nutrient intake will lead to an increase in egg weight). Feed intake should be adjusted according to deviations from the expected daily egg weight profile.

Daily egg weight should be recorded from 10% hen-day production. A sample of 120-150 eggs should be bulk weighed (**Figure 58**) daily. The eggs should be taken from eggs collected directly from the nest at second collection to avoid using eggs laid the previous day. Double-yolked, small, and abnormal eggs (e.g. soft shelled) should be rejected.

Figure 58: Bulk weighing of eggs.

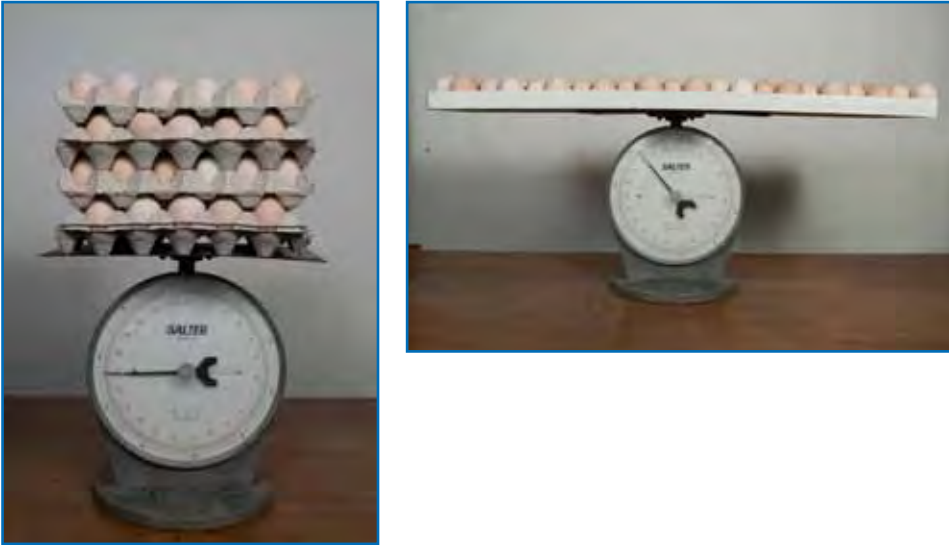

Average daily egg weight is obtained by dividing the bulk weight (weight of eggs minus weight of tray or trays) by the number of eggs weighed. The daily egg weight should then be plotted against target (it is important that the graph scale is large enough to make daily variation clearly visible). In flocks receiving the correct quantity of feed, egg weight will normally follow the target profile. However, it is normal for average egg weight to fluctuate on a daily basis due to sampling variation and environmental influences (**Figure 59**).

Figure 59: An example showing normal fluctuations in the daily weight of bulk weighed eggs.

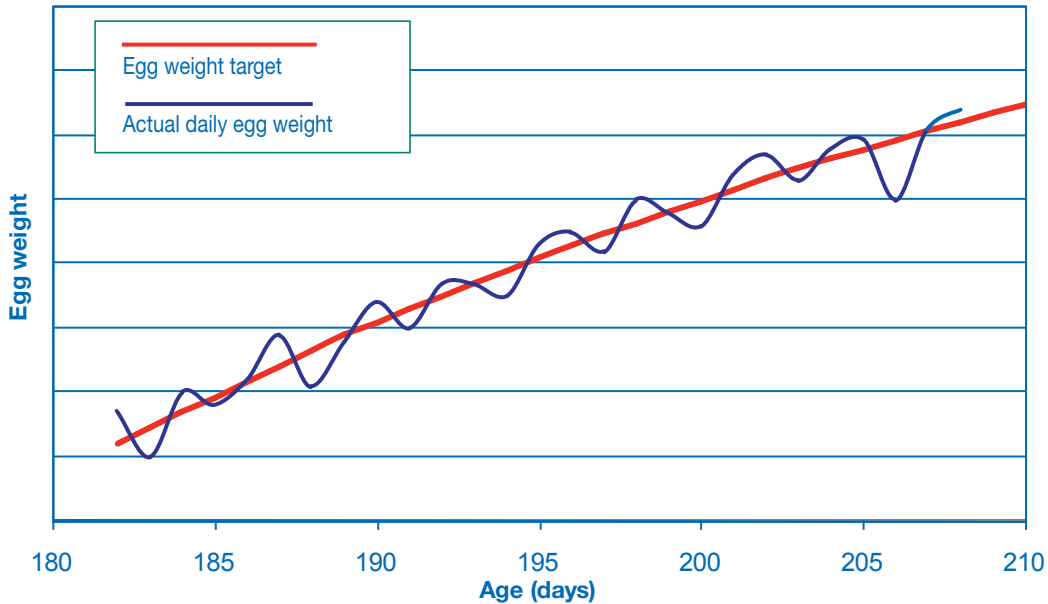

If the flock is being under-fed, egg size will not increase over a 3-4 day period, and egg weight will deviate from target (**Figure 60**). If peak feed amount has not been reached, the next planned feed increase should be brought forward to correct this. If peak feed has been reached then an additional increase in peak feed amount will be required (3 to 5 g [0.1 to 0.2 oz] per bird).

Figure 60: Example of reduction in average daily egg weight over a 3 to 4 day period due to inadequate feed intake.

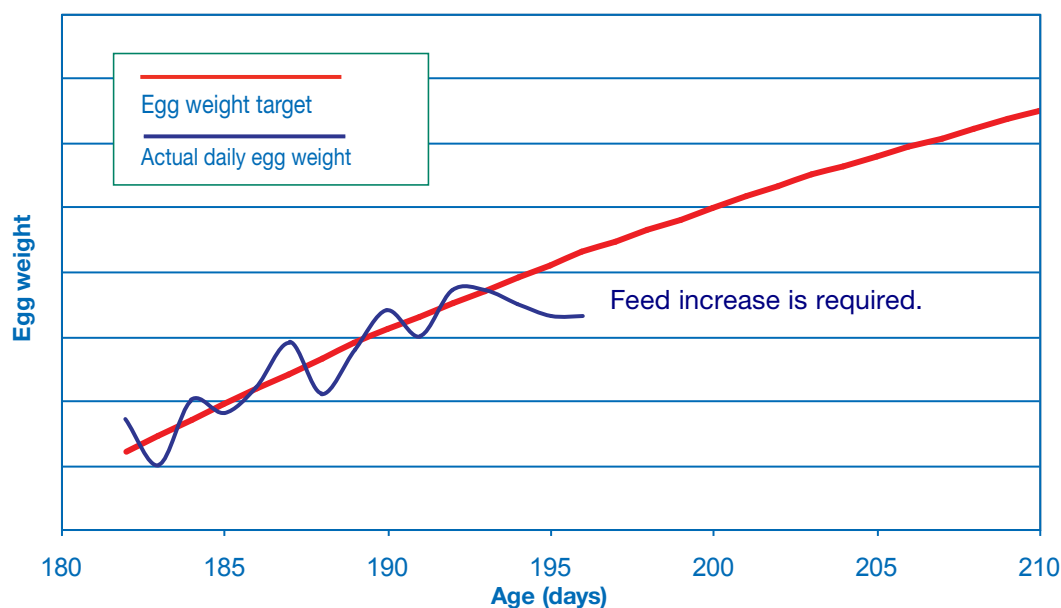

KEY POINTS

- Bulk weigh samples of eggs and record average daily egg weight from 10% hen-day production.
- Weigh eggs from the second collection to avoid using eggs from the previous day.
- Monitor daily egg weight trends by plotting against target.
- Respond promptly to falling daily egg weight trends by increasing feed allowance.

Management of Males Post Light Stimulation Until Peak Egg Production

Objective

To optimize fertility and ensure persistency of flock fertility.

Principles

Females require the correct number of males which are in optimal physical condition.

Feeding Considerations

Control of male body weight during the period between light stimulation and peak can be difficult, as males become progressively excluded from the female feeders. Body condition, average body weight, and body-weight gains should be monitored ideally twice a week during this period to ensure that the males remain in optimal physical condition and that body weight remains on target (see the Ross Parent Stock Performance Objectives for more details). Preventing males from becoming over- or underweight is only possible when separate-sex feeding systems are well maintained and managed.

Typically, males become excluded from female feeders from about 22 weeks of age but some males may continue to access the female feeders up until around 26 weeks of age. Frequent visits by personnel at feeding time to observe feeding behavior are essential at this time. Failure to detect when the males are excluded from the female feeders is a common cause of male body weight shortfall in the pre-peak period and has serious implications for early and late fertility.

Males stealing female feed, particularly when the flock is between 50% hen-day egg production and peak, may lead to males becoming overweight and the females becoming underweight with a consequential marked reduction in peak egg production levels. Monitoring female factors such as daily egg weight and body weight will indicate if this problem is occurring. If males are stealing female feed there will be a shortfall in average daily egg weight trends and female body weight; and then subsequently egg production will drop.

Underfeeding

Underfeeding of males can occur during the early stages of production after mixing of males and females. This is because mating behavior at this stage is very active and the male bird has not yet reached physical or physiological maturity so nutrient requirements are high. Males will become dull and listless, showing reduced activity and less frequent crowing if they are being underfed. If these symptoms are missed and the condition progresses, the comb and wattles become flaccid, there will be a loss of body weight and body condition, reduction in face and vent color, and eventually molting will occur. The last stage (molting) cannot be recovered from. On observing any combination of these symptoms immediately check clean-up time, feeding space per bird, and separate-sex feeding systems. Next, the accuracy of weekly average weight gain data should be verified and a sample of males (10% of the population) reweighed. If inadequate body weight is verified feed allowance should be increased by 3-5 g/bird/day (0.7-1.1 lb/100 birds/day) without delay. Prompt action is essential.

Overfeeding

Excessive feed consumption in males may occur due to oversupply (inaccurate weighing of feed), variation among males in intake, or feeding from female feeders (inadequate measures to ensure male exclusion). If body weight control is poor, a sub-population of heavy males with excessive breast development may occur. Females will begin to avoid mating if a considerable percentage of males are overweight. Additionally, over-fleshed males may become impaired in their ability to successfully complete matings. Overweight males losing condition will be among the first to undergo testicular regression and associated reductions in mating activity and fertility will occur. Excessively overweight males (10% or more over target weight) should be carefully assessed and removed from the flock if they are not mating (see section on Assessment of Bird Physical Condition).

KEY POINTS

- Monitor male physical condition (fleshing) and body weight weekly.
- Grow males to the target body weight and achieve target weekly body-weight gains.
- Use separate-sex feeding with adequate well maintained equipment.
- Routinely observe feeding behavior.
- Any shortfall or reduction in male body weight has serious implications for fertility.
- Consider removing overweight males (10% or more over target weight) from the flock.

Mating Ratio

To maintain fertility throughout lay, each flock will require an optimum number of sexually active males. As the flock ages and egg production declines, fewer males are required to maintain fertility (**Table 15**), so substandard and non-working males can be progressively removed from the flock as it ages. The mating ratios given below are a guide only and should be adjusted according to local circumstances and flock condition. Higher ratios than those given in the table may be required in open-sided laying houses where mating activity may be lower due to high environmental temperatures.

Table 15: A guide to typical mating ratios as a flock ages.

Age		Number of Good Quality Males Per 100 Females
Days	Weeks	
154 - 168	22 - 24	9.50 - 10.00
168 - 210	24 - 30	9.00 - 10.00
210 - 245	30 - 35	8.50 - 9.75
245 - 280	35 - 40	8.00 - 9.50
280 - 350	40 - 50	7.50 - 9.25
350 to depletion	50 to depletion	7.00 - 9.00

Mating ratio should be reviewed weekly. Based on an assessment of physical condition and body weight, any males considered to be non-working should be removed from the flock in line with recommendations to achieve suggested mating ratios. Males retained for mating should have the following characteristics (see section on Assessment of Bird Physical Condition for more information):

- Uniform in body weight.
- Free of physical abnormalities (alert and active).
- Strong, straight legs and toes.
- Well feathered.
- Good upright stance.
- Good muscle tone and body condition.
- Comb, wattles and vent showing evidence of mating activity.

The removal of non-working males from the flock should be a continuous process. Removing a large number of males at one time will lead to unnecessary stress.

Over-mating

A surplus of males leads to over-mating, interrupted mating, and abnormal behavior. Over-mated flocks will exhibit reductions in fertility, hatchability, and egg numbers. In the early stages, after mating-up, it is quite normal to observe some displacement and wear of the feathers at the back of the female's head and of the feathers on the back at the base of the tail. When this condition progresses to the removal of feathers, this is a sign of over-mating. If the mating ratio is not reduced, the condition will worsen with de-feathering of areas of the back and skin scratches occurring. This may lead to low welfare, loss of female condition, and reduced egg production. Excessive injuries and feather damage to the males as a result of fighting may also occur. Over-mated females may be seen "hiding" from the males beneath equipment, in nest boxes, or refusing to come down from the slatted area.

Surplus males must be removed quickly or a considerable loss in persistency of male fertility will result. The signs of over-mating generally become more obvious at around 182 to 189 days (26 to 27 weeks) , becoming most apparent by 210 days (30 weeks), but the flock should be examined for signs of over-mating on a daily basis from 175 days (25 weeks) onwards. When over-mating occurs, the removal of males from the flock should be advanced with an additional one-off removal of males from the flock. An additional 1 male per 200 females should be removed and then the planned pattern of reduction (1 male per 200 females every 5 weeks – see **Table 15**) should continue to be followed.

KEY POINTS

- As the flock ages, fewer males are required to maintain flock fertility.
- Substandard and non-working males should be continuously removed as the flock ages.
- Review mating ratios weekly.
- Monitor females for signs of over-mating from 25 weeks of age.
- Whenever over-mating occurs, surplus males must be removed as quickly as possible; inspect males and remove those that are not working.

Section 3 - Management in Lay (Peak to Depletion)

Management of Females After Peak Production Through to Depletion

Objective

To maximize the number of fertile hatching eggs produced per female, by ensuring persistency of egg production post-peak.

Principles

To maintain productive performance beyond peak production, females must gain body weight close to the recommended target. Failure to control body weight, and thus fat deposition, post-peak can significantly reduce persistency of lay, shell quality, and female fertility, and it can increase egg size after 40 weeks of age.

Factors for Post-peak Management

Post-peak females must gain body weight close to the recommended target. If body-weight gain is inadequate, total egg production will be reduced. If body-weight gain is too rapid, post-peak production persistency and fertility will be lowered.

Shortly after peak production, maximum nutrient requirements for egg production occur. This is because egg mass continues to increase after there has been some reduction in rate of lay. Peak egg production is usually achieved around 217 days (31 weeks) and can be defined as no increase in daily hen-day production over a 5 day period. Shortly after this, at around 224 to 231 days (32 to 33 weeks) peak egg mass occurs.

$$\text{Egg Mass} = \frac{\text{average egg weight (g)} \times \text{egg production (Hen-week \%)}}{100}$$

From the time of peak production growth should continue - but at a slower weekly rate (see the Ross Parent Stock Performance Objectives for more information).

After peak feed has been given and peak egg production has occurred, feed reductions will be required in order to achieve the recommended target body weight and to limit the rate of fat deposition as egg production declines. Post-peak feed reductions should start when hen-day production does not increase over a period of 5-7 days and ensure that good persistency is maintained by controlling body weight gain to 15-20 g/female/week (3.3- 4.4 lbs/100 females/week), to manage egg weight gains and therefore egg mass.

Figure 61: The relationship between growth, body weight, egg production, egg weight, egg mass, and age.

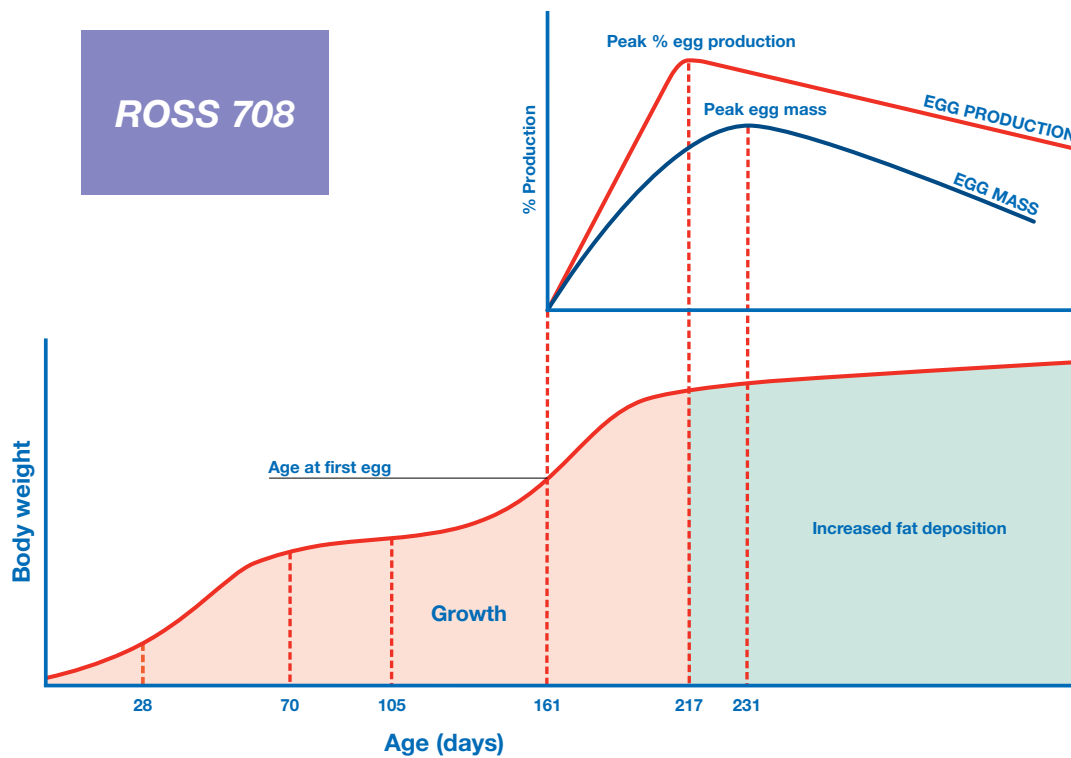
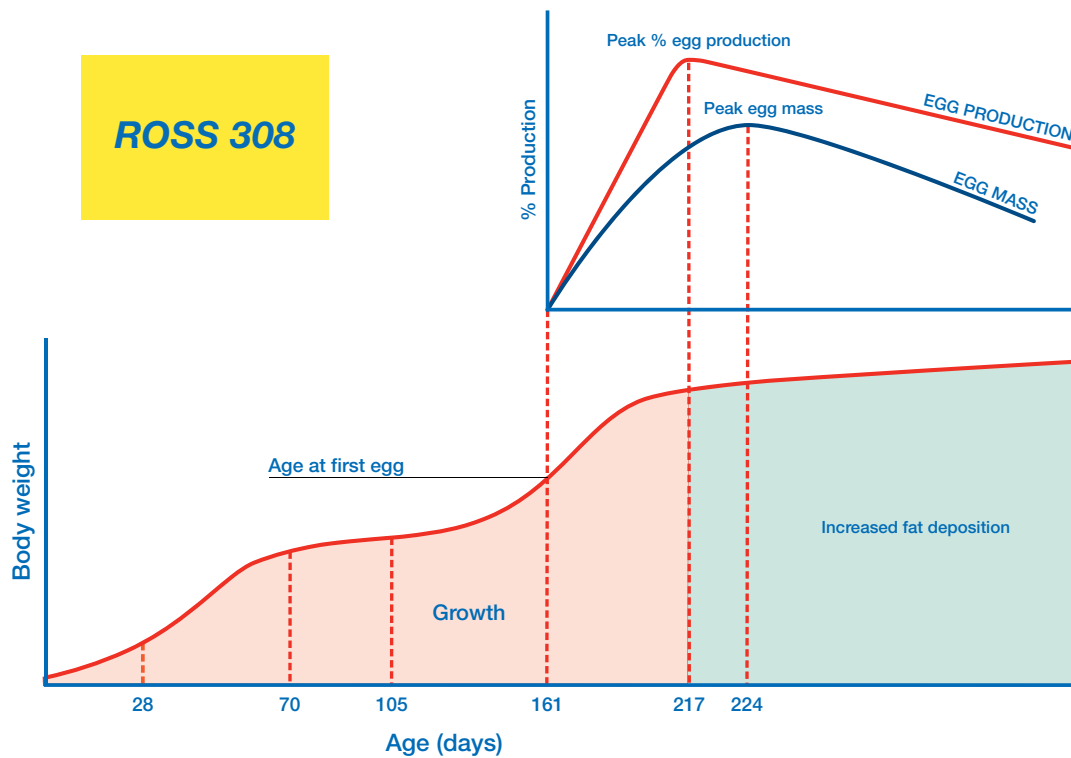

Procedures

Many factors are involved in determining the exact timing of the initial feed reduction post-peak. Timing and amount of feed reduction may be affected by:

- Body weight and body-weight change from the start of production.
- Daily egg production and the hen-day production trend.
- Daily egg weight and egg weight trend.
- Egg mass trend.
- Health status of the flock and feathering condition.
- Ambient environmental temperature.
- Feed energy and protein levels.
- Feed texture.
- Feed quantity consumed at peak (energy intake).
- Flock history (rearing and pre-peak performance).
- Changes in feed clean-up time.
- Feather cover.

Due to variation between flocks in the characteristics given above, the program of feed reduction will vary for each flock. To enable the farm manager to monitor and establish an appropriate feed reduction program, it is critical that the following characteristics are measured and recorded, and graphed onto a chart:

- Daily (or weekly) body weight and body-weight change relative to the target (see the Ross Performance Objectives for more details on target body weights). Accurate body weight monitoring is critical during the post-peak period (see section on Monitoring Broiler Breeder Growth).
- Daily egg weight and egg weight change relative to the target (can be obtained from the Performance Objectives booklet).
- Daily changes in feed clean-up time. Clean-up time is the time between feeder switch-on and trough clearance; at peak these are normally 3-4 hours for mash, 2-3 hours for crumbles, 1-2 hours for pellets. If clean-up time is more or less than the times indicated it suggests that feed levels may be too high or too low respectively.

In addition, the farm manager should routinely handle and examine the birds to ensure they are in good physical condition (see section on Assessment of Bird Physical Condition for more information).

General Guidelines for Post-peak Feed Reductions Based on Target Performance Characteristics

Under moderate temperate conditions where performance levels are close to or on target, the following illustrates general guidelines for feed reductions after peak. However, the actual program of feed reduction should be based on the close and accurate monitoring of daily body weight, daily egg weight and feed clean-up time.

Ross 308 - Parent Stock	
Age	
Peak* to 35 weeks	Hold at peak feed levels
36-50	Gradual reductions down to 444 kcal ME/bird/day, 159 g/bird/day (35.1 lbs/100 birds/day)
>50 weeks	Gradual reductions down to 421 kcal ME/bird/day 150g/bird/day (33.2 lbs/100 birds/day) minimum.

Ross 708 - Parent Stock	
Age	
Peak* to 36 weeks	Hold at peak feed levels
37-50	Gradual reductions down to 425 kcalME/bird/day, 152 g/bird/day (33.5 lbs/100 birds/day).
>50 weeks	Gradual reductions down to 405 kcal ME/bird/day 144 g/bird/day (31.9 lbs/100 birds/day) minimum.

*Peak expected to occur around 31 weeks of age.

There will be situations where flock performance differs markedly from the published performance targets and the feed reduction program will need to be altered accordingly to account for this. The following are examples of 2 specific field situations illustrating suggested feed reduction strategies where performance differs from published targets.

Flocks performing above target recommendations

Flocks performing above the published performance targets can be under-supplied in feed and thus nutrients, and both body weight and egg weights may start to slow or fall off when compared to the expected incremental gain (see example in **Figure 62**). Excessive feed reductions after peak can potentially have a negative impact on production and leave birds susceptible to molting and broodiness. When flocks are performing above target recommendations feed reductions after peak should be less and more gradual; peak feed may need to be held for longer, onset of feed reduction delayed and less feed reduced overall from 35 weeks to depletion.

Figure 62: A graph illustrating the effects of underfeeding a flock performing above the hen week production target.

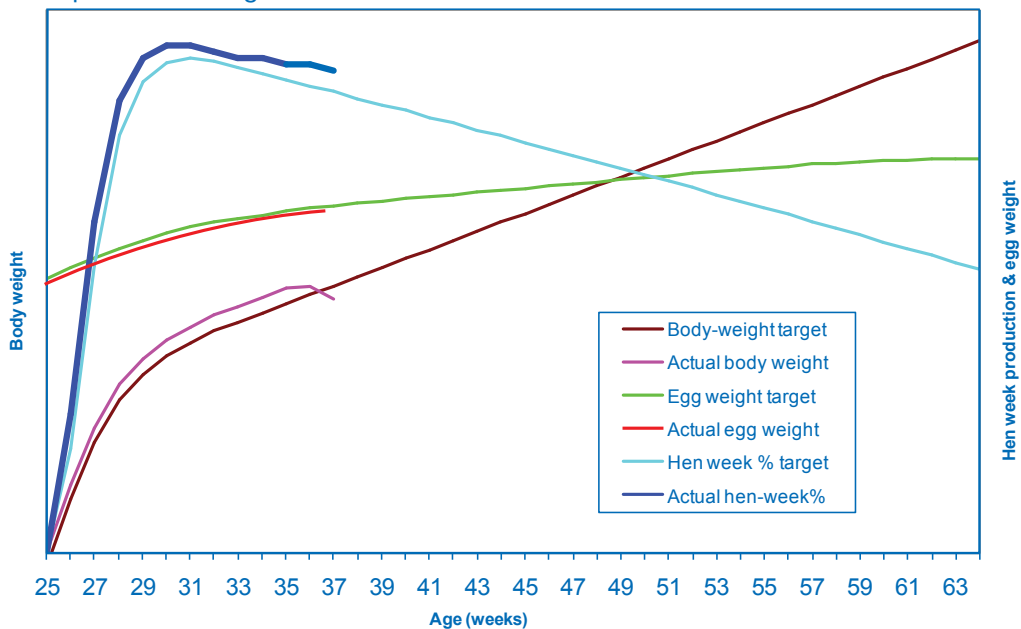

Daily egg weight, body weight, production, and feed clean-up times should be monitored closely. In particular, recording and monitoring body weight and egg weight will indicate if feed reduction is being done correctly. Under normal conditions, a fade in egg weight and then body weight are the first signs that feeding is not correct, and will precede a drop in production. In **Figure 62**, the graph illustrates a flock performing above target, where the information has been collated and graphed weekly. While general trends in performance can be monitored in this way, weekly recording does not allow sufficient early detection of potential performance issues in egg and body weight. Small, but important changes will occur within days if nutrition is inadequate and it is recommended that daily egg weights and body weights are measured, recorded, and monitored separately so that any fade in weight can be rapidly detected and acted upon (**Figures 63 and 64**).

Figure 63: An example of a flock performing above hen week target, where egg weight is falling away from the expected target in a consistent and continuous way over a period of at least 4 days.

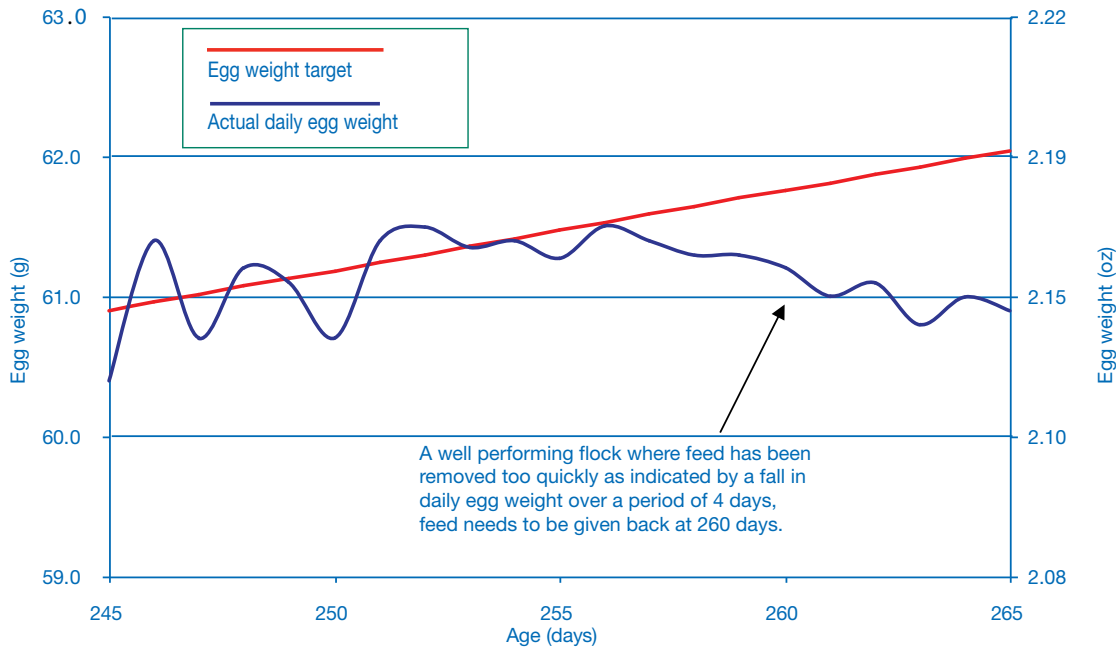
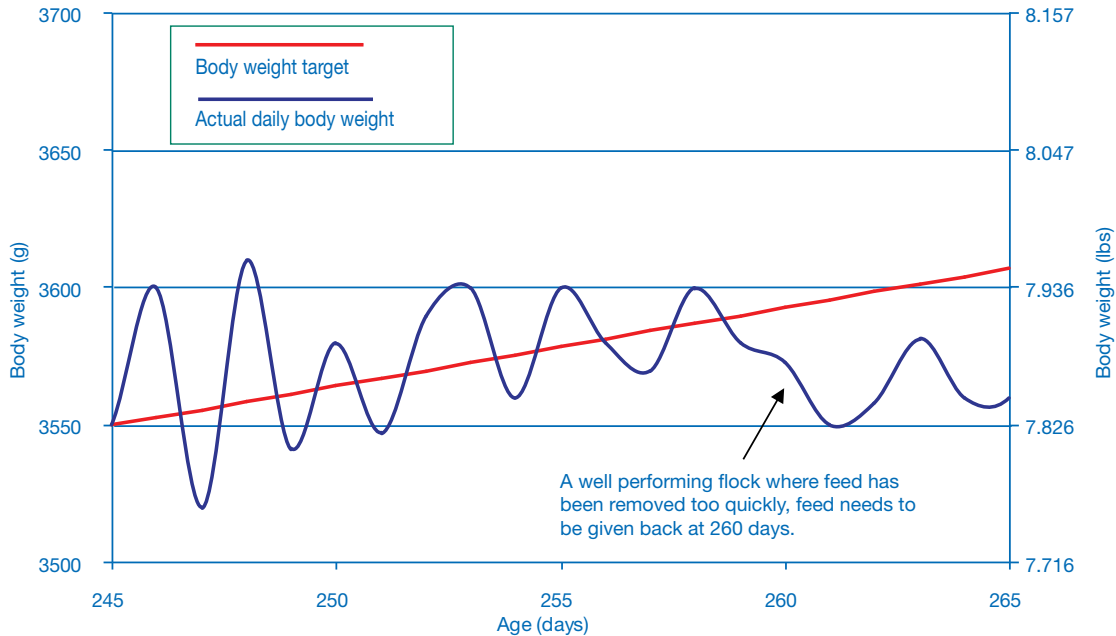

Figure 64: An example of a flock performing above hen week target, where body weight is falling away from the expected target in a continuous and consistent way.



Flocks performing below target recommendations

For flocks that perform below the published performance targets, feed reduction can be greater. Excess feed levels will result in such flocks becoming overweight with poor persistency and increased egg weight (see **Figure 65**). Daily egg weight, body weight, production and feed clean-up times should be monitored closely to determine if feed reduction is being done correctly. In flocks that are performing below target recommendations the overall feed reduction from peak to depletion will be more when compared to higher performing flocks. Initial feed reductions after peak can be in the range of 2-4 g (0.07-0.14 oz) or 8-11 kcal ME per week.

Figure 65: A graph illustrating a flock performing below the hen week production target.

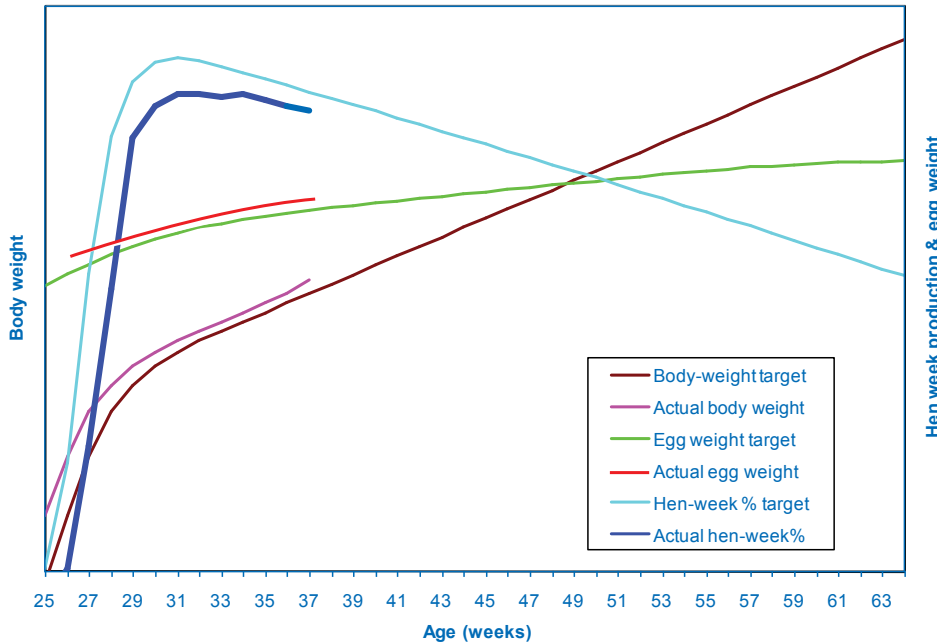

The early detection of potential performance issues requires that daily egg weights and body weights are measured, recorded and monitored separately. **Figures 66** and **67** illustrate how closer daily examination of the data (rather than weekly as illustrated in **Figure 65**) indicates where there was a higher than expected increase in egg weight and then body weight as feed reductions after peak have been too slow.

Figure 66: An example of a flock performing below hen week target where the increase in daily egg weight becomes continuously and consistently higher than expected over a period of at least 4 days.

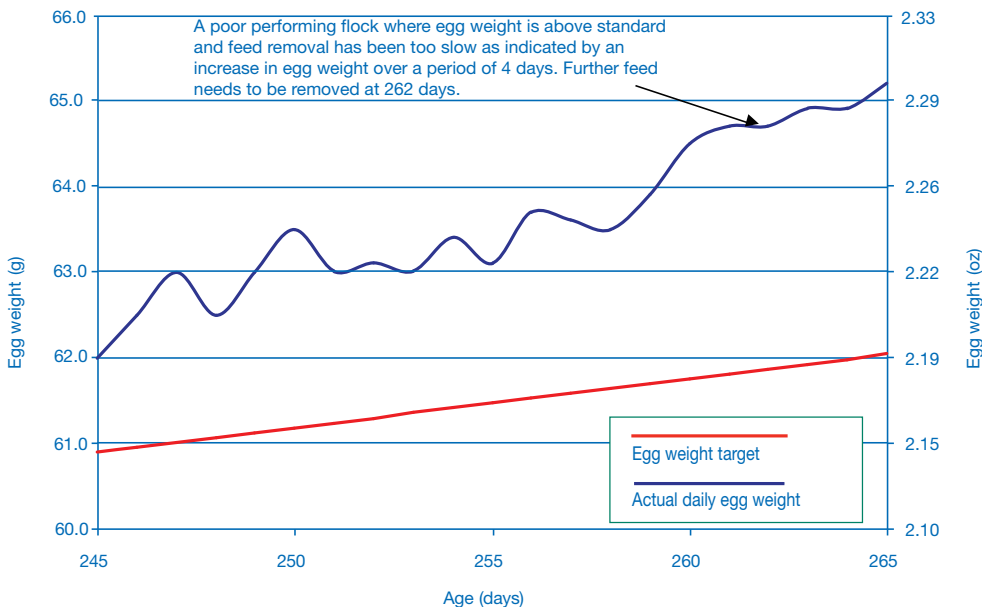
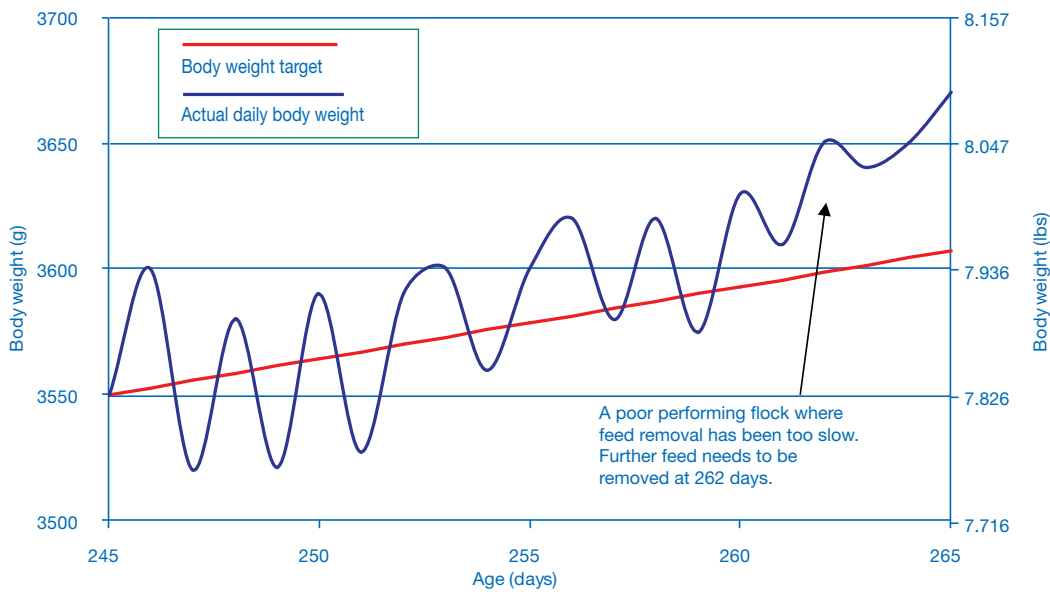

Figure 67: An example of a flock performing below hen week target where the increase in daily body weight becomes continuously and consistently higher than expected.



Monitoring Feed Reduction

In any flock (high, average, or low producing) after any feed reduction, the response to that feed reduction should be monitored carefully. If production, egg weight or body weight decreases more than expected, restore the feeding amount to the previous level and attempt to reduce the feed level again 5-7 days later (Figures 68 and 69).

Figure 68: An example of re-assessment of feed removal when the daily egg weight decreases in a consistent and continuous way by more than expected and feed levels need to be increased again.

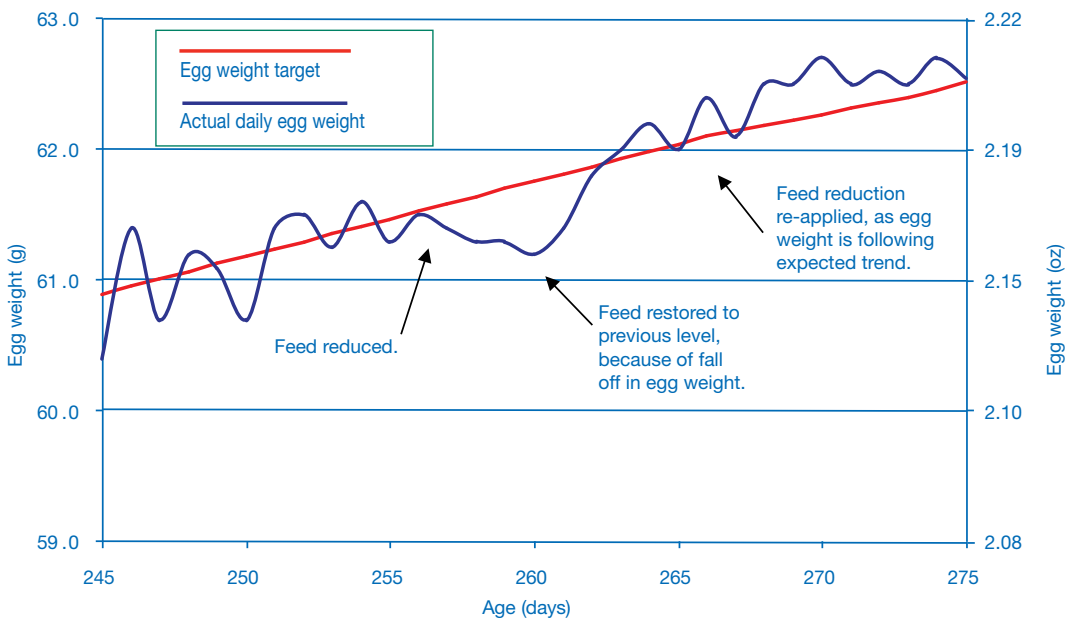
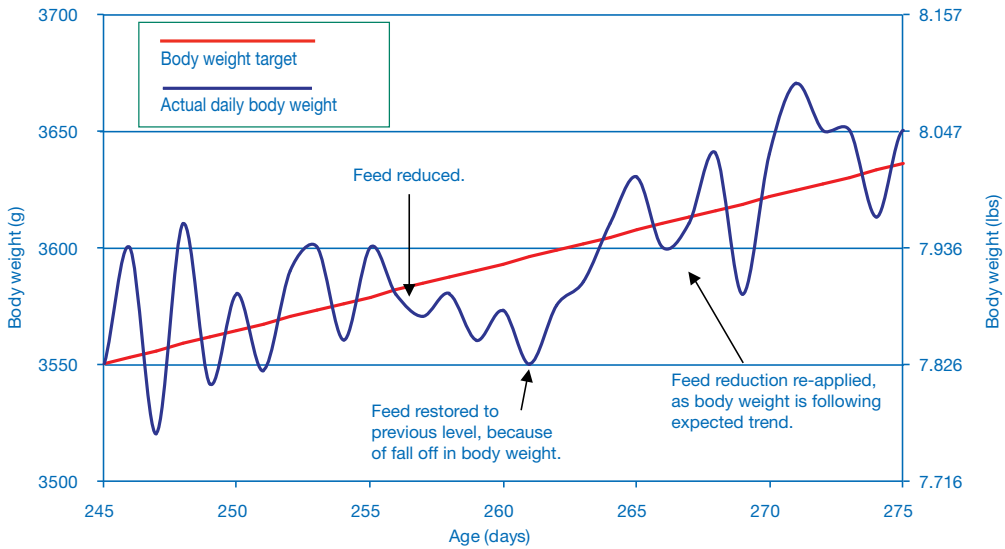

Figure 69: An example of re-assessment of feed removal when the daily body weight decreases in a consistent and continuous way by more than expected and feed levels need to be increased again.



If egg weight or body weight increases more than expected and a fall off in persistency occurs the next feed reduction should be advanced (**Figures 70 and 71**).

Figure 70: An example of re-assessment of feed removal when the daily egg weight increases in a consistent and continuous way by more than expected and feed levels need to be reduced again.

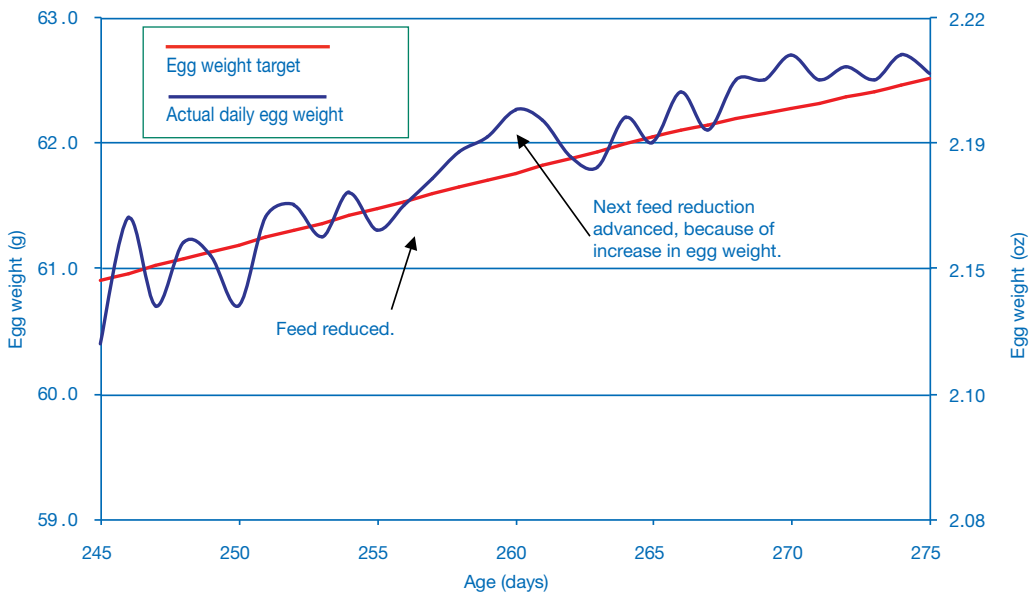
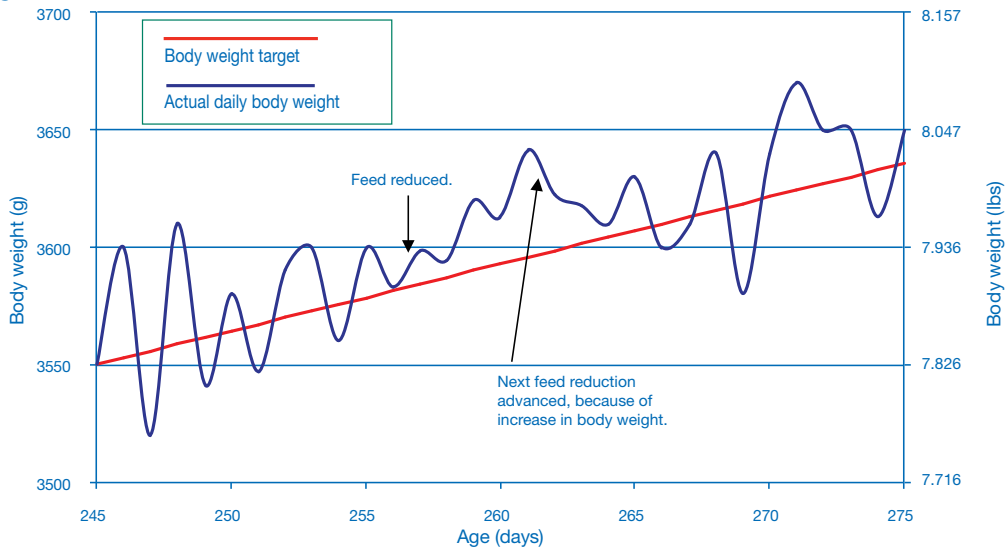

Figure 71: An example of re-assessment of feed removal when the daily body weight increases in a consistent and continuous way by more than expected and feed levels need to be reduced again.



Feed Reductions and Environmental Temperature

If flocks peak during hot weather, feed should be reduced sooner and more quickly compared to more temperate conditions. However, as ambient temperatures decrease, feed levels should be reviewed and adjusted accordingly to ensure that birds' energy requirements are achieved. Monitor feed clean-up time so that any variations are managed.

KEY POINTS

- Monitoring and control of body weight and egg weight are major priorities post-peak.
- Follow a feed reduction program that allows the birds to gain weight at a rate of 15 to 20 grams per week (0.5-0.7 oz). This will help attain egg production, body weight and egg weight profiles.
- Failure to control body weight from peak production will reduce production persistency and effect egg size.
- Monitor and record daily body weight and egg weight and make weekly feeding decisions based on these daily trends in relation to target. If trends indicate, then make changes in feed allowances earlier.
- Flocks producing at levels above egg production targets may require more feed. Feed reductions should be of smaller amounts and more gradual.
- If a flock peaks poorly, the feed withdrawal should be more rapid to avoid birds becoming fat.

Management of Males After Peak Production Through to Depletion

Objective

To maintain persistency of fertility.

Principles

Maintaining male condition and feeding, and appropriately managing male numbers in lay are key for maintaining male fertility post-peak.

Procedures

Management principles and procedures for males in the post-peak period are similar to those used in the pre-peak period. Adjusting feed quantity to achieve a gradual but constant increase in weight as the male ages is the most effective means of controlling body weight and body condition. Thus persistency of fertility can be maintained. Mating ratios must also be optimized and managed.

Males should be weighed frequently (at least once a week) to ensure this is achieved. At the same time as each male is weighed, they should be evaluated to determine if they are maintaining ideal body condition, fleshing, and vent coloration. Maintaining these characteristics supports active mating activity throughout the flock's life. It is important that an adequate sample size is weighed and assessed. A sample size that is too small (less than 10% of the population) can mislead the farm manager (for more information, refer to the section on Monitoring Broiler Breeder Growth).

Changes in male feed quantities should be made based on the sample evaluated, using both body weight data and other husbandry information (such as body condition and fleshing). After 28 weeks of age, male weekly body-weight gain should be approximately 30 g (0.06 lb) per week. When males are on target body weight, and assuming that the separate-sex feeding is working correctly, the energy allowance post-peak is normally in the range of 375-425 kcal ME per bird per day; depending on feed energy density, environmental temperature and bird age (refer to the Ross Parent Stock Performance Objectives for more information).

Male feed allocations should continue to increase throughout the life of the flock. They should never be decreased. From around 30 weeks of age, males generally require one small feed increase approximately every 2 weeks to achieve the desired average weekly body-weight gain of 30 g (0.06 lbs).

A planned mating ratio reduction program should be followed to maintain persistency of fertility (see section on Management into Lay). The optimum mating ratio should be maintained by removing males according to their physical condition (see section on Assessment of Bird Physical Condition).

Flocks with footpad problems have reduced mating and lower fertility. Litter condition and slat construction have a major effect on male footpad health and ultimately on the ability to mate. If litter becomes wet, compacted, or of inadequate volume, additional litter must be added to give males (and females) a comfortable area to walk on and mate.

KEY POINTS

- Never decrease male feed allocation.
- Ensure sufficient sample size is weighed.
- Feed increases should account for body weight, fleshing and physical condition to maintain growth and persistency of fertility.
- Maintain adequate quantities of dry litter to promote good footpad health.
- Follow a planned male reduction program.

Section 4 - Monitoring Broiler Breeder Growth

Monitoring Broiler Breeder Growth

Objective

To manage bird development by obtaining an accurate estimate of the average body weight and uniformity (CV%) for each population of birds.

Principles

Weigh birds at least weekly using a standardized, accurate and repeatable procedure. Target body weight-for-age and flock uniformity can then be controlled by management of feed allowance and feed distribution so that reproductive performance is maximized.

Body Weight Weighing Methods

Flock growth and development are assessed by weighing representative samples of birds and comparing sample weights with target body weight-for-age.

All measurement systems require calibration and standard weights should be used to check that scales are weighing accurately. A calibration check should be made at the beginning and end of every sample weighing.

Two main weighing systems are available – manual and electronic. Either type of weighing scale can be used successfully, but the same scale should be used each time for reliable repeat measurements of an individual flock.

No matter which weighing system is used, the people handling birds should work in a calm manner, and be appropriately trained considering bird welfare at all times.

Manual weighing scales

Several types of manual scales are available (an example is given in **Figure 72**). These can be used to weigh birds to an accuracy of ± 20 g (0.04 lbs) and have a capacity up to 5 kg (11 lbs). Conventional (mechanical or dial) scales require manual data records to be kept and data calculations to be made manually.

Figure 72: Manual suspended balance for weighing birds.



Electronic weighing

Electronic scales (**Figure 73**) are available which record individual bird weights to the nearest gram (oz), and can calculate and print-out the population statistics (**Figure 74**) automatically:

- Total number of birds weighed.
- Average weight of birds.
- Deviation or range.
- CV%.

Figure 73: Examples of electronic weighing scales for individual chick weights up to 7 days (on the left), electronic scales for individual bird weights after 7 days (in the middle) and platform scales (on the right) where birds weigh themselves individually.

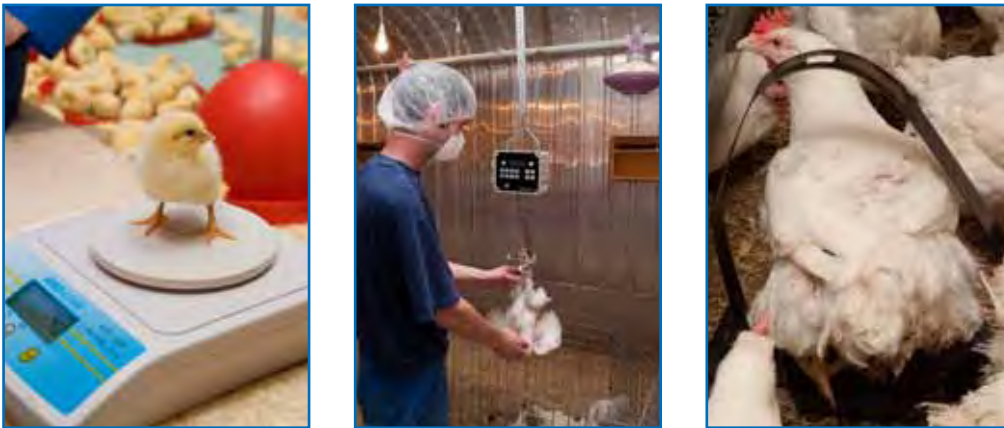

Figure 74: Examples of a print-out from an automatic weigh scale (metric and imperial).

CURRENT DATA METRIC		CURRENT DATA IMPERIAL	
TOTAL WEIGHED:	79	TOTAL WEIGHED:	79
AVERAGE WEIGHT:	0.471	AVERAGE WEIGHT:	1.037
DEVIATION:	0.048	DEVIATION:	0.105
C.V. (%):	10.2	C.V. (%):	10.2

Band limits	Total	Band limits	Total
0.320 to 0.339	1	0.705 to 0.747	1
0.340 to 0.359	1	0.750 to 0.791	1
0.360 to 0.379	2	0.794 to 0.836	2
0.380 to 0.399	2	0.838 to 0.880	2
0.400 to 0.419	4	0.882 to 0.924	4
0.420 to 0.439	7	0.926 to 0.968	7
0.440 to 0.459	12	0.970 to 1.012	12
0.460 to 0.479	15	1.014 to 1.056	15
0.480 to 0.499	14	1.058 to 1.100	14
0.500 to 0.519	10	1.102 to 1.144	10
0.520 to 0.539	6	1.146 to 1.188	6
0.540 to 0.559	3	1.190 to 1.232	3
0.580 to 0.599	2	1.279 to 1.321	2

Methodology for Sample Weighing

Birds should be weighed weekly from placement (day 0). At 0, 7 and 14 days of age, samples can be weighed in bulk. After 14 days of age, individual bird weights should be taken.

At placement (day 0), at least 3 boxes of chicks should be bulk weighed per pen. The number of live chicks in each box and the weight of the chick box must be known in order to accurately calculate average chick weight. In addition, it is recommended to individually weigh the chicks in one box per pen at placement to assess chick quality and help determine initial early chick management procedures.

From 7 days onward, a **minimum** sample of 2% or 50 birds whichever is greater should be weighed per population. At 7 and 14 days of age, bulk weigh 10-20 birds at a time until the entire sample (a minimum of 2% or 50 birds) has been weighed.

Bulk weighing allows the determination of average bird weight. Comparison of average bird weight to target weight, facilitates feeding decisions. However, for the determination of uniformity (CV%), birds need to be weighed individually.

Recording of individual bird body weights should occur as early as is practically possible, generally that is between 14 and 21 days (2 and 3 weeks) of age. A **minimum** sample of 2% or 50 birds (whichever is the greater) per population should be caught using catching frames, and then individually weighed. **All** birds captured in the sample must be weighed in order to eliminate any selective bias. In rear, if the individual population exceeds 1,000 birds, 2 sample weighings should be taken from different locations in the pen or house. In lay, samples should be taken from a minimum of 3 different locations within the population. In this way samples will be as representative as possible and estimates of body weight will have increased accuracy.

Birds for sample weighing should be caught towards the middle of the pen away from any doors or the sides of the pen. Weighing needs to be completed on the same day each week and at the same hour of the day (4-6 hours after feeding).

Procedures for Manual Scales

When manual scales are used individual bird weights should be recorded on a weight recording chart (**Figures 75 and 76**) as the birds are weighed.

Figure 75: Manual body weight recording chart for the Ross 308.

Body Weight Recording Chart



FARM		BREED	HOUSE	PEN	SEX	AGE	DATE
			2		Female	28	Mar-15
NUMBER WEIGHED	AVERAGE WEIGHT		TARGET WEIGHT		% Coefficient of variation		
212	464 g (1.02 lbs)		450 g (0.99 lbs)		10.3		

WEIGHT POUNDS	WEIGHT GRAMS	NUMBER OF BIRDS																													
		1	2	3	4	5	6	7	8	9	10	11	12	13	14	15	16	17	18	19	20	21	22	23	24	25	26	27	28	29	30
0.00	0.00																														
0.04	0.20																														
0.09	0.40																														
0.13	0.60																														
0.18	0.80																														
0.22	100																														
0.26	120																														
0.31	140																														
0.35	160																														
0.40	180																														
0.44	200																														
0.49	220																														
0.53	240																														
0.57	260																														
0.62	280																														
0.66	300																														
0.71	320																														
0.75	340	x	x	x	x	x																									
0.79	360	x	x	x	x	x	x	x	x	x	x	x																			
0.84	380	x	x	x	x	x	x	x	x	x	x	x	x	x																	
0.88	400	x	x	x	x	x	x	x	x	x	x	x	x	x																	
0.93	420	x	x	x	x	x	x	x	x	x	x	x	x	x	x	x	x	x	x												
0.97	440	x	x	x	x	x	x	x	x	x	x	x	x	x	x	x	x	x	x	x	x	x	x	x	x	x	x	x	x		
1.01	460	x	x	x	x	x	x	x	x	x	x	x	x	x	x	x	x	x	x	x	x	x	x	x	x	x	x	x	x		
1.06	480	x	x	x	x	x	x	x	x	x	x	x	x	x	x	x	x	x	x	x	x	x	x	x	x	x	x	x	x		
1.10	500	x	x	x	x	x	x	x	x	x	x	x	x	x	x	x	x	x	x	x	x	x	x	x	x	x	x	x	x		
1.15	520	x	x	x	x	x	x	x	x	x	x	x	x	x	x	x	x	x	x	x	x	x	x	x	x	x	x	x	x		
1.19	540	x	x	x	x	x	x	x	x	x	x	x	x	x																	
1.23	560	x	x	x	x	x	x	x	x	x	x	x	x																		
1.28	580	x	x	x	x	x	x	x																							
1.32	600																														
1.37	620																														
1.41	640																														
1.46	660																														
1.50	680																														
1.54	700																														
1.59	720																														
1.63	740																														
1.68	760																														
1.72	780																														
1.76	800																														
1.81	820																														
1.85	840																														
1.90	860																														
1.94	880																														

$$CV\% = \frac{\text{Range of Weights} \times 100}{\text{Average of Weights} \times F \text{ Value}}$$

Range is defined as the difference in weight between the heaviest and lightest birds. The appropriate F value depends on sample size. Examples are as follows:

Sample Size	F Value	Sample Size	F Value
10	3.08	60	4.64
15	3.54	65	4.70
20	3.73	70	4.76
25	3.94	75	4.81
30	4.09	80	4.87
35	4.20	85	4.90
40	4.30	90	4.94
45	4.40	95	4.98
50	4.50	100	5.02
55	4.57	105	5.03

Average Weight of populations	Metric	464	Imperial	1.02
Body Weight Range		240		0.53
CV% =	$\frac{240 \times 100}{464 \times 5.03}$	10.3	$\frac{0.53 \times 100}{1.02 \times 5.03}$	10.3
Flock Details:				
Age		28		28
Average Weight		464		1.02
Total Birds Weighed		212		212

Figure 76: Manual body weight recording chart for the Ross 708.

Body Weight Recording Chart



FARM	BREED	HOUSE	PEN	SEX	AGE	DATE
		2		Female	28	Mar-15
NUMBER WEIGHED	AVERAGE WEIGHT	TARGET WEIGHT		% Coefficient of variation		
212	464 g (1.02 lbs)	400 g (0.88 lbs)		10.3		

WEIGHT POUNDS	WEIGHT GRAMS	NUMBER OF BIRDS																														
		1	2	3	4	5	6	7	8	9	10	11	12	13	14	15	16	17	18	19	20	21	22	23	24	25	26	27	28	29	30	
0.00	0.00																															
0.04	0.20																															
0.09	0.40																															
0.13	0.60																															
0.18	0.80																															
0.22	100																															
0.26	120																															
0.31	140																															
0.35	160																															
0.40	180																															
0.44	200																															
0.49	220																															
0.53	240																															
0.57	260																															
0.62	280																															
0.66	300																															
0.71	320																															
0.75	340	x	x	x	x	x																										
0.79	360	x	x	x	x	x	x	x	x	x	x																					
0.84	380	x	x	x	x	x	x	x	x	x	x	x	x	x																		
0.88	400	x	x	x	x	x	x	x	x	x	x	x	x																			
0.93	420	x	x	x	x	x	x	x	x	x	x	x	x	x	x	x	x	x	x													
0.97	440	x	x	x	x	x	x	x	x	x	x	x	x	x	x	x	x	x	x	x	x	x	x	x	x	x	x	x	x	x		
1.01	460	x	x	x	x	x	x	x	x	x	x	x	x	x	x	x	x	x	x	x	x	x	x	x	x	x	x	x	x	x		
1.06	480	x	x	x	x	x	x	x	x	x	x	x	x	x	x	x	x	x	x	x	x	x	x	x	x	x	x	x	x	x		
1.10	500	x	x	x	x	x	x	x	x	x	x	x	x	x	x	x	x	x	x	x	x	x	x	x	x	x	x	x	x	x		
1.15	520	x	x	x	x	x	x	x	x	x	x	x	x	x	x	x	x	x	x	x	x	x	x	x	x	x	x	x	x	x		
1.19	540	x	x	x	x	x	x	x	x	x	x	x	x	x																		
1.23	560	x	x	x	x	x	x	x	x	x	x	x	x																			
1.28	580	x	x	x	x	x	x	x																								
1.32	600																															
1.37	620																															
1.41	640																															
1.46	660																															
1.50	680																															
1.54	700																															
1.59	720																															
1.63	740																															
1.68	760																															
1.72	780																															
1.76	800																															
1.81	820																															
1.85	840																															
1.90	860																															
1.94	880																															

Section 4

$$CV\% = \frac{\text{Range of Weights} \times 100}{\text{Average of Weights} \times F. \text{ Value}}$$

Range is defined as the difference in weight between the heaviest and lightest birds. The appropriate F value depends on sample size. Examples are as follows:

Sample Size	F. Value	Sample Size	F. Value
10	3.08	60	4.64
15	3.54	65	4.70
20	3.73	70	4.76
25	3.94	75	4.81
30	4.09	80	4.87
35	4.20	85	4.90
40	4.30	90	4.94
45	4.40	95	4.98
50	4.50	100	5.02
55	4.57	105	5.03

Average Weight of populations	Metric	464	Imperial	1.02
Body Weight Range	Metric	240	Imperial	0.53
CV% =	$\frac{240 \times 100}{464 \times 5.03}$	10.3	$\frac{0.53 \times 100}{1.02 \times 5.03}$	10.3
Flock Details:				
Age		28		28
Average Weight		464		1.02
Total Birds Weighed		212		212

After weighing, the following parameters can be calculated for the flock:

- Average weight
- Weight range (highest body weight – lowest body weight)
- Coefficient of variation (CV %)

Average body weight and CV% should be plotted on a body weight for age graph and compared to target. An example of such a chart is given in **Figure 77**. Variation from performance targets will help to determine future feed allocations.

Figure 77: Example of a chart for weekly recorded pen body weight and CV% compared with performance standards. In this example, body weight is on target and CV% is good, feed increases should follow recommendations.

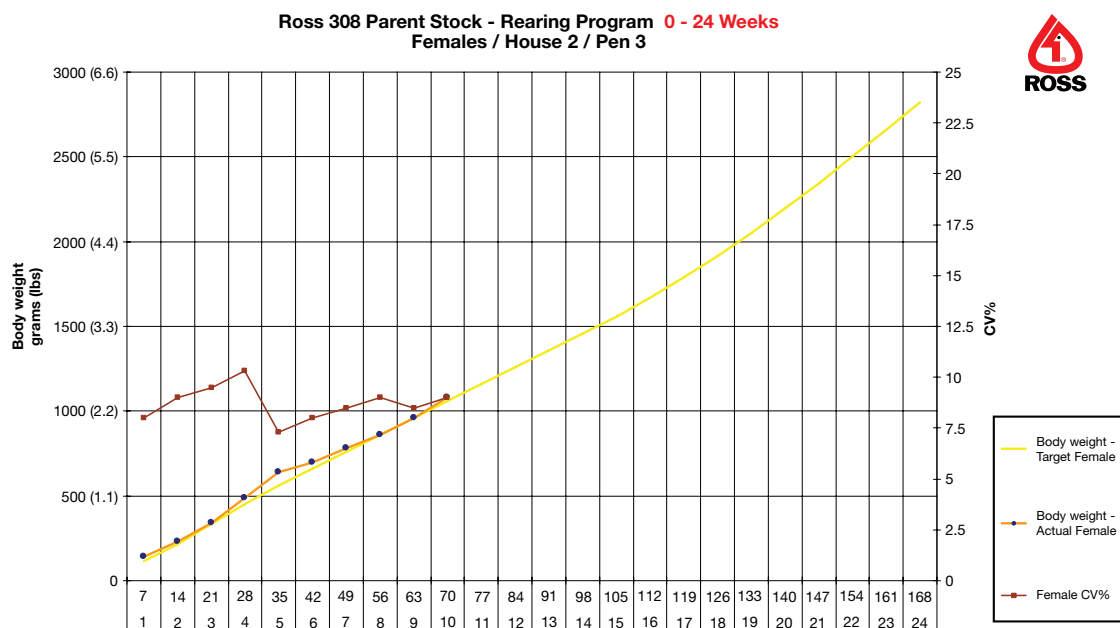

Procedures for Electronic Scales

If electronic scales are used the population statistics (average weight, weight range, and CV%) are automatically calculated and given on the print-out (**Figure 74**). As with manual scales the average body weight and CV figures should be plotted on a body weight for age graph and compared to targets. Establishing variation from target will help determine future feed allocations.

Notes on Sample Weighing of Males

It is important to maintain male body weight and physical condition after mating-up, but accurate monitoring of body weight can be more difficult at this time. False variation in bird weight over time may arise because of the difficulty in catching representative samples of males. So it is crucial that a good male sample size (male sample size should be increased to a minimum of 10% of the population from mating-up), from different locations in the house, is weighed during lay.

Where an automatic (jump-on platform) weighing scale is set up in a house, male body weights must still be measured by hand weighing using either manual or electronic scales. This is to verify the accuracy of the automatic system. Male sample sizes for these systems can tend to be unrepresentative, because as males increase in size they become less likely to use these platforms. Hand weighing (which should be completed weekly from point of lay as a matter of course) also provides opportunity to check the physical condition of the males.

Note on Sample Weighing of Females

Where automatic (jump-on platform) weigh scales are used and the female weights from these indicate an unexpected variation or deviation from the expected target, a sample of birds should be reweighed by hand weighing. If the variation is confirmed the platform scales should be recalibrated to check they are working correctly. Additional hand weighing of females is only required in such situations and not routinely, as with males.

Inconsistent Weight Data

If a sample weighing produces data that is inconsistent with the previous weights or expected gains, a second sample of birds should be weighed immediately as a check before any decisions on feed allowances are made. This will identify potential problems (e.g. improper sampling procedure, feed allowance errors, drinker failures, or disease) which may need to be rectified.

KEY POINTS

- Growth and development in a flock are assessed and managed by weighing representative samples of birds and comparing them with target weight for age.
- Sample weighing should start at day-old and continue at least weekly.
- Individual bird weights should be taken from 14-21 days of age for calculation of CV%.
- A minimum of 50 birds or 2% of the female population (10% of the male population) should be weighed but all birds caught in the sample must be weighed.
- Weigh birds at the same time each week using the same set of scales.
- Scale accuracy should be checked regularly.
- Record and plot average body weight and CV% on a body weight-for-age chart.
- If sample weighing produces data inconsistent with previous weights or expected gains weigh a second sample immediately.

Section 5 - Assessment of Bird Physical Condition

Assessment of Bird Physical Condition

Objective

To ensure persistency of fertility and egg production by achieving optimum physical condition of males and females.

Principles

Regular physical assessment of birds provides additional information for guidance on required adjustments in management practices to ensure persistency of reproductive performance.

The physical assessment of birds within a flock involves monitoring a number of factors (including body weight, body condition (breast shape and degree of fleshing), and skeletal frame size) to get a good overall view of bird condition, health, and reproductive potential.

Assessing Bird Condition

Assessments of bird condition (e.g. fleshing, legs and feet) should be completed, at least weekly, from placement through to depletion. This should be done as part of the routine flock management procedures, and will help to develop good stockmanship techniques in farm personnel. From these regular assessments, an awareness of what birds should both look and feel like at any given age can be developed. This will support management decisions and help recognize and solve problems. There are 2 opportunities to assess the flock - when birds are being weighed, or when doing a house 'walk through'.

It is important that the flock is maintained in optimal condition throughout its life. However, it should be recognized that the optimum will vary slightly at different times during the production cycle, depending on, for example, whether or not the flock is approaching sexual maturity, is at peak production, or is established in lay. At any point in time, an inadequate (under-fleshed or thin), or excessive (over-fleshed or fat) condition will have a negative impact on flock performance and should be avoided. Particular attention to bird condition should be paid:

- In the period leading up to the start of egg production (19-24 weeks of age) for females.
- Throughout lay for males when a male reduction plan is being followed.

Weighing provides the ideal opportunity to assess bird physical condition. As a general rule, a minimum of 50 birds or 2% of the population (whichever is the greater) should be sampled for females and a minimum of 10% of the population should be sampled for males (for more information see the section on Monitoring Broiler Breeder Growth). Physical condition should be routinely assessed and recorded on all birds sampled for weighing.

In addition, it is good management practice to 'walk through' the flock at least once a week, picking up a selection of individual birds to assess their physical condition. As a guide, a minimum of 20-30 females and 15 males should be selected at random, and their physical condition assessed.

KEY POINTS

- Regular assessments of physical condition should be made throughout the life of the flock.
- Using a combination of physical assessments will provide a better indication of bird condition and fitness-for-purpose and thus facilitate better management decisions (feeding allocation and implementation of male number reduction plans).
- A representative sample of the population should be assessed at least weekly during weighing to determine overall flock condition, but individual birds should also be assessed. It is good practice to catch and physically assess individual birds while doing a house “walk through”.

Assessment of Male Condition

Males that are in good physical condition will have good fertility. Completing routine physical assessments of male condition throughout the life of the flock will help ensure that optimum fertility is achieved.

Any personnel handling birds should do so with due care and attention, and must be appropriately trained.

Rear

During rear, it is important that birds achieve target body weight and that the flock is uniform in its development. Skeletal frame size and shank length can be a useful means of visually comparing male development and are supportive management tools. Up to 63 days (9 weeks) of age there is a positive relationship between body weight, frame size, and shank length (**Figure 78**). In general, birds that achieve the recommended body-weight target during rear will also achieve good uniform development of the shank and frame (skeleton). Observing birds feeding at the feed track and/or at nipple or bell drinkers, and looking at the variation in shank length provides an opportunity to see if there is a high level of variability within a population (suggesting poor uniformity), the reasons for this variability should be investigated (e.g. poor feed distribution, inadequate feeder space, health issues).

Figure 78: Shank length in males. The male on the left has poorer development of the shank in both length and diameter.



Birds that follow the recommended body-weight profile in rear should also achieve a body condition that is acceptable. However, regular and routine monitoring of male fleshing in conjunction with measurement of body weight can provide a more accurate indicator of overall body condition, and establish more appropriate management and feeding strategies. To achieve this, males should be handled regularly (at least weekly during weighing) from placement, paying particular attention between 15 weeks of age and the start of production, in preparation for sexual maturity. It is also important to be aware of general health, alertness and activity.

Lay

Physical assessment of male condition for removing males as part of a male reduction plan
 A planned mating ratio reduction program (**Table 16**) should be followed to maintain persistency of fertility. The optimum mating ratio is maintained by removing males from the flock that are in poor physical condition and not working.

Table 16: A guide to typical mating ratios as a flock ages.

Days	Weeks	Number of Good Quality Males/100 Females
154-168	22-24	9.50-10.00
168-210	24-30	9.00-10.00
210-245	30-35	8.50-9.75
245-280	35-40	8.00-9.50
280-350	40-50	7.50-9.25
350 to depletion	50 to depletion	7.00-9.00

Assessment of male condition for managing mating ratios should be routinely made during weighing, but can also be done on individual males when ‘walking’ through the flock.

Physical assessment of male condition must be comprehensive and include:

- Alertness and activity.
- Body condition (fleshing) - shape and softness or hardness of breast muscle tone.
- Legs and feet - the legs should be straight with no bent toes, and the footpads should be free from abrasions.
- Head - males should have a uniform, intense red color around the comb, wattle, and eye area. Beaks should be uniform in shape.
- Feathering - a good quality male will exhibit some partial feather loss, especially around the shoulders and thighs.
- Vent - should show some feather wear, be large and moist, with good (red) coloration.
- Body weight - according to target.

Alertness and activity

The flock should be observed throughout the day to monitor mating activity, feeding, resting location, daytime distribution, and distribution immediately prior to lights out. Males should be alert and active, and evenly distributed over the litter (scratch) area for most of the light period (**Figure 79**). They should not be concentrated on the slats, or hiding under equipment. Males identified as not being alert and active should be removed. If the mating activity of the flock is observed to be lower than expected, the reason for this should be investigated (e.g. poor male condition, sexual maturity between males and females not synchronized, inadequate feed distribution, and male feed allocation).

Figure 79: Good distribution of alert males within a flock.



Monitoring body condition (breast shape or fleshing) in males

Breast shape or fleshing is a good indicator of bird condition and is particularly useful for males. Birds that are over- or under-fleshed are more likely to have problems with mating and fertility at some point. Traditionally, body weight has been the main driver for male broiler breeder management decisions, but using body weight alone can be misleading. For example, it is possible to have 2 birds of the same age and body weight that differ in physical appearance and body condition (one could be skeletally smaller or larger, and fatter or leaner - **Figure 80**), such birds would require different management, namely feed levels and timing, to achieve good levels of fertility.

Figure 80: An example of 2 adult male birds of the same weight and age but differing body condition. The bird on the left is shorter and fatter, and the bird on the right taller and leaner, but the body weight of the 2 birds is equal.

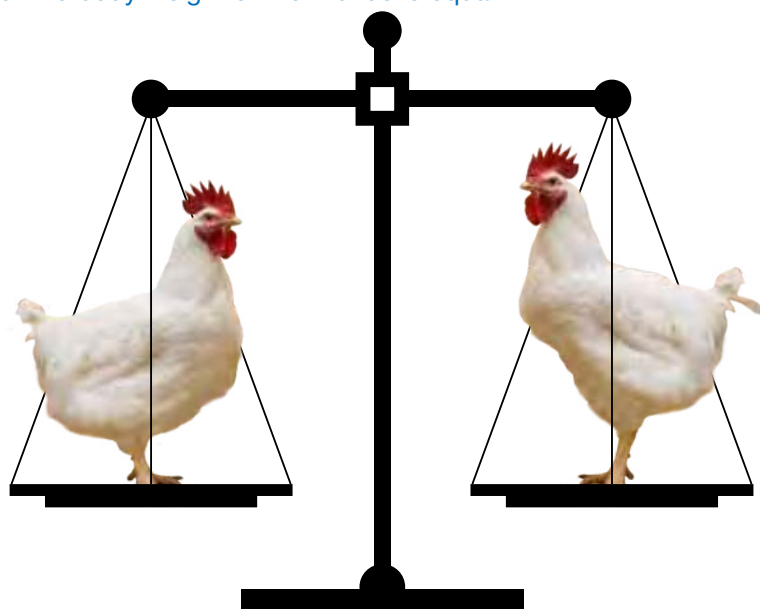

Observing and awareness of male condition is important throughout the bird's entire life. Achieving the optimum condition, maintaining it, and ensuring that there is no deterioration in it at any stage is key to male performance. However, particular attention is recommended:

- At the onset of physical mating activity to ensure that early flock fertility and productivity are maximized.
- Post-peak to optimize lifetime flock fertility.

Body condition scoring system

Body condition (fleshing) should be assessed on a scale of 1 to 3. A score of 1 being under-fleshed, a score of 2 being ideally fleshed, and a score of 3 being over-fleshed. The differences between the 3 scores are illustrated in **Figure 82**. The images in **Figure 82** were taken using a CT (Computed Tomography) x-ray scanner (**Figure 81**), which allows the bird 'behind' the feathers to be viewed.

Figure 81: CT scanner used to take images that illustrate a scoring system to assess bird body condition (fleshing).



Figure 82: CT scanner images illustrating the fleshing scoring system for assessing bird condition. These pictures show 40 week old males. The top 3 images show the whole bird (the dotted lines indicate the position at which the cross section images were taken). The bottom 3 images show an internal cross section view of the breast.

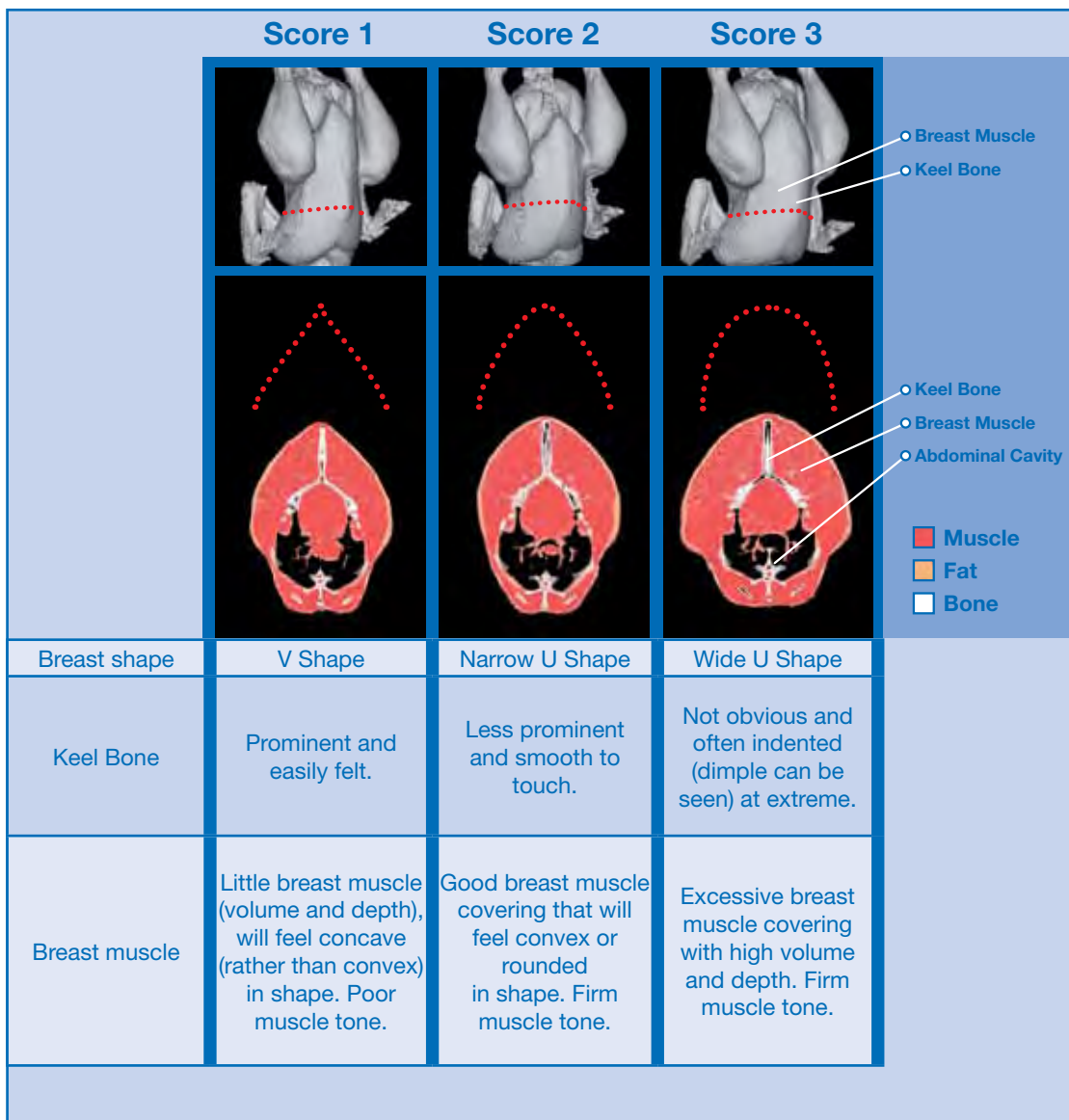

Procedure for assessing body condition (breast shape or fleshing)

Breast shape and fleshing should be assessed at least once a week during weighing. All birds being sampled weighed should be assessed.

To assess fleshing, run the hand along the length of the breast (over the keel bone), feeling the shape, volume, and tone of the breast muscle (**Figure 83**).

A score of 1, 2 or 3 indicating the amount and shape of breast should be given to each bird. Scores should be recorded, and the average score for the flock determined each week. The trend in bird condition over time should also be monitored.

Figure 83: Assessing male condition. While holding the bird by both legs, the hand is run over the keel bone, and the prominence of the keel bone, and the amount, shape, and firmness of the breast on either side of the keel assessed. The male in the picture is 26 weeks old and the keel bone should be easily felt (but not prominent). The breast should be firm and rounded to touch, filling the space on either side of the keel bone (condition score 2).



Body condition scores should be taken into consideration, along with body weight and uniformity, to provide the basis for appropriate adjustments in bird management. Examples of how body condition assessments might be used in this way are given in **Table 17**.

Table 17: Examples of how male condition can be used in conjunction with body weight to determine appropriate flock management strategies.

	Flock Age	Average Body Weight	Average Condition Score Week 38*	Average Condition Score Week 39*	Average Condition Score Week 40*	Management Strategy
Sample 1	40 weeks	Target	2.0	2.0	2.2	Body weight on target, condition good. Give recommended feed increase.
Sample 2	40 weeks	Target	2.0	1.9	1.8	Body weight on target but condition score falling. Consider giving additional feed increase above recommendation, and investigate reason for declining condition.
Sample 3	40 weeks	200 g (0.4 lbs) below target	1.9	1.8	1.4	Body weight below target, condition score low (birds thin). Check condition score is correct. If confirmed, give additional feed increase. Investigate feed volumes, uniformity of feed distribution, and effectiveness of separate-sex feeding.
Sample 4	40 weeks	200 g (0.4 lbs) above target	2.0	2.2	2.5	Body weight over target and condition score high (birds fat). Verify that feed distribution and separate-sex feeding systems are working optimally. Feed to maintain increased body weight.

* Average condition score corresponds to group of males sample weighed.

The assessment of body condition score will differ slightly between individuals. Ideally, body condition should be assessed by the same person each week. In addition, while the average condition score for the males in a flock is ‘2’, the optimum condition score for individual flocks may vary slightly around the ideal.

KEY POINTS

- Body condition (fleshing) should be assessed at least weekly during weighing.
- All birds being weighed should be assessed and their condition given a score of 1, 2 or 3 (1 being under-fleshed, 2 being ideal and 3 being over-fleshed).
- Condition scores should be recorded and the average for the flock calculated. The trend over time should also be monitored.
- Use body condition in conjunction with body weight and uniformity to determine appropriate management and feeding strategies.

Legs and feet

To maintain high fertility levels within a flock, males must have good feet and legs (**Figure 84**). Legs should be straight with no bent toes. The footpads should be clean and free from physical damage. Abrasions and cracks on the feet may lead to infection and discomfort that will reduce welfare and mating activity. Any male showing poor feet and leg condition should be removed from the flock.

Figure 84: Good leg health in males.



Head

Males in good condition that are working well will have a uniform, intense red color around the comb, wattle, and eye area (**Figure 85**). Under normal conditions, the face of a healthy, well conditioned male will redden up from the face in towards the eye. Conversely, the face of a male in poorer condition will start to loose color from the eye outwards. Males with low face color may have a low mating activity, and should be considered for removal.

Figure 85: A healthy, active male showing a red face and comb (on the left), and a male in poorer condition, showing paleness around the eye (on the right).



Feathering

In production, a good quality male that is working well will exhibit some partial feather loss, especially around the shoulders, thighs, breast, and tail (**Figure 86**). Well feathered males generally have low mating activity, and should be considered for removal.

Figure 86: An active male showing some feather wear (on the left), and an inactive male showing no feather wear (on the right).



Vent (cloaca) condition

During weekly weighing, male vent condition should be assessed. Assessing the intensity of redness and moistness of the vent (**Figure 87**) is a useful management tool for assessing male condition and mating activity within the flock. Healthy, well-conditioned males working at optimum rates will demonstrate a redder vent color. The vent will be moist, and there will be some feather loss around the vent area. Males of poor condition with low mating activity will have pale vent color. The vent will be small and dry with good feather color. The aim is to maintain a uniform high coloration of the vent within the flock.

Figure 87: Variation in vent color used to indicate degree of mating activity in males. The vent on the left is from a working male and has a good red color, is moist and shows some sign of feather wear. The vent on the right is pale in color, small, dry, and shows no sign of feather wear.

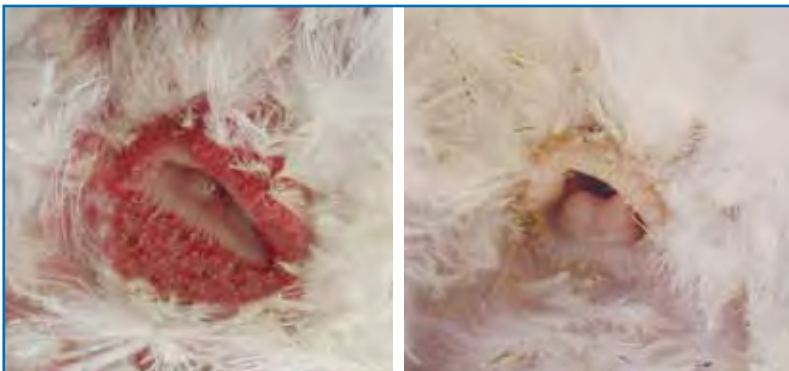

KEY POINTS

- During lay, a male reduction plan must be followed to maintain optimal flock fertility.
- The decision about which males should be removed from the flock is based upon a general assessment of male physical condition.
- Attributes that should be looked at include:
 - Body weight.
 - Body condition.
 - Legs and feet.
 - Face color.
 - Vent condition.
 - Alertness and activity.

Assessment of Female Condition

The weekly sample weighing also provides an ideal opportunity to assess female physical condition. As with males, it is good management practice to pick up and assess the condition of individual females while walking through the flock.

Any personnel handling birds should do so with due care and attention, and must be appropriately trained.

Rear

In rear, assessment of bird physical condition is based primarily on body-weight monitoring and skeletal size (skeletal frame size and shank length). However, it is also important to be aware of degree of fleshing, general health, alertness, and activity. Achieving uniform growth and development of the females during rear is key to subsequent laying performance. Variation in frame size within the female population can provide a visual indicator of poor flock uniformity (determination of body weight CV% should be used to confirm this). When poor flock uniformity occurs, the cause(s) should be identified (e.g. poor feed distribution, inadequate feeder space, disease).

Lay

During lay, the main drivers for decisions on feeding management for females are body weight, egg production, and egg weight. Regular monitoring of pin bone spacing, fleshing, and fat pad development can provide useful supportive management information.

Pin bone spacing

Measurement of the spacing between the pin (pelvic) bones is a useful management tool for determining the stage of sexual development in growing females, and hence, when lay is about to commence. Under normal conditions, the spacing between the pin bones will gradually increase as the bird ages until it becomes maximal at point of lay (**Table 18**). If pin bone spacing does not develop as indicated in **Table 18** (i.e. is below 1 ½ fingers at the intended age of light stimulation), or if there is a big variation in pin bone spacing within the flock, then light stimulation should be delayed.

Table 18: Changes in pin bone spacing with age.

Age	Pin Bone Spacing
84-91 days	Closed
119 days	One finger
21 days before first egg	1½ fingers
10 days before first egg	2-2½ fingers
Point of lay	3 fingers

Pin bone spacing should be monitored regularly from 15 to 16 weeks (105 to 112 days) of age up to point of lay (**Figure 88**). Ideally this should be done every time the house is 'walked', but at a minimum it should be done weekly. The term 'finger' is relative to the operator's hand size and so will vary from person to person. Ideally, it should be the same person who measures pin bone spacing from week to week. As a general rule, birds are at the point of lay when the distance between the pin bones is about 3 fingers (or approximately 5-6 cm [2-2.5 in]).

Figure 88: Assessment of pin bone spacing in females.

Monitoring body condition in females

In general, a uniform flock of females achieving the target body-weight profile in rear should also achieve an acceptable body condition.

It is important to ensure that females do not become either over- or under-fleshed. Regardless of age, females that are substantially over-fleshed are likely to be heavy, and have increased fat deposits, while under-fleshed females are likely to be in poor condition. Both situations impact lifetime reproductive performance. As is the case for males, a sample of females should be handled frequently (at least weekly), and body condition (fleshing) assessed to ensure that the flock remains in good health and condition to maintain reproductive performance.

The same scoring system used for males should be used for females (**Figure 89**). However, the way in which the flock results are interpreted and used are different, as the female body shape differs to that of males, and it is not recommended to remove individual females from a flock based on this assessment. For females, it is critical to achieve target body weights, and modify feed allocation appropriately to egg production levels, and egg weight. Fleshing assessment in females tends to be a supportive management tool (rather than pivotal; as is the case for the males in lay).

In rear, the appropriate flock management should minimize the incidence of score 1 (under-fleshed) and score 3 (over-fleshed) birds in the flock.

In lay, it is preferable that the average flock score is between 2.0 to 2.5, and that the occurrence of score 1 females is minimized because under-fleshed females are likely to have lower egg outputs. However, a body condition score 3 can be satisfactory for females in lay, as a fleshy female can still have a good reproductive output.

Figure 89: CT scanner images illustrating the fleshing scoring system for assessing bird condition. These pictures show 40 week old females. The top 3 images show the whole bird (the dotted lines indicate the position at which the cross section images were taken). The bottom 3 images show an internal cross section view of the breast.

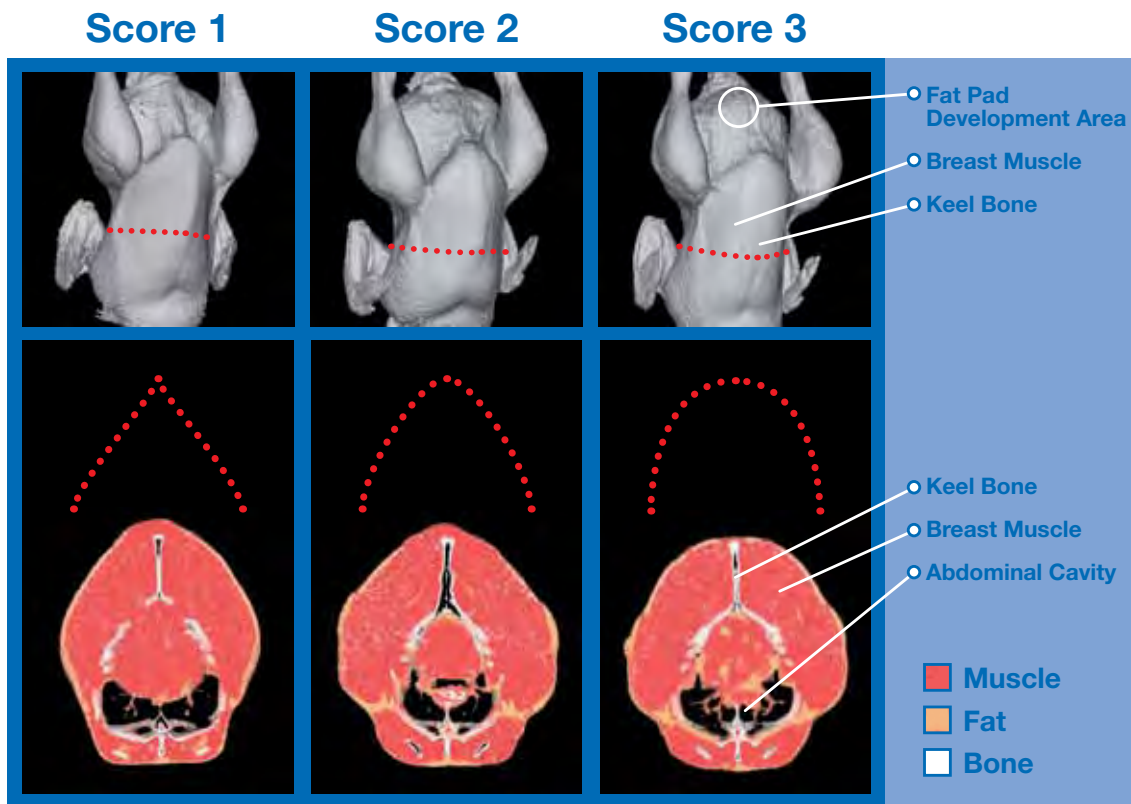

Abdominal fat pad

In lay, monitoring fat pad deposition (**Figure 90**) is another supportive management tool that can help provide a better overall assessment of bird condition.

Figure 90: Assessing abdominal fat pad in a female broiler breeder. To assess abdominal fat pad content, gently feel the area just below the cloaca with a cupped hand. Post-peak abdominal fat pad should not exceed the level shown here.



There is little fat pad development in properly fleshed broiler breeders prior to onset of lay. Significant development of the fat pad generally occurs after sexual maturity is attained, with the fat pad reaching its maximum size about 2 weeks before peak egg production. The abdominal fat pad in females can provide an energy reserve to support maximum egg production, but any excess fat, particularly after peak, will be detrimental to persistency of egg production, fertility, and hatchability, and it may reduce liveability. A positive relationship exists between body weight and fat pad development so heavier females are likely to have increased fat levels which may affect productivity (**Figure 91**).

Figure 91: Increases in fat pad with weight. The pictures show a longitudinal cross section (cloaca on left, head [not shown] on right) of 3 females. The birds were 40 weeks of age. The female on the left is losing condition, and is below target weight with little fat. Egg production in such a bird is likely to be reduced or even cease. The bird on the right has a large fat pad, and shows fat accumulations around the internal organs. Rate and persistency of lay are likely to be reduced in this bird.

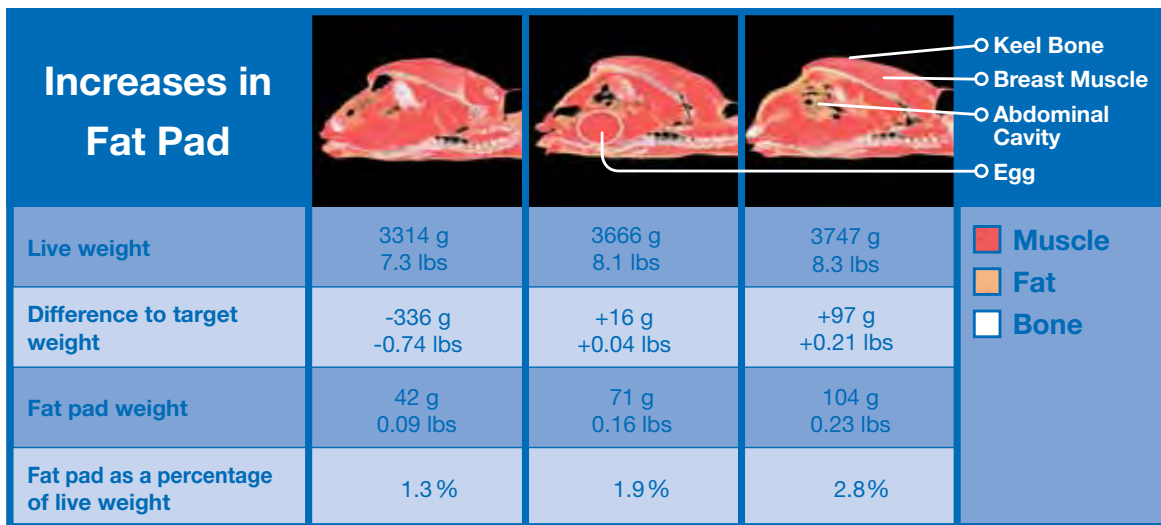

From the start of lay, females should be routinely (at least weekly) assessed to monitor the progress of fat pad development. The actual degree of fat pad deposition will vary from bird to bird. The objective after peak production is to maintain the female at physical mature weight, but to minimize the development of excess fat pad. As a guide, maximum fat pad volume should be no more than the size of an average person’s cupped hand or a large egg (roughly 8-10 cm [3-4 in]).

KEY POINTS

- Regular assessments of female physical condition (fleshing) should be made throughout the life of the flock.
- Using a combination of physical assessments (body weight, fleshing, fat pad, and pin bone spacing) provides a reliable indication of overall female condition upon which appropriate management decisions can be based.

Section 6 - Care of Hatching Eggs on Farm

Care of Hatching Eggs

Objective

To keep the embryo and egg contents in the best possible condition for good hatchability and chick quality.

Principles

Eggs must be kept in clean conditions, and at the correct temperature and humidity to achieve the best hatchability. To achieve this, satisfactory procedures for collection, disinfection, cooling, storage, and incubation of the eggs should be in place, and each process should be carried out so that embryonic development is not compromised.

Why Do Hatching Eggs Need Care?

Fertilization takes place at the top of the oviduct shortly after the yolk is released from the ovary. The yolk then passes down the oviduct (**Figure 92**). As it does so, the outer layers of the egg are laid down, and the fertilized germinal disc grows and develops. By the time the egg is laid, it contains a germinal disc that has been growing for 24 hours as the egg is formed around it (**Figure 93**).

Figure 92: A diagram showing the ovary and oviduct. Key events are labeled.

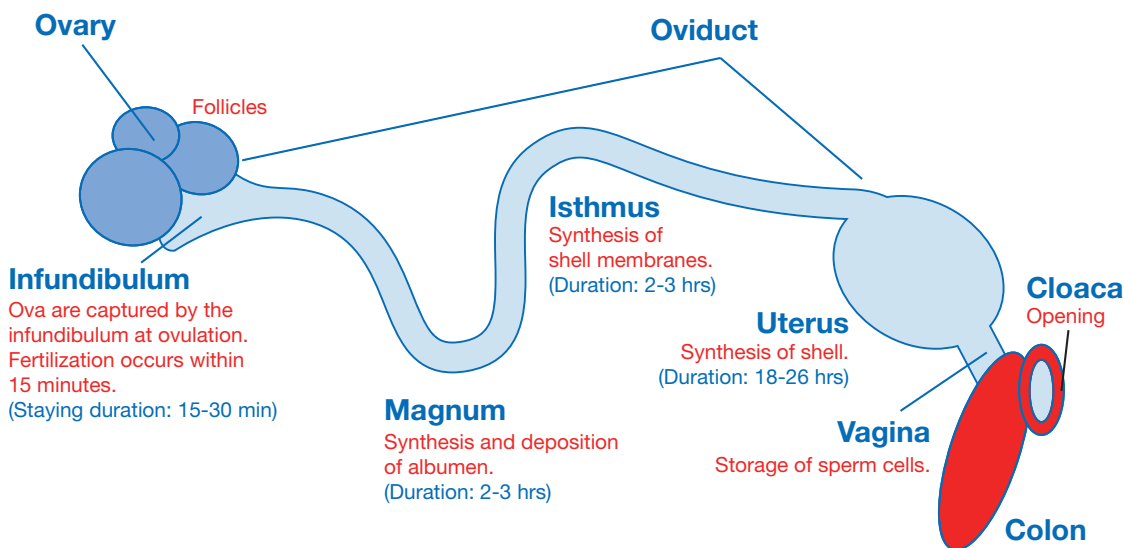

After the egg is laid it must be cooled to stop any further development until the egg is set at the hatchery. The care given to hatching eggs has to meet the needs of these dormant (but living) embryos. The egg components surrounding them have to be maintained in good condition. Fluctuating egg store temperatures can cause stop-start growth of the germinal disc which will reduce hatchability. (However, recent studies have shown that if eggs are to be stored for more than a week, it can be beneficial to warm them up to incubation temperature in a setter for short periods during storage.)

The Egg's Protection System

The egg provides a multi-layered system of protection from microbial contamination (**Figure 93**). The cuticle, egg shell, shell membranes, and some of the proteins in the albumen act as either physical or chemical barriers to prevent microbes gaining access to, and growing in, the egg contents.

Figure 93: Internal structure of a fertile egg at the time of lay.

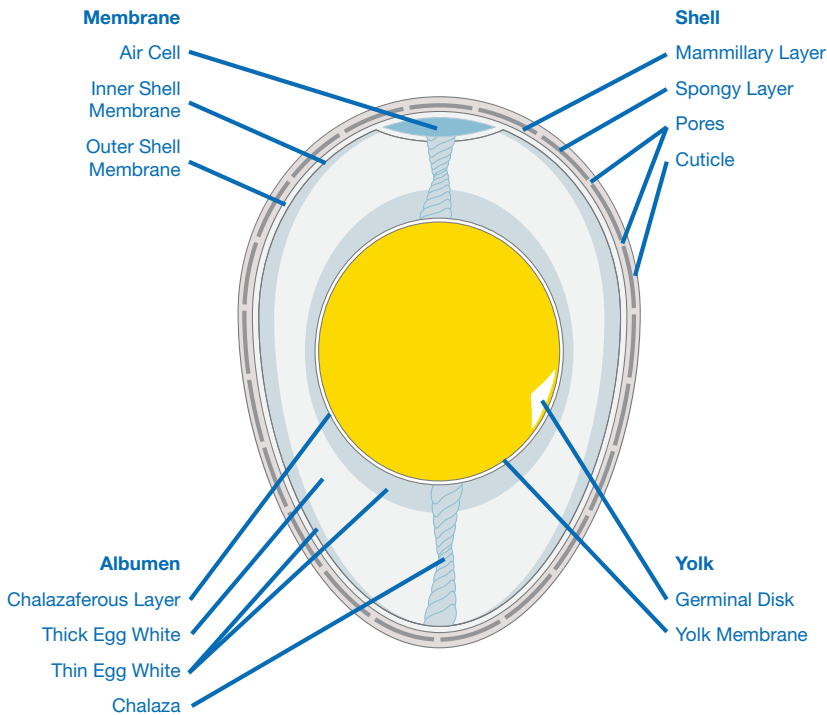

The shell of the egg is a porous structure. Pores run from the surface right through the shell (**Figure 94**). These pores are needed to allow oxygen into, and water and CO₂ out of, the egg as the embryo develops.

Figure 94: Cross section showing the structure of the eggshell.

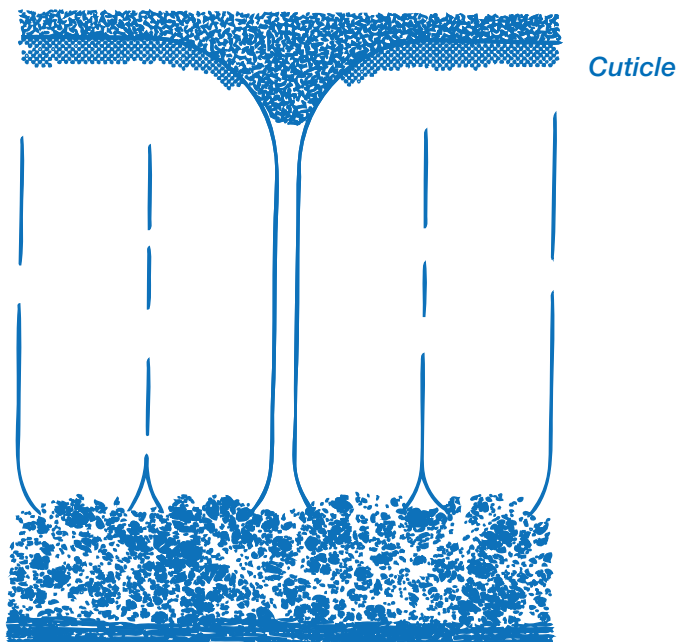

The entrance to the pore on the egg shell surface is protected by the cuticle. The cuticle is a thin protein coat which allows gases, but not micro-organisms, through. This provides the egg contents with some protection from microbial penetration. However, the cuticle does have one point of weakness - immediately after the egg is laid it is still not completely formed (this is why the shell surface looks wet and under magnification it has an open, sponge-like appearance). The cuticle hardens to a flatter, flake-like surface within 2-3 minutes of the egg being laid. Until this process is complete it is easy for microbes to penetrate the cuticle, and then pass down the pores and into the egg (**Figure 95**).

Figure 95: Example of bacterial penetration that can occur immediately after laying through the pores of dirty egg shells.



The photograph shows the inner egg shell surface of a soiled egg. The egg contents were removed through a small hole at the small end, replaced with a nutrient gel and incubated. Bacterial colonies show up in red.

Understanding the structure of the egg shell helps to explain why certain procedures used on farm to 'clean' eggs can make contamination problems worse. For example, if slightly soiled eggs are buffed or scraped to remove the surface dirt from the shell, some of the dust that this produces will be packed into the shell pores and block them. Blocked pores will impair gas exchange, and as a result, limit the oxygen available to the developing embryo.

Contamination problems can also be made worse if the eggs become wet after collection for any reason. Liquid will run into the pores of the shell, carrying any bacteria on the shell surface with it. This is especially likely to happen if the egg contents are cooling. Cooling creates a partial vacuum within the shell, making it more likely that any surface liquid (and microbes) will be drawn in through the pores and is the reason why condensation on the egg shell causes so many problems.

KEY POINTS

- Eggs should be maintained in a clean state between lay and packing.
- Methods used to remove surface dirt should be gentle so as not damage the cuticle, or block the egg shell pores.
- Condensation on the egg surface should be avoided as it can lead to contamination problems.

Best Practice for Care of Hatching Eggs

Egg collection

- Manage the flock to minimize the number of eggs laid on the floor (see section on Management into Lay).
- Keep the insides of the nests and any collection belts free of litter and droppings.
- Collect nest eggs a minimum of 4 times a day, adjusting the exact timings so that no more than 30% of the eggs fall in any one collection (any more will increase the incidence of dirty or cracked eggs). The majority of the eggs will be laid in the morning and collection intervals should be managed accordingly. The nests and egg collection belt should be cleared at the end of the working day to minimize the number of eggs left over night.
- Collect floor eggs separately. They should be collected as often as possible (more often than nest eggs) and should be kept separately from nest eggs so that the hatchery can manage appropriately the contamination risk they present.
- Monitor the numbers of floor and dirty eggs, and adjust management factors to minimize them (see section on Management into Lay).

Egg packing and selection

- Select and pack the eggs immediately after each collection.
- Reject small eggs (minimum weight will be an economic decision), cracked or damaged eggs, eggs with gross shell abnormalities, double-yolk eggs, soft shelled eggs, and any eggs which are more than 25% covered with dirt or droppings. Record numbers rejected in each category and monitor them.
- Avoid wet egg disinfection methods – fumigation with formaldehyde is better.
- If eggs do become wet, let them dry before fumigating them or placing them in a cold egg store.
- Immediately after each tray of eggs is packed, place it in a rack in the egg store. Trolleys should be packed from the bottom up. This will avoid re-warming cooled eggs by placing warmer eggs beneath them in the trolley (**Figure 96**).
- Once an egg trolley has been placed in the egg store it should stay there – a partial trolley should be filled by taking trays of eggs into the store to finish loading not by taking the trolley out of the store.
- If eggs are to be boxed, they should be cooled to egg store temperature prior to boxing.
- Eggs or trolleys should not be wrapped in plastic until they have cooled to egg store temperature.

Figure 96: Hatching eggs incorrectly stored in a trolley.

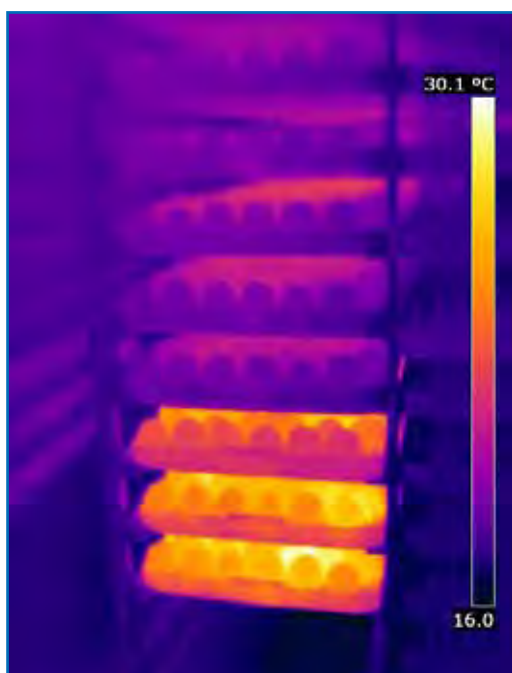

*The thermal image shows freshly collected, warm eggs being placed below already cool eggs collected earlier. **This is not good practice. Trolleys should always be filled from the bottom so that fresh eggs are stored above cooled eggs.***

Egg disinfection

Fumigation with formaldehyde remains the most effective (and preferred) method for disinfecting the shell surfaces of hatching eggs. Provided fumigation is performed correctly, it achieves excellent kill rates of micro-organisms on the shell surface without wetting the shell, damaging the cuticle, or damaging the embryo inside the egg. Despite this, some countries now prohibit the use of formaldehyde because of the potential risk to human health and safety if it is not used correctly.

Many different chemicals and application methods have been investigated as alternatives to formaldehyde fumigation. None have proved to be as effective, either because they kill a more limited range of micro-organisms, because they have to be used in solution, because they damage the cuticle, or because they are detrimental to embryo survival.

- Formaldehyde fumigation should always be carried out using the appropriate safety precautions. Local rules governing the health and safety of farm workers must be always adhered to when using formaldehyde.
- Fumigate eggs with formaldehyde at least once before they leave the farm.
- Make sure that the eggs are well separated on plastic egg – cardboard tends to absorb the gas.
- Ensure the fumigation room is well sealed during fumigation and allow at least 20 minutes for the gas to circulate after it has been generated.
- Heat a) 10 g (0.4 oz) paraformaldehyde prills OR b) a mixture of 43 ml formalin (37.5%) and 21 g (0.7 oz) potassium permanganate per m³ of fumigation room.
- Ensure room temperature is a minimum of 24°C (75.2°F) and humidity a minimum of 65% RH.
- Run a circulating fan during fumigation to help circulate the fumigant gas between the eggs.
- Make sure that all the gas is completely exhausted from the room before workers re-enter to move the eggs. This should be re-checked periodically using an appropriate meter.

Assessing alternatives to formaldehyde

Where formaldehyde fumigation is not permitted due to local health and safety regulations, alternative methods of disinfection need to be found. Many alternatives to formaldehyde have been tested over the years. All have disadvantages, and most have to be used with the same due care and attention as formaldehyde.

There are many products sold as being suitable for disinfecting hatching eggs (including hydrogen peroxide, peracetic acid, quaternary ammonium and chlorine disinfectants). Before implementing any new method or chemical for disinfecting hatching eggs it is strongly advised that their effectiveness is thoroughly tested, making sure to closely follow the advice of the equipment and chemical suppliers.

Factors to consider when testing alternatives to formaldehyde include:

- The egg shell bacterial counts before and after treatment.
- Egg content bacterial counts after treatment.
- Impact on cuticle cover (which can be seen under UV light).
- Hatchability.

Hatchability tests should involve at least 1,000 eggs per treatment group, split from a single collection of eggs. Half the eggs should be treated according to current methods, and the other half by the proposed new treatment. Ideally, the test should be repeated over a range of flock ages and egg storage durations.

Cleaning soiled eggs

Provided any surface dirt is not extensive, it can be removed by gently flicking the dirt off with a finger nail, or for soft droppings, by gently wiping off with a clean paper towel. Care should be taken not to contaminate clean parts of the egg. The eggs should then be disinfected (ideally by fumigation with formaldehyde) and sent to the hatchery clearly marked as dirty.

The washing of hatching eggs is not good practice. But under some conditions, washing eggs may be unavoidable. If washing eggs is necessary, the following applies:

- Use a washer which sprays the eggs with warmed disinfectant solution, rather than one which relies on the eggs being immersed in the solution.
- Wash water should be 41°C (106°F) – this will ensure that the wash water is always warmer than the warmest eggs in the collection (**Figure 97**).
- The process should be recorded and monitored, taking care to monitor temperatures and the frequency with which the washing water is changed.
- Make sure that the disinfectant concentration does not fall below the recommended minimum effective concentration level and that the washer solutions are regularly replaced to maintain disinfection concentration.
- Allow the eggs to dry before they are cooled in the egg store.
- Washed eggs still need to be fumigated, but this should not be done until they are dry.

Figure 97: Range of egg temperatures in eggs collected at second egg collection – all the eggs had been laid within the previous 2 hours.

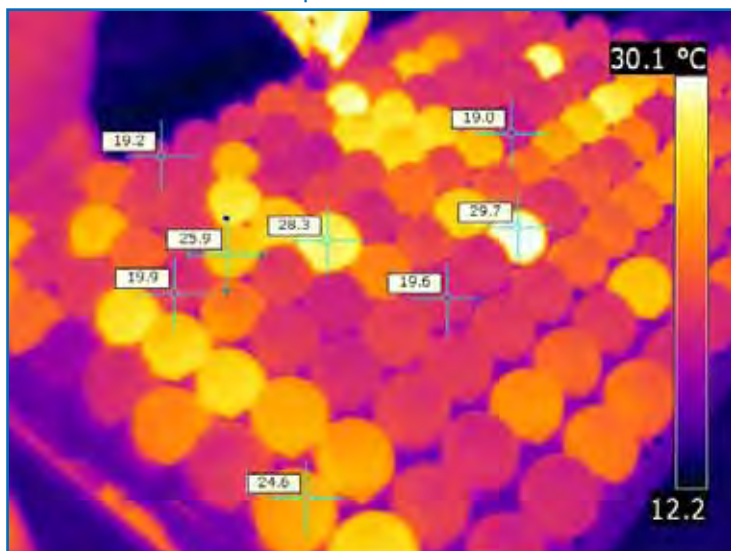

*The thermal image shows the range of temperatures of eggs collected from a colony-type auto nest. It is **not** safe to assume that eggs are uniformly cold when deciding a suitable wash temperature for cleaning soiled eggs.*

Egg storage conditions

After the egg is laid, it should be cooled so that cellular growth of the embryo is paused. Ideally, hatching eggs should all be set within 7 days of lay. Storage for longer than 7 days will result in a loss of hatch due to embryo cell death, and a decline in internal egg quality, especially albumen quality. When longer storage is unavoidable, a cooler storage temperature will help to keep the yolk and albumen in good condition.

Temperature

- Keep egg temperature constant once the eggs are cooled – watch for variable storage temperatures through the day and when doors are left open. It is important to coordinate temperatures with those used in transport to, and storage at, the hatchery. This will avoid fluctuating temperatures and condensation.
- Storage temperatures need to be set at a level that will maintain internal egg quality and keep the dormant embryos alive – long storage should be at lower temperatures than short-term storage (**Table 19**).
- On farm storage temperatures should be managed so that the temperatures are adjusted when the average storage duration changes.
- Keep the farm store 2°C (4°F) warmer than the hatchery store, with the truck temperature intermediate between the 2. This will help to avoid any condensation forming on the eggs.
- Do not blow cooler or heater fans towards eggs.

Table 19: Relationship between length of egg storage and temperature of egg store

Storage Period (days)	Temperature of Storage* °C (°F)
1-3	20-23 (68-73)
4-7	15-18 (59-64)
> 7	12-15 (54-59)
> 13	12 (54)

* Humidity between 75 and 80%

Humidity

- Egg store humidity should be held between 75 and 80% RH, to prevent the eggs losing too much moisture during storage.
- If cold eggs are moved into a warm humid atmosphere, condensation will form on the egg surface; as shown in **Figure 98**. For more information refer to the Dew Point or Condensation Table in the Appendices.
- Make sure that the water in the humidifier is clean (static reservoirs can encourage bacterial growth) and that spray nozzles are maintained properly so that they produce a fine mist of water and not large droplets.

Figure 98: Condensation on the surface of the egg.



KEY POINTS

- Nest cleanliness and regular/frequent egg collection are extremely important. Any egg laid onto dirt or droppings can easily become contaminated.
- There will be microbes even on the shells of clean hatching eggs. Unless there is effective disinfection of the egg shell surface before eggs arrive at the hatchery, they present a risk to hatchery hygiene and embryo survival and health.
- Formaldehyde fumigation is the best method for disinfecting egg shells. Ensure that temperature, humidity, and air circulation are appropriate for effective fumigation.
- Follow safety procedures.
- If an alternative to formaldehyde does need to be used, to be comparable to formaldehyde fumigation, the new method should kill 99% of shell surface bacteria, viruses and molds, give no increase in egg content bacterial counts, cause no or minimal cuticle damage, and give the same or better hatchability in both young and older flocks and after long egg storage.
- Monitor and record egg washing procedures. If the recommendations for washing eggs are not achieved, the level of rots and contamination in the washed eggs will be high, with poor hatch and chick quality.
- On farm storage temperatures should be adjusted for the oldest eggs – fresh eggs will hatch normally if kept at lower temperatures, whereas the hatch of longer-stored eggs will suffer if kept too warm.
- If there is condensation on the eggs, do not fumigate them and do not put them into the cooler until they have dried.

Problems resulting in rots and bangers

If the Hatchery is observing an excessive number of rots and bangers, check the following:

- The number and severity of dirty eggs being produced. Make sure nests and collection belts are checked regularly and cleaned immediately if a problem is spotted.
- Floor eggs are not washed and then mixed with nest eggs.
- The eggs are not collected or packed into dirty trays.
- The shell quality (increase in rejected or cracked eggs) is normal for the age of the flock. Shell quality can be damaged by inappropriate feed or respiratory diseases and will show up as a sudden increase in rejected and/or cracked eggs.
- Egg washing and disinfectant media are 41°C (106°F).
- Washed eggs are not mixed with clean eggs.
- Wet eggs are not being placed in the egg store.
- If the humidifier has a reservoir, replace it with one that operates off the main water supply. Flush the water pipes if the humidifier has not been used for a while.

KEY POINT

- If there is an excessive number of rots and bangers in the hatchery, investigate potential causes and take required action.

Section 7 - Environmental Requirements

Housing

Objective

To provide a protected environment in which temperature, humidity, ventilation, daylength, and light intensity can be controlled and optimized for the lifetime of the flock in order to achieve good reproductive performance without compromising health and welfare.

Principles

Farm location and house design must take into consideration climate and management systems.

Farm Location and Design

The location and design of a farm (**Figure 99**) will be affected by a number of factors, not least by local economics and regulations.

Figure 99: Examples of typical farm layouts & locations showing good biosecurity.



Climate

Temperature and humidity ranges experienced in the natural climate will influence which type of housing is most suitable (i.e. open or closed) and the degree of environmental control required.

Local planning regulations and laws

Local planning regulations and laws may stipulate important constraints in design (e.g. height, color, materials), and should be consulted at the earliest opportunity. Local law may also dictate a minimum distance from existing farms.

Biosecurity

The size, relative situation, and design of houses should minimize the transmission of pathogens between and within flocks. A policy of single (as opposed to multi-) aged sites is preferable. House design must facilitate effective cleaning-out procedures between flocks (see section on Health and Biosecurity).

Access

The farm location must allow for easy access to the site perimeter by heavy vehicles such as feed and egg trucks (i.e. road widths and turning circles must be appropriate for the vehicles servicing the farm).

Local topography and prevailing winds

These natural features have particular importance for open-sided housing. They can be exploited to minimize the entry of direct sunlight and for optimal ventilation or cooling. Open-sided houses should be positioned so that the length of the house is oriented in an east/west direction to minimize solar heat gain through the side wall. The existence of sites nearby, which present an airborne disease risk, must also be taken into account. It is best to build a farm in an isolated area at least 3.2 km (2 miles) from the nearest poultry or other livestock facility that may contaminate the farm.

Power availability and costs

Controlled environment housing requires a reliable source of power to operate electrical ventilation, heating, lighting, and feeding equipment. It is essential to have a back-up system/generator (**Figure 100**) and an appropriate alarm system installed in case of power failure.

Figure 100: Example of a back-up generator.



Water

A clean, fresh supply of water is required. (For more information on maximum acceptable concentrations of minerals and bacteria in the water supply see Health and Biosecurity section).

Drainage

Farm design features should allow for the separate disposals of rainwater and house cleanout water. This is a necessary part of biosecurity and environmental protection; being increasingly a regulatory requirement (refer to local legislation).

KEY POINTS

- Farm design will depend on location, climate, and local planning regulations.
- Farm location check list:
 - ✓Availability of power & water
 - ✓Local topography and prevailing winds
 - ✓Access
 - ✓Biosecurity

House Design

Controlled environment

Controlled environment (blackout) housing is preferred over open-sided housing. In particular during rear, since it limits variation due to environmental influences, permits greater control over daylength, facilitates control of maturity and body weight, and assists in the production of uniform flocks.

Size and number of houses

In determining the size and number of both rear and laying houses, the following should be considered:

- The number of eggs required per week.
- The number of birds required to achieve this level of production.
- The floor area required for this number of birds at the recommended stocking density.
- The pattern of egg production throughout lay.
- The time required for house cleaning and disinfection.
- The preferred/optimum individual house size (determined by the need to maintain the birds in an appropriate environment by managing the ventilation within the house effectively).
- The number of houses that the site can accommodate.

Stocking density

Stocking density will depend on local welfare legislation, climate, equipment, and local economics. Recommended stocking densities can be found in the sections on Rearing and Management into Lay.

House size

The house size selected must enable all of the daily feed allowance to be distributed evenly, and be accessible to all birds within a maximum of 3 minutes. This condition should be met for each pen/population within the house.

Lighting

Light should be uniformly distributed throughout the house. Light intensities and durations must achieve recommendations (see section on Lighting). Both should be controllable and adjustable. A light meter can be used to measure light intensity across the house at bird height.

Light proofing

Ventilation system design should include appropriate provisions for light proofing. Effective light traps should be fitted to all air inlets as well as fans. Light proofing is restrictive to airflow, and incorrectly designed/sized light proofing can be detrimental to the performance of the ventilation system, and hence to the well-being of the birds.

Light intensity should not exceed 0.4 lux (0.04 foot candles) during the dark period (see section on Lighting). This must be achievable at all stages of operation of the ventilation system.

Insulation

Insulation aids the effective operation of the ventilation system. The amount of insulation required will depend largely on the local ambient conditions in summer and winter, and is subject to local legislation.

Airtightness

Most modern housing utilizes negative pressure ventilation. In order for the ventilation system to work effectively, the house must be well sealed to prevent any uncontrolled air leaks into the house (i.e. the house must be airtight). This must be taken into account during the design and construction of the house. In particular, care should be given to the tunnel ventilation inlet as this is often the area of the house that has the most air leakage.

Ambient conditions

The local ambient climatic conditions will determine the type and size of the ventilation system required in order to maintain acceptable house conditions for the birds (see section on Ventilation for more details).

Heating

In most climates around the world, a heating system is required to keep the house at the desired set point temperature in the colder months, especially during the rearing stages. A partial list of available heating equipment includes spot brooders, whole-house space heaters, or a combination of both types (**Figure 101**). The actual heating equipment required will depend on local climate, house design, and local fuel availability.

Figure 101: Examples of different house heating systems (from left to right, canopy brooder, whole-house heating, and space heater).



The heating system should provide enough capacity to maintain the desired house temperature in the colder periods while allowing minimum ventilation requirements to be satisfied. Heat must be evenly distributed throughout the house and should be operated in combination with the main ventilation control system.

Biosecurity

In designing the structure of the house:

- Use materials that provide easily cleanable surfaces.
- Smooth concrete floors are easier to wash and disinfect.
- An area of concrete or gravel extending to a width of 1-3m (3-10 ft) free of vegetation around the house will discourage entry of rodents.
- Make sure the house is proofed against entry by wild birds.

In designing the layout of the farm:

- Provide shower facilities for staff entering and leaving the farm.
- If vehicles are to enter the farm (which is not desirable), then a spray booth or equivalent should be available to disinfect the vehicle.
- Locate feed bins along the fence line so that feed trucks do not need to enter the farm.

KEY POINTS

- House design check list:
 - ✓Environmental control type (controlled/natural)
 - ✓Egg requirements, bird numbers and stocking density
 - ✓Lighting and light proofing
 - ✓Insulation
 - ✓Heating
 - ✓Biosecurity
 - ✓Ventilation

Ventilation

Objective

To ensure that good welfare and reproductive performance are achieved by maintaining birds under appropriate, and where possible, optimal environmental conditions.

Principles

Ventilation is used to achieve an in-house environment which will optimize bird comfort, achieve the best biological performance, and maintain bird health and welfare. The ventilation system supplies adequate fresh air, and also removes excess moisture, gases, and airborne by-products. It also contributes to temperature and humidity control in all ambient conditions, and provides a uniform draft-free environment at bird level. Monitoring bird behavior is an essential part of ensuring that the correct ventilation is being achieved.

Open-sided/Natural Ventilation

Open-sided (or naturally ventilated) houses rely on the free-flow of air through the house for ventilation (**Figure 102**). Achieving adequate control of the in-house environment can be difficult in open-sided houses, and as a result, consistency and level of performance tends to be lower than in controlled environment houses.

Figure 102: Example of typical open-sided housing.



Airflow in open-sided houses is controlled by varying curtain height. Curtains should be fastened to the sidewall at the bottom, and be opened from the top down. This will minimize wind or drafts blowing directly on the birds.

Curtains should be opened on both sides of the building to provide cross ventilation. If there is light wind or the wind is changing directions, curtains on each side of the building should be opened the same amount. If winds are coming consistently from one side of the building, the curtain on the side of the prevailing wind should be opened less than the downwind side to minimize drafts on the birds. Recirculation fans can be used to supplement natural ventilation and enhance temperature control within the house.

Translucent curtain materials allow the use of natural light during daylight hours. Black curtains are used in situations where it is necessary to exclude daylight (e.g. to provide blackout during rearing).

Achieving adequate ventilation during hot weather can be difficult in open-sided houses. However, several steps can be taken to minimize the impact of hot weather. These include:

- Reducing flock stocking density.
- Insulating the roof to prevent radiant heat from the sun reaching the birds. In some instances water can be used to cool the roof. This strategy must be used with caution as runoff from the roof can lead to increases in relative humidity levels.
- Using circulation fans to create uniform air movement over the birds.
- Using tunnel ventilation system with evaporative cooling.

Naturally ventilated houses should be constructed to a specified width i.e. 9-12 m (30-40 ft) and a minimum height to the eaves of 2.5 m (8 ft), to ensure adequate airflow.

Negative Pressure Ventilation Systems (Controlled Environment Housing)

Most modern controlled environment housing uses negative pressure ventilation. This means that fans exhaust air out of the house and fresh air is drawn into the house through air inlets. This is called negative-pressure ventilation because it works by creating a partial vacuum inside the house.

When a negative pressure is created (as in-house air is drawn out of the house), fresh outside air enters evenly through all inlets in the house (**Figure 103**). As the negative pressure increases, so the speed of the air entering the house increases. In this way, pressure can be used to regulate the speed of the incoming air and how far the air will uniformly travel into the house before it turns and moves toward floor level.

Figure 103: Diagram illustrating airflow through air inlets in a negative pressure system

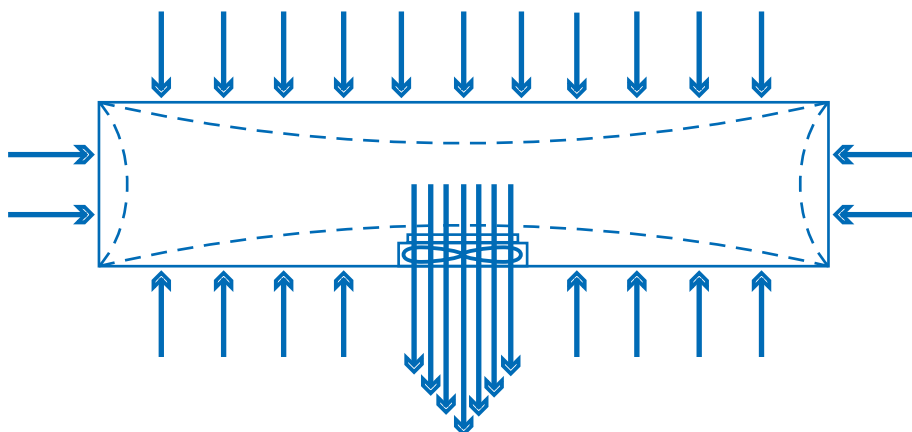

Negative pressure only works efficiently if the house is effectively sealed. In a house that is effectively sealed against air leaks all the air entering the house comes in through the desired air inlets and uncontrolled air leakage will be minimized.

To determine how well sealed (or airtight) a house is, close all doors and inlets in the house and switch on one 122 cm (48 in) / 127 cm (50 in) fan, or two 91 cm (36 in) fans. The pressure within the house should not measure less than 0.15 inches of water column (37.5 Pa). Pressure can be measured anywhere in the house and should be consistent throughout the house.

Air pressure within the house should be monitored regularly. Monitoring pressure over time is a useful means of identifying air leakage and easy-to-use pressure gauges (manometers) are available (**Figure 104**). If the air pressure falls below the suggested levels (0.15 inches of water column or 37.5 Pa) an investigation should be carried out, and appropriate action taken (e.g. repair broken inlets or ripped curtains).

Figure 104: A manometer used to monitor air pressure within the house (the reading given is equivalent to 0.15 inches of water column).



KEY POINTS

- For a negative pressure system to operate successfully the house must be airtight.
- Pressure should be monitored over time to identify the presence of any air leakage in to the house. If pressure drops below the desired levels corrective action should be taken immediately.

Minimum Ventilation

For as long as birds are present in the house, it is necessary to ventilate for some minimum amount of time – no matter what the outside weather is. During cool weather, or the brooding period, minimum ventilation is recommended. Minimum ventilation is regulated by a timer, not by a thermostat or temperature sensor. The purpose of minimum ventilation is to maintain good air quality and exhaust excess moisture. Extraction fans (usually 91 cm [36 in] in size) operating on a cycle timer (on/off) draw air into the house through sidewall or ceiling air inlets. It is recommended that a 5 minute cycle timer is used (**Figure 105**). This will help reduce wide environmental fluctuations in the house.

Figure 105: Example of a timer clock.



The air inlets operate on the basis of negative pressure, and direct the cold incoming air at high speed away from the birds up toward the apex of the ceiling where the warmer in-house air accumulates. This allows mixing of the cold air with warm air before it falls to the birds at floor level (**Figure 106**).

Figure 106: Correct airflow during minimum ventilation.

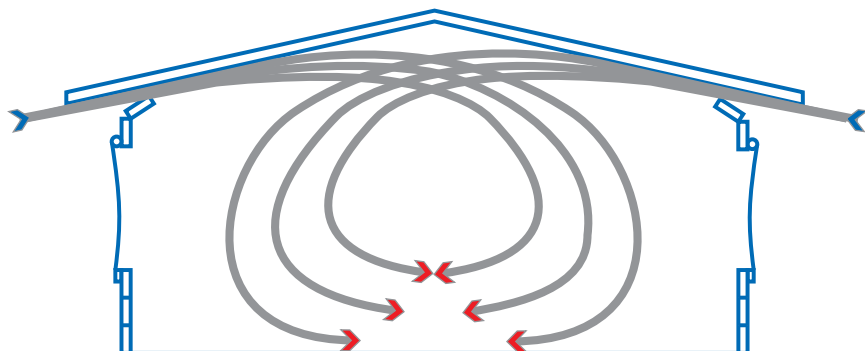

Where the ceiling has structural obstructions crossing the path of the airflow, it will be necessary to fit the air inlets with direction plates so that the incoming air can be directed below the obstruction, but still to the peak of the roof (**Figure 107**). Without direction plates, the incoming cold air will be deflected down onto the birds.

Figure 107: A direction plate fitted to an air inlet.



Air inlets should be opened at least 5 cm (2 in) for the airflow into the house to be effective. However, in most houses, if all the side wall inlets are allowed to open 5 cm (2 in) when the minimum ventilation fan is operating, the negative pressure within the house will be too low, and the speed at which the cold air enters the house will be reduced, thus increasing the risk of it falling directly onto the birds. Generally, for minimum ventilation, not all air inlets will need to be opened. Only some of the air inlets should be used, and the others should be prevented from opening. The inlets being used must be evenly distributed throughout the house, and all must be opened equally. Accurate settings for the house can be determined by carrying out smoke tests. Alternatively, strips of cassette tape can be hung from the ceiling every 1-1.5 m (3-5 ft) in front of an air inlet up to the apex of the house. Both methods will help to show the movement of the air as it enters the house indicating if the operating pressure is suitable. If the operating pressure is too low, cold incoming air will fall directly onto the birds (**Figure 108**), and the number of air inlets open should be reduced.

Figure 108: Illustration of airflow into the house. The picture on left shows a correct fast airflow during minimum ventilation, the picture on right shows an incorrect slow airflow during minimum ventilation.



The only way to properly evaluate the actual minimum ventilation rate being used is by frequently visiting the house. Environment evaluation should be done each time the manager visits the house. During the visit, the manager should observe and take note of things such as bird behavior, air quality, air pressure, relative humidity, signs of condensation, and dust levels. Based on these observations, a decision can then be made about whether the minimum ventilation is adequate or should be increased or decreased.

KEY POINTS

- It is essential to provide some ventilation to the house regardless of the outside conditions.
- Minimum ventilation is used for young chicks, nighttime, or winter ventilation.
- Minimum ventilation should be timer driven.
- Air inlet number and size of opening should achieve high air velocity to prevent cold air dropping to the floor.
- When setting up the minimum ventilation inlets, the minimum opening size should be around 5 cm (2 in).
- Monitor airflow and bird behavior to determine if settings are correct.

Minimum ventilation fan timer setting calculation

The steps for determining the fan timer settings for achieving minimum ventilation are given below. A full worked example calculation can be found in the Appendices. Recommended minimum ventilation rates per bird are given in **Table 20**.

Prior to 1 week (7 days), the actual speed at floor level should not be more than 0.15 m/sec (30 ft/min).

Table 20: Approximate minimum ventilation rates per bird.

Age	Cubic Meter per Hour (CMH/bird)	Cubic Feet per Minute (CFM/bird)
1-8 weeks	0.16	0.10
9-15 weeks	0.42	0.25
16 – 35 weeks	0.59	0.35
36 weeks - depletion	0.76	0.45

Step 1: Determine the appropriate minimum recommended ventilation rate (**Table 20** can be used as a guide). The exact rates will vary with temperature and for each individual poultry house, and with company of fan manufacture (fan type).

Step 2: Calculate the total ventilation rate required for the house:

$$\text{Total minimum ventilation} = (\text{minimum ventilation rate per bird}) \times (\text{number of birds in the house})$$

Step 3: Calculate the percentage time the fans are required to run:

$$\text{Percentage of time} = \frac{(\text{total ventilation needed})}{(\text{total capacity of fans used})}$$

Step 4: Multiply the percentage time the fans are required to run by the total fan timer cycle to give the amount of time that the fans are required to be on in each cycle.

Transitional Ventilation

Transitional ventilation is used when the house temperature is above the desired (or set point) temperature, but it is not yet warm enough, or the birds are still not old enough, to use tunnel ventilation. Transitional ventilation is a temperature driven process. As the house temperature increases above the required set point, the ventilation system should be set to stop operating minimum ventilation (cycle timer), and start to ventilate continuously for temperature control (transitional ventilation).

Transitional ventilation works in a similar way to minimum ventilation; air inlets operating on the basis of negative pressure direct the incoming air, at speed, away from the birds up to the apex of the house where it mixes with warm in-house air before falling back to floor level. With transitional ventilation a larger fan capacity gives a larger volume of air exchange and transitional ventilation requires more inlet area compared to minimum ventilation (**Figure 109**). A general guideline for transitional ventilation is to open enough air inlets so that approximately 40-50% of the tunnel fan capacity is being used.

Figure 109: Typical air movement during transitional ventilation.

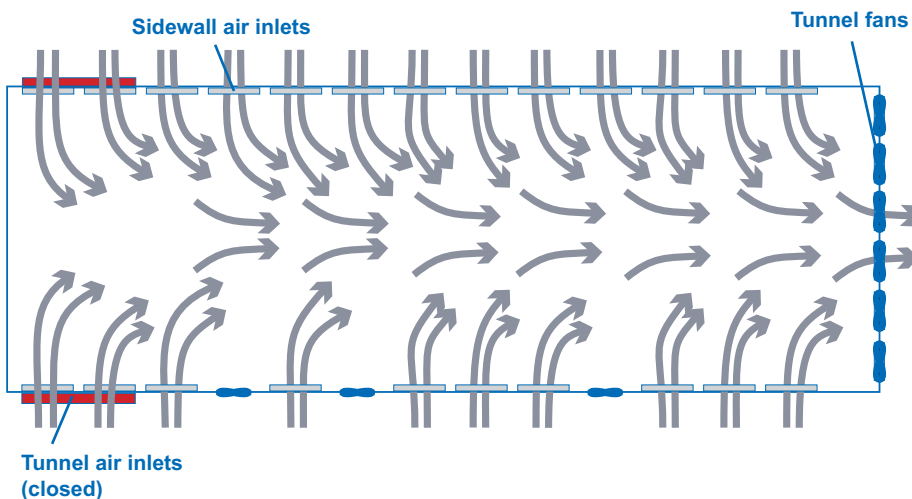

KEY POINT

- Transitional ventilation is used when a higher than minimum air exchange is required.

Tunnel Ventilation

Tunnel ventilation is used to keep the birds feeling cool. **Figure 110** shows a typical tunnel ventilated house.

Figure 110: Example of a typical tunnel ventilated house.



The system uses fans (usually 122 cm [48 in] or 127 cm [50 in]) at one end of the house, and air inlets at the other end. High volumes of air are drawn down the length of the house, exchanging the air in the house in a short time (**Figure 111**).

Figure 111: Airflow in a tunnel ventilated house.

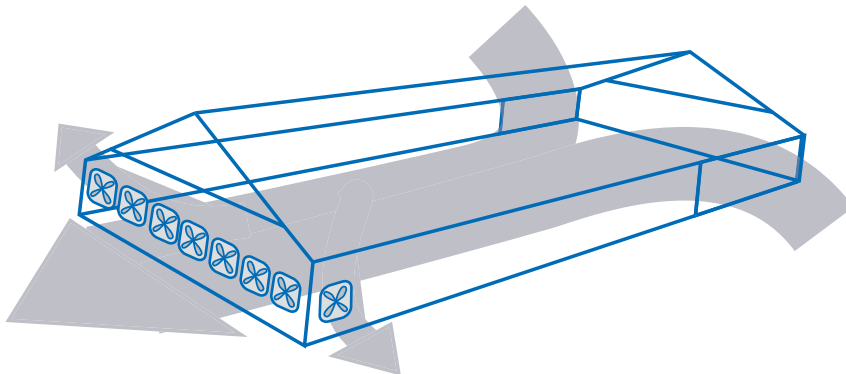

The switch from transitional ventilation to tunnel ventilation should occur when the birds need the cooling effect of wind chill. The heat generated by the birds is removed and a wind chill effect is created which allows the birds to feel a temperature that is lower than that shown on the thermometer or temperature probe/sensor. For any given wind speed, younger birds which are not fully feathered will feel a greater wind chill than older birds and so are more prone to wind chill effects. After 7 weeks of age birds are expected to be fully feathered and the effects of wind chill are less.

The actual temperature felt by the birds during tunnel ventilation is known as the effective temperature. The effective temperature is a result of a combination of various factors including bird age, air speed, dry bulb temperature of the air, and relative humidity. Effective temperature cannot be measured so observations of bird behavior are critical to determine if birds are too hot or too cold when tunnel ventilation is operating.

When using tunnel ventilation for cooling, birds will tend to move (migrate) towards the cooler, inlet end of the house, resulting in crowding. If the breeder house is not routinely divided into pens (which will prevent migration) the addition of migration partitions should be considered.

KEY POINTS

- Tunnel ventilation cools birds through high-velocity airflow.
- Tunnel ventilation controls the effective temperature felt by the bird which can only be estimated by bird behavior.
- If the house design permits tunnel ventilation only, then considerable caution should be practiced with young birds which are not fully feathered. Younger birds feel a greater wind chill than older birds for a given air speed, and thus are prone to wind chill effects.
- Observations of bird behavior are critical.

Tunnel ventilation calculations

The steps to determine the number of fans required for tunnel ventilation are given below. A full worked example calculation can be found in the Appendices.

Step 1: Determine the fan capacity required for a given air speed.

Required fan capacity = (design air speed) x (cross section area)

Where:

- Design air speed (minimum):
 - » 2.03 meters per second (m/s) or 400 feet per minute (fpm) for rearing.
 - » 2.54 meters per second (m/s) or 500 feet per minute (fpm) for production.
- Cross section area = $(0.5 \times W \times R) + (W \times H)$ (see **Figure 112**).
- Cross section area is the effective area through which the air flows down the length of the house. If there are other major obstructions such as nests in the house, then the area of these obstructions can be subtracted from the total cross section area.

Figure 112: Elevation of house showing height (H), width (W), roof (R) for calculating cross section area for tunnel ventilation calculations.

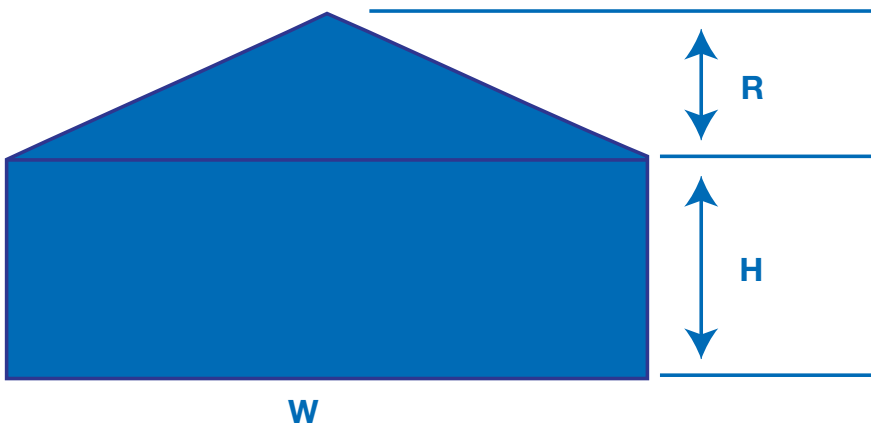

Step 2: Determine the number of fans required.

Number of fans = $\frac{\text{(required fan capacity)}}{\text{(fan operating capacity)}}$

Where:

- Fan operating capacity is the capacity at the assumed operating pressure.
- As a guideline for tunnel ventilation with cooling pads, use the fan capacity at an operating pressure of 37.5 Pa (0.15 inches water column).

Evaporative cooling systems

Evaporative cooling improves environmental conditions in hot weather and enhances tunnel ventilation. The air is cooled either as it enters the house or as it travels through the house. Evaporative cooling systems are commonly used when temperatures exceed 27°C (81°F). Effectiveness of evaporative cooling systems depends on the relative humidity levels.

There are 2 main types of evaporative cooling - spray cooling and pad cooling.

Spray cooling (fogger)

Spray cooling or fogger systems consist of spray nozzles distributed inside the house (**Figure 113**), and are often categorized as either high or low pressure. Fogging lines must be placed near air inlets in order to maximize the speed of evaporation, and additional lines should be placed throughout the house.

High pressure (water) spray systems operate at 400-600 psi (28-41 bar), and produce a very fine mist with a droplet size of 10-15 microns. Better cooling can be achieved from a high pressure system than from a low pressure system.

Low pressure fogging systems operate at 100-200 psi (7-14 bar), and produce a droplet size greater than 30 microns. Because of the low operating pressure, the droplet size produced by this system is larger than that of the high pressure system, and as a result it can cause wet litter.

Figure 113: Example of spray cooling system.



Pad cooling

In pad cooling systems, cool air is drawn through a water soaked filter (cooling pad) by the tunnel ventilation fans (**Figure 114**).

Figure 114: Example of a cooling pad.



Calculation of cooling pad area (a full worked example calculation is given in the Appendices):

$$\text{Cooling pad area} = \frac{\text{(tunnel fan capacity)}}{\text{(pad air speed)}}$$

Where:

- Cooling pad area is the total area required. Half of this area is usually installed on each outside wall at the inlet end of the house.
- Tunnel fan capacity is the actual total operating capacity.
- Pad air speed refers to the speed of the air traveling through the pad. As a guideline:
 - For 100 mm (4-in) thick pad, use 1.27 m/s (250 fpm)
 - For 150 mm (6-in) thick pad, use 1.91 m/s (375 fpm)

Because evaporative cooling adds moisture to the air and increases relative humidity, it is recommended that evaporative cooling be switched off when the relative humidity in the house exceeds 70-80%.

KEY POINTS

- Evaporative cooling enhances tunnel ventilation in hot weather.
- Evaporative cooling adds moisture to the air and increases relative humidity. It is important to operate the system based on relative humidity, as well as dry bulb temperature, to ensure bird welfare.
- It is not recommended to use evaporative cooling if the RH in the house exceeds 70-80%.

Lighting

Objective

To achieve optimal reproductive performance through appropriate illumination (daylength and light intensity) and photostimulation (increase in daylength) at the correct age and body weight.

Principles

All broiler breeders are hatched photorefractory. This means that they are unable to respond positively to a stimulatory (long or ≥ 11 hours) daylength. The ability to respond to a stimulatory daylength depends upon birds being exposed first to a period of neutral or short days (8 hours); at least 18 weeks for typically grown broiler breeders. Long daylengths (≥ 11 hours) during the rearing period should be avoided as they will delay sexual development, reduce egg numbers, and increase egg weight.

After prolonged exposure to long daylengths, birds become adult photorefractory. This means they are no longer responsive to a long stimulatory daylength, and production begins to decline.

Lighting for broiler breeders aims to dissipate juvenile photorefractoriness, and ensure that all birds are photosensitive and can positively respond to stimulatory daylengths in ways that optimize lay.

Lighting During Brooding

Regardless of housing type, for the first 2 days after placement birds should be given 23 hours of light and 1 hour of dark a day. This will help appetite development and promote feeding activity. Where closed (controlled environment) housing is used during rear, daylength should be gradually reduced to 8 hours by 10 days of age.

Light intensity in the brooding area during the first few days should be bright (80-100 lux [8-10 foot candles]) to ensure that the birds find feed and water, but from 6 days of age this should be reduced to between 30 and 60 lux (3-6 foot candles) in controlled environment housing, and 60-80 lux (6-8 foot candles) in open-sided housing.

Lighting Programs and Housing Type

Different types of housing in the rearing and/or laying periods mean that there are 3 common combinations of lighting environment:

1. Closed rearing house (controlled environment), and closed laying house (controlled environment).
2. Closed (controlled environment) or blackout rearing house, and open-sided (natural environment) laying house.
3. Open-sided rearing house (natural environment), and open-sided laying house (natural environment).

The recommended lighting programs for each of these 3 environments are given on the next page. All lighting programs will achieve 5% production at 25 weeks of age. If the target for production is different to 5% at 25 weeks, then the age at which first light increase is given should be altered accordingly. Typically, it will take between 14 and 21 days from photostimulation to 5% egg production, with lighter birds taking longer to start laying eggs than heavier ones.

Lighting programs for controlled environment rearing and controlled environment laying

Controlled environment housing during rear permits greater control over daylength. The ability to control daylength so that birds receive a constant short daylength from 10 days of age resolves many production problems (for example, delayed sexual maturity, high female body weight, poor flock uniformity, and high feed consumption), and gives better control of undesirable behaviors. The proportion of abnormal eggs and the risks of prolapse, broodiness and egg peritonitis, and other conditions reducing welfare and performance can be minimized by ensuring that:

- Birds are at target body weight for their age.
- Have good body-weight uniformity.
- The lighting programs shown in **Table 21** are followed.

Achieving satisfactory production from birds kept in controlled environment housing (**Figure 115**) depends on the adequacy of the light proofing. In dark periods, light intensity should not exceed 0.4 lux (0.04 foot candles). Measures should be taken to avoid light leakage through air inlets, fan housings, door frames, etc., and regular checks should be made to verify the effectiveness of the light proofing.

Figure 115: A typical controlled environment house with full lighting control which can control the light intensity to a maximum 0.4 lux (0.04 foot candles) in the dark period.



Light proofing is especially important during rear, when the birds need to experience a period of short days (8 hours) before they can become responsive to the pre-lay increase in daylength.

Table 21 details the recommended lighting program for birds kept in controlled environment housing. In rear, a constant daylength of 8 hours is achieved by 10 days of age and maintained until photostimulation (transfer to a stimulatory daylength).

To achieve the recommended 5% production at 25 weeks of age, photostimulation should not occur before 147 days (21 weeks). The actual age at which daylength is increased from short (8 hours) to long (≥ 11 hours) days depends on the average flock body weight and flock uniformity. An assessment of flock uniformity should be made at 140 days (20 weeks) of age or approximately 1 week before the first light increase is planned.

Flocks that are underweight (100 g [0.22 lbs] or more below recommended target weight for age) or uneven (CV greater than 10%) should have photostimulation delayed (by at least 1 week). Transferring to long days before all birds have dissipated photorefractoriness will delay sexual development in those birds that are still photorefractory. This will result in a sexually uneven flock with poor peak rates of lay, widely ranging egg weights, and a flock for which nutrition is difficult to manage.

Table 21: Lighting programs for controlled environment rearing and controlled environment laying.

AGE		DAYLENGTH For Flocks with Different CV% at 140 Days (20 Weeks)		LIGHT INTENSITY†
		BROODING DAYLENGTHS* (Hours)		
Days	Weeks	CV 10% or Less	CV >10%	
1		23	23	80-100 lux (8-10 foot candles) in brooding area. 10-20 lux (1-2 foot candles) in the house.
2		23	23	
3		19	19	
4		16	16	
5		14	14	
6		12	12	30-60 lux (3-6 foot candles) in the brooding area. 10-20 lux (1-2 foot candles) in the house.
7		11	11	
8		10	10	
9		9	9	
		REARING DAYLENGTHS (Hours)		
10-147		8	8	10-20 lux (1-2 foot candles).
Days	Weeks	LAYING DAYLENGTHS (Hours)		
147	21	11‡	8	30-60 lux (3-6 foot candles).
154	22	12‡	12‡	
161	23	13‡	13‡	
168	24	13‡	13‡	
175	25	13	13	

* Constant 8-hour daylengths should be reached by 10 days of age. However, if problems have regularly occurred with early body-weight gain, the reduction to a constant daylength may be more gradual so that 8 hours is not reached until 21 days.

† Average intensity within a house or pen measured at bird-head height. Light intensity should be measured in at least 9 or 10 places and include the corners, under lamps and between lamps. During the dark period (interpreted as night) a light intensity of ≤ 0.4 lux (0.04 foot candles) should be achieved. Ideally, variation in light intensity within the house should not exceed 10% of the mean.

‡ Daylength may be increased abruptly in a single increment without adversely affecting total egg production (although peak may be higher and persistency slightly poorer) provided the body weights are on target and the flock is uniform (CV ≤ 10%).

During lay, there is no advantage in exceeding 13 to 14 hours of light per day at any stage (where light proofing is good, there is no need to go beyond 13 hours). Giving more than 14 hours of light will advance the onset of adult photorefractoriness and result in inferior rates of lay at the end of the laying cycle. Providing less than 13 hours of light during lay will increase the number of floor eggs as birds will lay eggs before lights-on.

Males reared to the recommended body-weight profile and lighting program will not require increases in daylength ahead of females. Achieving target body-weight profiles with good uniformity will ensure synchronization of sexual maturity between the 2 sexes (see section on Management into Lay).

Light intensity (luminance) in lay

It is recommended that increases in light intensity are made at the same time as the increase in daylength. However, provided birds have achieved the target body weights and have good uniformity ($CV \leq 10\%$), it is the increase in daylength that stimulates sexual maturity and optimizes subsequent laying performance, not changes in light intensity. As long as the minimum intensity at bird-head height in the laying house is greater than 7 lux (0.7 foot candles), changes in light intensity when the birds are transferred from the rearing to the laying facilities have minimal effect on sexual development and subsequent egg production. The recommended average light intensity at bird-head height in the laying house is between 30 and 60 lux (3 and 6 foot candles). This brighter intensity is recommended to encourage the use of nest boxes and maximize hatching egg production by minimizing the number of eggs laid outside the nest boxes.

KEY POINTS

- The maximum response to pre-lay increases in daylength is only obtained by achieving the correct body-weight profile during the rearing period, good flock uniformity, and the appropriate nutritional input.
- Birds should be provided with a constant short daylength (8 hours) by 10 days of age.
- At least 18 weeks of short daylengths (8-10 hours) are needed during rear to dissipate juvenile photorefractoriness and ensure that all birds are photosensitive when they are transferred to stimulatory daylengths (≥ 11 hours).
- An average intensity of 10-20 lux (1-2 foot candles) at bird-head height should be provided in the rearing period from 10 days of age.
- Houses must be light proofed to an intensity of no more than 0.4 lux (0.04 foot candles) during the dark periods. Any light leakage should be rectified immediately to ensure that the birds do not experience long days in rear.
- The birds' reproductive response is maximized by a 13 or 14-hour daylength in the laying period. This will delay the onset of adult photorefractoriness and will minimize the incidence of 'floor-eggs' by ensuring that most eggs are laid after the lights come on.
- An average intensity of 30-60 lux (3-6 foot candles) at bird-head height should be provided in the laying period.
- Ensure males and females are synchronized in terms of sexual maturity by rearing them on the same lighting program and to the respective target body weights for age.

Lighting programs for controlled environment/blackout rearing and open-sided laying house

Where controlled environment rearing to natural environment laying (**Figure 116**) is practiced, daylength should be maintained at 8 or 9 hours (see **Table 22**) from 10 days of age until the flock is photostimulated. In latitudes where problems such as prolapse, broodiness, or high pre-peak mortality frequently occur, it may be advantageous to rear birds on a 10-hour daylength.

Figure 116: Example of an open-sided (natural environment) laying house.



The flock should be transferred to open-sided laying houses (i.e. rear and move) or the blackout curtains should be opened (i.e. day-old to depletion) at the same time as the first pre-lay light increase is given (147 days [21 weeks] if the desired age at 5% production is 25 weeks).

There is no benefit to reproductive performance of providing birds with more than 14 hours light during the laying period. However, where birds are kept in open-sided houses and the longest natural daylength exceeds 14 hours, the combined natural and artificial lighting during the laying period may be increased, beyond 14 hours, to equal the longest natural daylength. This will prevent the birds experiencing a decrease in daylength after the longest natural daylength has occurred in mid-summer.

To ensure the synchronization of sexual development, rear males and females on the same lighting program.

Table 22: Lighting programs for controlled environment/blackout rearing and open-sided house laying.

	NATURAL DAYLENGTH (Hours) at 147 Days (21 Weeks)							LIGHT INTENSITY†	
	9	10	11	12	13	14	15		
Age (Days)	BROODING DAYLENGTH (Hours) ‡								
1	23	23	23	23	23	23	23	80-100 lux (8-10 foot candles) in brooding area. 10-20 lux (1-2 foot candles) in house.	
2	23	23	23	23	23	23	23		
3	19	19	19	19	19	19	19		
4	16	16	16	16	16	16	16		
5	14	14	14	14	14	14	14		
6	12	12	12	12	12	12	12	60-80 lux (6-8 foot candles) in brooding area. 10-20 lux (1-2 foot candles) in house.	
7	11	11	11	11	11	11	11		
8	10	10	10	10	10	10	11		
9	9	9	9	9	10	10	10		
Age (Days)	REARING DAYLENGTH (Hours)								
10-146	8	8	8	8	9	9	9	10-20 lux (1-2 foot candles).	
Age (Days)	Age (Weeks)	LAYING DAYLENGTH (Hours) ¶							
147	21	12#	12#	12#	13#	14	14	15§	Artificial lighting 30-60 lux (3-6 foot candles).
154	22	13#	13 #	13#	13#	14	14	15§	
161	23	14	14	14	14	14	14	15§	

‡ Constant 8-hour daylengths should be achieved by 10 days. However, if problems have regularly occurred with early body-weight gain, reaching the constant daylength may be delayed until 21 days.

† Average intensity within a house or pen measured at bird-head height. Light intensity should be measured in at least 9 or 10 places and include corners, under lamps and between lamps.

#The daylength may be increased abruptly in a single increment without adversely affecting total egg production (although peak may be higher and persistency slightly poorer) provided the body weights are on target and the flock is uniform (CV ≤ 10%).

§ There is no benefit to be gained from exceeding a daylength of 14 hours. If the longest natural daylength exceeds 14 hours, the combination of natural and artificial light should be increased to equal the expected longest natural daylength.

¶ If problems occur in out-of-season flocks (i.e. delayed sexual maturity), the flock may be photostimulated at 140 days (20 weeks) provided the body weights are on target and their CV is no more than 10%.

KEY POINTS

- The maximum response to the pre-lay increase in daylength is only obtained by achieving the correct body-weight profile during rear, good flock uniformity, and the appropriate nutritional input.
- Provide birds with a constant short daylength (8 or 9 hours) by 10 days of age.
- During rear, ensure that houses are light proofed to an intensity of no more than 0.4 lux (0.04 foot candles) during the dark period.
- Where birds are kept in open-sided housing during lay, and the longest natural daylength exceeds 14 hours, the combined artificial and natural lighting may be extended beyond 14 hours to equal the longest natural daylength.
- Ensure males and females are synchronized in terms of sexual maturity by rearing them on the same lighting program and to the respective target body weights for age.

Lighting programs for open-sided house rearing – open-sided house laying

There are 4 lighting situations in open-sided house rearing (**Figure 117**):

1. Natural daylength increasing throughout the rearing period.
2. Natural daylength increasing at the beginning, but decreasing towards the end of the rearing period.
3. Natural daylength decreasing throughout the rearing period.
4. Natural daylength decreasing at the beginning, but increasing towards the end of the rearing period.

Figure 117: Example of an open-sided rearing house where there is no control over the ambient lighting conditions.



These changes in natural daylength patterns are illustrated in **Figure 118**. For each month of placement, different shading/colors indicate the pattern of increasing or decreasing hours of daylight during rear. For example, a flock placed at the start of October in the Northern Hemisphere, or April in the Southern Hemisphere will have decreasing natural daylight up to 10-12 weeks, and then increasing natural daylight.

Figure 118: Patterns of natural daylength in the rearing period – Northern and Southern Hemisphere.

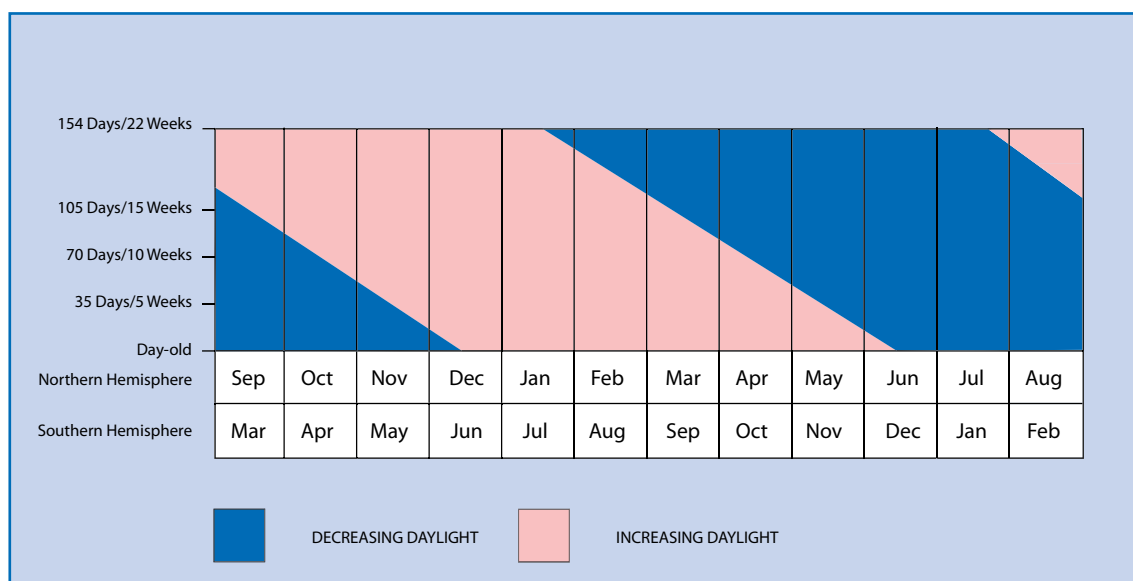

Note: The actual hours of daylength experienced will vary according to latitude.

In the past there has been concern that rearing birds on an increasing daylength pattern will result in an undesirably early sexual maturity, an increased incidence of prolapse, higher mortality, and smaller eggs. However, it is now known that this does not happen. Broiler breeders are photorefractory and require a period of short days to dissipate juvenile photorefractoriness and become photosensitive. Long daylengths during the rearing period will therefore delay, and not advance, sexual development. Furthermore, the influence of lighting on sexual maturation in broiler breeders is dependant upon achieving the correct feeding regimen and body weight for age. It is therefore recommended that birds reared in open-sided houses are allowed to experience whatever changes occur in the natural daylength during the rearing period.

It is important that broiler breeders are not given artificially long daylengths during the rearing period, as has previously been recommended, because this will delay sexual maturity and lead to poor rates of lay at the end of the laying cycle due to an advance in the onset of adult photorefractoriness.

The age at which a flock reaches sexual maturity will depend on the changing patterns of daylength during the rearing period, and the size of the increase in daylength given at photostimulation.

The lighting programs given in **Table 23** have been designed to minimize the adverse effects of keeping birds in open-sided housing. However, the performance of flocks reared in open-sided houses will always be poorer than that of flocks kept in controlled environment or light proofed houses.

Table 23: Lighting programs for open rearing and open house laying.

		NATURAL DAYLENGTH At 10 Days (Hours)						LIGHT INTENSITY†	
		9	10	11	12	13	14		15
Age (Days)		BROODING DAYLENGTH (Hours)							
1		23	23	23	23	23	23	80-100 lux (8-10 foot candles) in brooding area.	
2		23	23	23	23	23	23		
3		19	19	19	19	19	19		
4		16	16	16	16	16	16		
5		14	14	14	14	14	15		
6		12	12	12	12	13	14	> 60-80 lux (6-8 foot candles) in brooding area.	
7		11	11	11	12	13	14		
8		10	10	11	12	13	14		
9		9	10	11	12	13	14		
		REARING DAYLENGTH							
10-146 days		Natural lighting						Natural light intensity.	
		NATURAL DAYLENGTH (Hours) at 147 Days (21 Weeks)							
		9	10	11	12	13	14	15	
Age (Days) (Weeks)		LAYING DAYLENGTH (Hours)							
147	21	12#	13#	14	14	14	14	15§	Supplementary artificial lighting 30-60 lux (3-6 foot candles), but 60 lux (6 foot candles) for spring- hatched flocks.
154	22	13#	14	14	14	14	14	15§	
161	23	14	14	14	14	14	14	15§	

† Average intensity within a house or pen measured at bird-eye height.

The daylength may be increased abruptly in a single increment without adversely affecting total egg production (although peak may be higher and persistency slightly poorer) provided the body weights are on target and the flock is uniform (CV ≤ 10%).

§ There is no benefit to be gained from exceeding a daylength of 14 hours, if the longest natural daylength exceeds 14 hours the combination of natural and artificial light should be increased to equal the expected longest natural daylength.

KEY POINTS

- The maximum response to pre-lay increases in daylength is only obtained by achieving the correct body-weight profile during the rearing period, good flock uniformity and the appropriate nutritional input.
- If reared in open-sided housing, broiler breeders should be allowed to experience whatever changes occur in the natural daylength. Never rear birds on artificially long days (≥ 11 hours), even for spring-hatched or out-of-season birds, as this will delay sexual maturity, and egg numbers will be reduced.
- Where birds are kept in open-sided housing during lay and the longest natural daylength exceeds 14 hours, the combined artificial and natural lighting may be extended beyond 14 hours to equal the longest natural daylength.
- Ensure males and females are synchronized in terms of sexual maturity by rearing them on the same lighting program and to the respective target body weights for age.

Artificial lights and light intensity

In open-sided housing, it is important that the light intensity provided during the period of artificial lighting is bright enough to ensure photostimulation. The target light intensity in the house is 30-60 lux (3-6 foot candles). During times of the year when flocks have been reared in high intensity natural light (i.e. spring-hatched birds), higher intensities of artificial light will need to be provided in the laying house. This is essential to ensure satisfactory reproductive performance.

Supplementary artificial lighting should be given at both ends of the 'natural' day. This will clearly define the birds' 'day' and ensure that the daylength does not vary from that desired due to changes in sunrise and sunset. The transition from natural darkness to artificial lighting in the morning will give a definite 'dawn' signal to the birds, and the transfer from artificial lighting to natural darkness will give a definite 'dusk' signal. The latter is important because it is dusk that controls the timing of ovulation and, as a consequence, the time of egg laying. The proportion of artificial lighting given at each end of the birds' day will depend upon management factors such as what time the farm staff start work, and when eggs are required for collection.

In open-sided houses, seasonal effects can be significantly reduced if the intensity of the natural light entering the house is reduced. The use of black-plastic horticultural netting for example will reduce the intensity of the light entering the house while still allowing adequate ventilation. The netting should be removed at the first pre-lay light increase.

KEY POINTS

- Birds may be slower to come into lay if the artificial light intensity at the first pre-lay light increase is less than 60 lux (6 foot candles) when they have been reared on high intensity natural daylight.
- Artificial light should be given at both ends of the day to maintain a fixed daylength.

Seasonal variations in natural daylength

When rearing and/or laying houses are open-sided, seasonal variations will affect performance. Seasonal changes are gradual and so a precise definition of whether certain months of the year are classified as in- or out-of-season is difficult to establish. Some months are neither one nor the other. Latitude will influence seasonal effect (see **Figure 119**).

Figure 119: Natural day lengths at latitude 10° or 30° north or south .

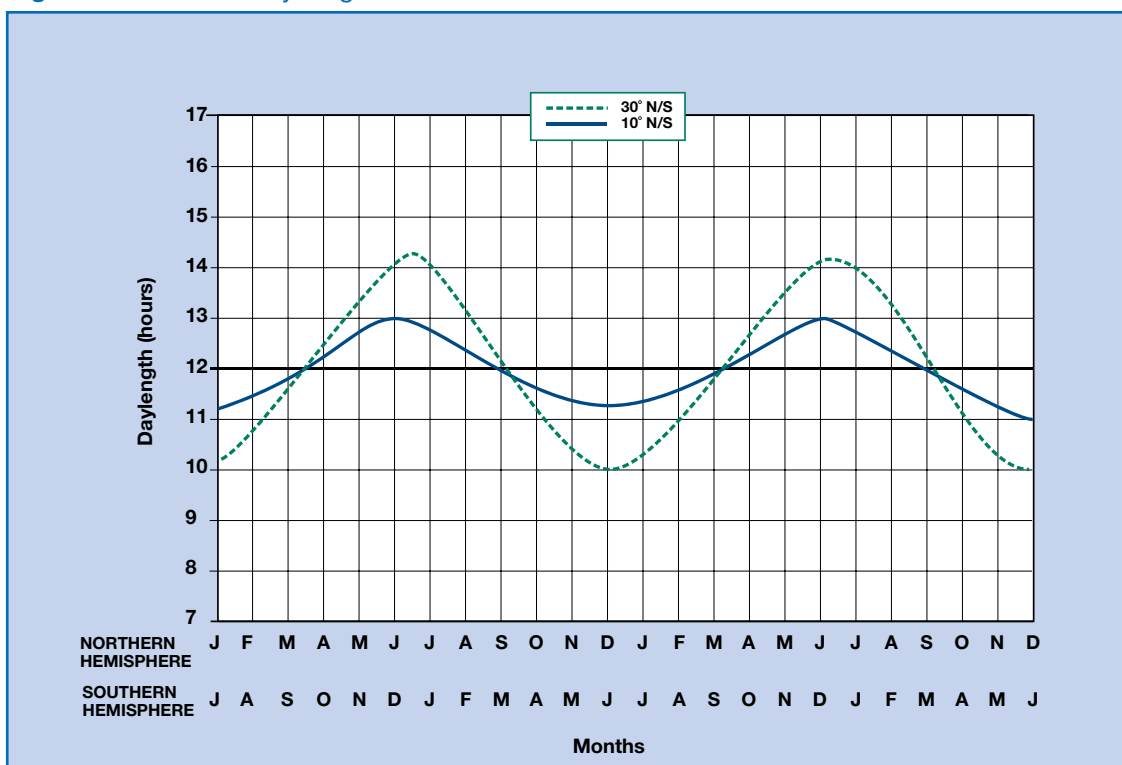

The months in which the birds are placed are classified as in-season, or out-of-season in **Table 24**.

Table 24: Classification of months of placement as in-season or out-of-season.

IN-SEASON		OUT-OF-SEASON	
Northern Hemisphere	Southern Hemisphere	Northern Hemisphere	Southern Hemisphere
September	March	March	September
October	April	April	October
November	May	May	November
December	June	June	December
January *	July *	July *	January *
February *	August *	August *	February*

* These 4 months are difficult to define. The degree of seasonal effect in these months will depend on latitude. Slight modifications of the lighting programs and body-weight profiles may be necessary.

Out-of-season flocks

The age at onset of lay for flocks hatched between March and August in the Northern Hemisphere, and between September and February in the Southern Hemisphere, will be delayed due to the birds having no or insufficient short days (8-10 hours) to satisfactorily dissipate photorefractoriness, and make the birds photosensitive. Compared to in-season flocks, out-of-season flocks will come into production later and have lower peaks, larger eggs, and less predictable reproductive performance throughout lay. Sexual maturity for out-of-season flocks can be advanced by easing the degree of body-weight control (see the Ross Parent Stock Performance Objectives for more information). Growing out-of-season females to a heavier out-of-season body-weight target will allow photorefractoriness to be dissipated more rapidly, helping to reduce issues of egg production and egg size.

The performance of spring-hatched (out-of-season) birds can be improved by rearing them in brown-out housing (use of netting to reduce light penetration into the house) on short (8-10 hours), artificial day lengths. However, it is unlikely that production from out-of-season flocks will ever be as good as that from in-season (autumn-hatched) flocks. The pre-lay light increase should be given at 147 days (21 weeks) - if desired age at 5% production is 25 weeks - and given as a single increment to 14 hours or 15 hours where the longest anticipated natural daylength is longer than 14 hours.

In-season flocks

In-season flocks should be grown to the target body-weight profile and the first pre-lay light increase given at 21 weeks (147 days) to achieve 5% at 25 weeks of age.

KEY POINTS

- The lighting program for both in-season and out-of-season flocks is the same (see **Table 23**).
- Out-of-season birds should be grown to a heavier out-of-season body-weight profile.
- In-season birds should follow the standard target weights.

Wavelength (Light Color) and Lamp Type

There is no strong scientific evidence to show that one particular color of light gives better performance than white light, which contains all colors of the light spectrum.

There may be some beneficial effects on fertility from providing UV-A in addition to white light (natural light has about 7% UV-A). Broiler breeders have UV-A reflective markings on their plumage, and the provision of UV-A light may aid bird recognition. There is some evidence that females use this factor to choose individual males, while males are more active and perform a greater number of attempted matings when UV-A light is provided.

There are no data to show that one type of lamp induces better performance than any other, and so lamp choice will depend on availability, capital outlay, running costs, and the ability to dim using conventional voltage-reduction equipment.

KEY POINTS

- There is no need to provide broiler breeders with anything other than white light.
- Lamp type does not have an effect on reproductive performance.

Section 8 - Nutrition

Nutrition

Note: This section should be used in conjunction with the separate supplements for this Handbook, namely the Ross Parent Stock Nutrition Specifications, and the Ross Parent Stock Performance Objectives.

Objective

To maximize welfare, reproductive potential (of both males and females), and chick quality by supplying a range of balanced diets that meet the requirements of broiler parent stock at all stages of their development and production.

Principles

Maintaining good uniformity and keeping close to body-weight targets is essential in feeding parent stock. Feed composition, feed form, feeding management, and general management must be considered together when assessing parent stock performance. Economic analysis of the whole broiler production cycle shows that small improvements in breeder or chick performance will cover the costs of improving nutrient levels in the breeder feed. In general, a high quality diet for the breeder is economically justified.

Broiler Breeder Nutrition

Feed formulation and feeding management are combined to achieve target body weights and good uniformity throughout the life of the breeder flock.

Nutrition is the major impacting variable upon both productivity and profitability in parent stock flocks and although the formulating and balancing of diets is a precision activity requiring specialist nutrition skills, farm managers should be aware of the nutritional content of their feeds. Such information can be obtained from the feed suppliers themselves or nutritional consultants. Most importantly, there should be farm level sub-sampling of diets and routine laboratory analysis to determine if expected dietary nutrient contents are being achieved. It is important that managers are aware of the make-up of the diet that is being fed to their stock to ensure that:

- Feed levels and consumption will provide adequate levels of daily nutrient intake (feed intake X nutrient concentration).
- There is proper and expected balance between feed nutrients.
- Routine laboratory analysis of diets can be usefully interpreted and correct actions taken such as:
 - Alerting the provider of a possibility of discrepant formulation.
 - Appropriate management of feeding programs.

Supply of Nutrients

Diets should be balanced on the basis of the intake of digestible nutrients. An excess or deficiency of any key nutrient will negatively impact total flock and progeny performance.

In practice, the supply of nutrients to parent stock is controlled through the nutrient composition of the feed and the level of feed intake, and these must always be considered together as changes in either one of these factors will impact on supply of nutrients. As daily supply (intake) of nutrients such as energy and amino acids are determinants of flock performance, the effect of changing either feed nutrient composition or feed allocation on nutrient intake must always be considered.

Guidelines for daily feed intakes, and for adjusting them according to observations of bird performance, have been discussed in earlier sections of this Handbook. These guidelines are made with reference to the dietary energy levels given in the recommended Parent Stock Nutrition Specifications: 11.7 MJ (2800 kcal) ME per kg for starter, grower and breeder diets.

While recommended nutrient specifications are given as dietary concentrations, it is the actuality of required daily nutrient intakes (i.e. the amount of nutrients that the bird requires in a day at any given time in its life) that should be considered when making feeding decisions. This is especially important when feed intakes may vary, such as when high temperatures result in lower feed intake.

Feed intake

Daily feed intakes per bird are influenced by both genetic and environmental circumstances. Control of feed supply is a major mechanism for effective flock management, and therefore feed intake expectations are important both to determining required diet nutrient density and to the taking of management decisions.

The daily bird requirement for a nutrient is satisfied by the product of presumptive feed intake and nutrient concentration. Recommendations for nutritional concentrations, as in the Parent Stock Nutrition Specifications, assume the achievement of feed intakes as given in the Parent Stock Performance Objectives.

Energy

Feed energy is now conventionally expressed as apparent metabolizable energy level corrected to zero nitrogen retention (AMEn); as these values are the more accurate description of energy value. Data on energy contents expressed in this way are available from many sources. In this Handbook, the term ME is used to describe AMEn.

Recommended feeding levels presented elsewhere in this Handbook and in the Parent Stock Performance Objectives assume diets to have energy concentrations of 11.7 MJ (2800 kcal) ME per kg for starter, grower and laying flocks. Because the bird responds to nutrient intake (not nutrient concentration), if diets have feed nutrient levels different from those assumed, then proportional changes in feed allowances must be made. For example, if birds are being fed a diet with 11.9 MJ (2844 kcal) ME per kg feed, then intake at peak should be reduced from 165 g to 162.4 g per bird per day to compensate for the increased energy in the diet ($11.7 \div 1.9 = 0.983$; $165 \times 0.983 = 162.2$).

The total daily energy need for a bird is the sum of energy required for maintenance, growth and production of egg mass. The maintenance energy requirement is by far the largest component of total energy need. Maintenance energy need is based on the bird's body weight and is significantly affected by environmental temperature. Total energy requirement will, therefore, vary with environmental temperatures, location and season. Adjustment of energy supply must therefore be based largely on observation of the birds' responses in body weight, body condition, feed clean-up time, and egg mass.

The choice of dietary energy level is a combination of feed management, welfare and economics. In particular circumstances, varying the feed energy level may be justified if feed intakes are not on target, or if economics dictate a change in feed energy level. If feed energy levels differ from those suggested in the recommended nutrition specification tables, then not only must feed allowance quantities be adjusted accordingly, but the concentrations of other nutrients in the diets must also be adjusted, in order to maintain a constant ratio of these nutrients to energy. These adjustments are necessary to ensure that the appropriate daily intake levels of required nutrients are achieved.

Adequate supply of energy is critical for optimal productivity and persistency. When energy supply appears to be the limiting factor (e.g. if production performance targets are not achieved), additional feed should be given. However, when a nutrient other than energy is limiting performance, the provision of additional feed may lead to excess energy intake - leading to excessive body-weight gain and improper ovarian development. If energy supply is adequate and another nutrient is too low, then the feed must be reformulated to give the properly required nutrient balance.

Energy contents of successive feeds should not vary widely. Feed changes should be gradual and carefully controlled; especially when changing diets (e.g. transition from Grower to Breeder rations).

Within a given diet, consistency in nutrient density and quality is critical. Ingredients which are variable in nutrient composition should be used with caution. Avoid large changes in feed ingredients and energy concentrations between deliveries to a given flock.

Protein and amino acids

Feed protein concentration must be sufficient to ensure that requirements for all essential amino acids are met. Amino acids provide the building blocks for body tissue, feather and egg protein, and for the replacement of proteins lost in the natural processes of daily protein turnover. Dietary protein content must provide amino acids at the optimum daily rate, ensuring they are in balance with one another and dietary energy.

Variation of feed protein content should be minimized. Excessive protein intake may lead to over-fleshing (increased breast meat deposition) and negatively affect fertility. In contrast, inadequate protein intake can lead to a reduction in egg size and feathering problems.

In general, it is preferable, especially under hot conditions, to feed readily digestible protein sources.

Specific nutrient recommendations are given in the Parent Stock Nutrition Specification documents. Amino acid levels are listed for those major essential amino acids which are most likely to be limited in practical feeds. The digestible amino acids are based on true fecal digestibility. Formulating diets on digestible amino acid provides a better balanced protein in the feed, which better meets the bird requirements. Crude protein and amino acids are given as total g per kg (for % divide by 10).

Macro minerals

The macro minerals calcium (Ca) and phosphorus (P) are critical for proper skeletal development, reproductive performance, shell quality, and other metabolic functions.

Laying hens require 4-5 g of calcium per hen per day (14-18 oz of calcium per 100 birds) to maintain calcium balance. In practice, this requirement is satisfied by feeding recommended breeder ration calcium levels no later than 5% egg production.

To maintain optimal shell quality, consider supplementing 1.0 g (0.03 oz) Ca per bird per day in the form of a large particle-sized limestone (diameter 3.2 mm [0.125 in]) or oyster shell. This is particularly relevant when feeding pelleted diets where finely ground limestone is often used in the diet as the calcium source to minimize pellet die wear. When birds are fed early in the day, the smaller particle-sized limestone in the feed is rapidly absorbed and excreted via the kidney long before the egg shell is laid down during the evening. Thus, provision of a larger particle calcium source during the afternoon can improve shell quality by ensuring calcium is present in the gut during shell formation. One effective way to provide this supplement is to evenly broadcast it on the house litter area. However, supplemental calcium sources should not be allowed to build up in the litter since excessive calcium intake can be detrimental to shell quality. If build up of the calcium supplement in the litter does occur, supplementation should be discontinued until the flock has consumed any calcium remaining in the litter. If mash feeds are used, large particle-sized limestone or oyster shell can easily be incorporated into the diet.

Adequate available phosphorus (P) intake is critical for skeletal structure and egg shell quality. Excessive levels of available P throughout lay reduce shell quality and have a negative impact on hatchery performance (hatchability). Feeding recommended available P levels will ensure adequate egg shell quality.

Levels of sodium, chloride, and potassium above required levels will increase water intake, reduce litter quality, and negatively effects egg shell quality. It is important to control dietary levels of these nutrients to avoid such problems occurring.

Phytase

The addition of phytase to the feed to release available P from plant materials and thus to partially replace the need for feed grade phosphates in the diet is common practice. If phytase is added to the diet it is important that it is used according to manufacturer recommendations, otherwise mineral-related deficiencies can occur.

Mineral imbalance and metabolic disorders

Calcium Tetany of broiler breeder hens is occasionally seen with mortality appearing from 25 to 30 weeks of age. Hens suffering from Calcium Tetany are found paralyzed or dead in the nest in the morning with active ovaries and an egg in the shell gland with a partially formed shell. No other pathology may be observed on post mortem. The occurrence of this condition is rare when the recommendations concerning feeding of calcium are followed.

Low available P and potassium (K) can lead to Sudden Death Syndrome (SDS). The SDS of broiler breeders occurs in early lay with birds dying suddenly in the breeder house. At post-mortem there is an enlarged flaccid heart, congested lungs, and pericardium in some birds. The SDS usually responds to K supplementation in the drinking water and increasing in the feed. Ross stock has a low susceptibility to SDS.

Added trace minerals

Recommended levels of supplementation for trace minerals in the premix can be found in the Parent Stock Nutrition Specifications. Generally speaking, organic chelated trace elements have higher biological availability than inorganic sources. When using inorganic sources of trace minerals, the sulfate form generally provides the highest biological availability.

Added vitamins

Vitamins are critical to all aspects of growth, reproductive performance and progeny. Under stressful conditions, disease outbreaks and other situations, birds can show a positive response to higher levels of certain vitamins. The goal should be to remove or reduce stress factors, rather than to depend on permanent use of excessive vitamin supplementation for optimal performance.

A major source of variation in supplementation for some vitamins is cereal type. Accordingly separate recommendations have been made for vitamin A, nicotinic acid, pantothenic acid, pyridoxine (B6), and biotin in maize versus wheat based feeds (see the Ross Parent Stock Nutrition Specifications for more details).

Vitamin potency is sensitive to many factors (e.g. moisture, trace minerals, and heat) which can reduce their shelf life. Quality control measures must be in place to ensure vitamin levels in the finished feed meet the recommended nutrient specifications. The time period for feed to go from the feed mill to being consumed by the breeder flock should be as short as possible. Feed deliveries should be scheduled so that feed does not reside in farm feed bins for excessive periods of time (i.e., >10 days). This is especially important under conditions of high temperature and humidity, which will accelerate overall feed quality degradation. By using appropriate mold inhibitor compounds (e.g. propionic acid based mold inhibitors), the risk of mold growth and subsequent mycotoxin production can be reduced.

Vitamin E is one of the most expensive vitamins and has several biological functions impacting the immune and reproductive systems so it is important to ensure that levels of this vitamin in the diet remain within recommended levels. Research has shown that recommended levels also enhance the immune system of newly hatched chicks. Recommendations for all vitamins are included in the Parent Stock Nutrition Specifications. Problems that can be caused by vitamin deficiencies are detailed in the Appendices at the back of the Handbook.

KEY POINTS

- Knowledge of the nutrient composition of the diet being fed is necessary to assure quality control of diet supply and to correctly manage feeding levels.
- Knowledge of dietary energy is especially important because nutritionists balance dietary nutrients to energy concentration. Feeding levels must be altered accordingly in response to changes in dietary energy concentration.
- Feed should not be stored on the farm and should be used within 10 days of delivery.
- Specific performance problems may be resolved by attention to concentrations of specific nutrients, but in general – provided diets are properly formulated – the greatest effects of diet upon performance are through non-optimum feed intake levels.

Feeding Programs and Diet Specifications

Feed specifications and feeding management must always be considered together. Different feed specifications may be used with equal success provided they lead, together with the feed management procedures, to the required bird performance. The main factors influencing feed specifications include available feed ingredients, feed processing technology, and bird management procedures.

Feeds should be formulated to meet nutrient specifications and be consistent over time. Sudden changes in feed ingredients and changes in other characteristics that may reduce feed intake, even transiently, should be avoided.

Feeding management and feed composition must be guided by close monitoring and observation of the flock.

The recommended and most widely used feed program consists of a Starter feed for about 28 days, a Grower feed up to 5% production, which is then followed by a Breeder Layer feed.

Starter period

A feature of successful breeder performance is to achieve proper early growth and physiological development. It is possible to achieve this with one Starter feed.

Starter feed should preferably be provided as a sieved crumb. Typically, the Starter feed will be fed for about 28 days.

Care should be taken to avoid presenting partially ground pieces of grain to the chicks that they can preferentially select from the diet. Individual chicks will select these large pieces, to the exclusion of the crumbles and consequently receive an imbalanced diet.

A Grower feed will follow immediately behind the Starter. This Grower feed will generally contain lower crude protein and amino acid specifications than the Starter to control body-weight gain.

During changes from Starter to Grower feed, body weight should be monitored carefully to safeguard against checks in growth. This is especially important when the change involves a change in feed ingredients and/or a change in feed form.

If problems are consistently experienced in achieving target body weights by 28 days (4 weeks), then feeding the Starter diet for another 1-2 weeks may be helpful.

Growing period

During the growing period, daily growth rates are low and nutrient requirements, when expressed as daily intakes, are small. However, it is important to maintain good feed quality in this period, and to avoid the use of poor quality feed ingredients.

During the growing period when feed volumes are lower, and where the feeding equipment does not distribute it throughout the house rapidly enough, flock uniformity can suffer. In such situations it may be necessary to lower the energy level of the grower feed to allow feed levels to be increased and to support good flock uniformity. If lower energy levels are used it is important that the ratio of other nutrients to energy are kept constant.

Several different feeding strategies can be followed to lead to successful production. For example, if photostimulating birds earlier than 21 weeks of age, it may be beneficial to use 4 diets (rather than 2) during the rearing phase. This will help to ensure that the birds receive adequate nutrients at the correct time in order to achieve an earlier onset of production. A 4-stage rearing program includes:

- Higher nutrient density Starter diet to support adequate early development – particularly for males.
- Second Starter diet to provide a smoother transition to a lower specification Grower diet.
- Lower density Grower diet to allow greater control of body-weight development and increase feed distribution during this period. Although the diet itself has a reduced concentration of nutrients per kg, the recommended feed intakes and increasing feed consumption over this phase of growth will ensure the required increase in daily nutrient supply.
- Prebreeder diet to provide higher amino acid and protein intake for adequate development of reproductive tissue.

Transition to sexual maturity

Sufficient amino acids and other nutrients are required for the proper development of reproductive tissues. Provision of supplemental vitamins in pre-lay and early lay periods will increase body tissue levels before egg production commences and may provide a benefit in early hatchability.

The laying stage

Feed compositions given in the recommended Nutrition Specification documents will support target levels of production in properly reared and uniform flocks. Performance during the laying stage is often affected by feeding and management practices applied during earlier stages of growth. Increasing feed allowances because of poor egg production should be undertaken with caution and a clear understanding of the flock's nutritional status.

In most flocks, using more than one breeder feed may not be nutritionally necessary. Slightly reduced daily requirements of amino acids are normally fully covered by feed intake reductions post-peak. Calcium requirement increases in older birds. This can be satisfied by providing a calcium supplement in the laying house instead of providing additional calcium in the feed.

Supplementary phosphorus may be provided if higher levels are needed in the earlier stages of lay to control SDS. Otherwise, available phosphorus levels should be kept at the recommended level.

An economic case can be made for a Breeder-2 ration with lower protein and amino acid and available phosphorus levels, and a higher calcium concentration. This is particularly true when supplemental calcium is not provided apart from the feed and when egg weights are too heavy.

Over-sized eggs are often associated with over-feeding. Therefore, it is prudent to evaluate all the elements of nutrient supply and feed intake levels if this is a problem.

Temperature effect on energy requirements

Environmental temperature is a major factor influencing energy requirement of the bird. As operating temperature differs from 20°C (68°F), energy intakes should be adjusted pro rata as follows:

- Increased by 0.126 MJ (30 kcal) per bird per day if temperature is decreased by 5°C from 20° to 15°C (68° to 59°F).
- Reduced by 0.105 MJ (25 kcal) per bird per day if temperature is increased by 5°C from 20° to 25°C (68° to 77°F).

The influence of temperatures above 25°C (77°F) on energy requirement is not as straight forward as the effect of cold. At temperatures above 25°C (77°F), feed composition, feed amount, and environmental management should be controlled to reduce heat stress. Providing correct nutrient levels and using feed ingredients with higher digestibilities will help to minimize the effect of heat stress. Increasing the proportion of the feed energy that comes from feed fats (rather than carbohydrates) may also be beneficial.

In addition to absolute temperature measurement, the effective temperature of birds can be monitored by measurement of bird performance against target and observation of bird behavior.

Male nutrition

Separate control of male feeding level using separate-sex feeding systems is essential for successful broiler breeder production. The use of a separate feed (a separate diet formulation with different nutrient concentrations) for males is not as clear-cut but may provide improvements in flock fertility.

The use of a single feed for both sexes is a widespread practice; however, the use of specific male diet in the laying period has been shown to be beneficial to the maintenance of male physiological condition and fertility. A separate male diet with lower protein and amino acid levels can prevent excessive breast muscle development, while adequate dietary supplementation of vitamin E and selenium (Se) are critical for sperm quality. The use of an organic chelated form of Se should be considered.

If a separate male diet is used, it should be introduced when birds are moved to the laying house or at light stimulation. When switching to a separate male diet, ensure caloric intake is not reduced if the male diet is lower in energy density than the diet currently being fed (dietary energy levels for a separate male diet should be between 10.9 and 11.7 MJ (2600 and 2800 kcal ME per kg).

KEY POINTS

- Birds respond to daily intakes of nutrients, therefore feeding programs (and feed levels) must relate to dietary nutrient content; especially energy and the nutritional requirements of the bird at a given age.
- Economic and management practices may demand flexibility in diet nutrient concentration, but in general variability in nutrient specification should be avoided.
- Nutritional problems will be observed as failures to achieve production and welfare targets and should be discussed with the nutritionists at the earliest opportunity.
- Diets need to be regularly sampled and the samples analyzed to ensure that the diet is as it should be.

Feed Manufacturing

Following good feed manufacturing practices will ensure that parent stock receive diets with adequate nutrient fortification, while minimizing potential contaminants. Unseen variations in feed ingredient quality and nutrient content are possible causes of bird failure to attain production targets. Frequent and routine control checks upon the physical quality and nutrient content of feed should therefore be completed.

Feeds should be regularly handled and examined by nose and eye (and if necessary microscope). Sub-sampling and analysis of feeds is essential to detection of anti-nutritional factors and ensuring that requirements for specific nutrients are being met.

Ingredient formulations, and their alteration with changing ingredient price, should be a subject for discussion with the feed manufacturer, and by close examination of declarations of ingredients and specifications.

- Raw material physical quality, ingredient nutritional content, and feed processing techniques must be of high standard and consistent from batch to batch for a given flock.
- Ingredients must be free of contamination by chemical residues, microbial toxins, pathogens, and mycotoxins.
- Raw materials should be as fresh as possible within practical limitations and should be stored under controlled conditions.
- Storage facilities must be protected from contamination by insects, rodents, and in particular, wild birds, all of which are potential carriers of disease.
- Breeding stock can be fed successfully on mash, crumbled or pelleted feed, as long as good feeding management is practiced.
- Provide feed as fresh as possible. The risk of nutrient degradation and mold growth in feed increases as a given feed delivery remains in the farm feed bin.

Alterations to the inclusion levels of specific diet ingredients – feedstuffs – are the major means by which feed manufacture can be optimized in terms of nutrient content, palatability, and price. A table is given in the Appendices which allows managers to assess the likely consequences of changes to feed ingredient inclusions upon the concentrations of diet nutrients.

Raw materials

Many feed ingredients are suitable for feeding to parent stock. Supply and price will usually determine the choice; however a few general guidelines may be given.

When comparing cereal sources, maize has been found to give performance advantages in the laying period when compared to wheat. Birds fed maize-based rations consistently have improved egg shell quality compared with hens fed wheat-based feeds. This leads to improved yield of hatching eggs, less bacterial contamination, and improved hatchability.

Feed fats and oils should be used at modest levels at all stages. In general, a minimum inclusion of 0.5-1.0 % added fat is recommended to reduce dustiness, improve absorption of fat soluble nutrients, and enhance palatability.

Feed processing

Breeding stock can be fed successfully on mash, crumbled or pelleted feed, as long as good feeding management is practiced. The feed form is highly dependent on available feed ingredients and feed compounding facilities.

Mash: A good quality mash extends clean-up time, compared to crumble or pellet forms, and therefore allows all birds the opportunity to eat the recommended feed amount. This will support good body weight development and uniformity. However, mash feed can be inconsistent due to segregation of low and high density feed ingredients as the feed is transported and conveyed onto the farm. Poor quality mash (e.g. that with a particle size that is too small) can increase the risk of mash bridging in farm feed bins.

Crumble: A good quality crumble will reduce clean-up time compared to mash, with a lower chance of segregation of the dietary ingredients compared to mash.

Pellets: A good quality pellet is preferred if clean-up time is a concern (e.g. during high environmental temperatures). If floor-feeding is applied, a good quality pellet is critical.

Feed hygiene (heat treatment)

All feed must be considered a potential source of bacterial infection for breeders, particularly coliforms and Salmonellae, and should be decontaminated if total bacterial pathogen control is required. Thermal processing involves treatment with adequate heat in a retention vessel at atmospheric pressure for sufficient time to kill the organism. Commonly, for parent stock feed this is around 86°C (191°F) for 6 minutes. This will generally reduce the total viable bacterial counts to less than 10 organisms per gram.

Pelleting alone will not completely eliminate harmful bacteria from feed (although it may reduce the contamination below detectable levels in tests of finished feed). Care must be taken not to re-contaminate feed. Critical control points for the prevention of re-contamination include the cooling, storage, and transportation of feed. Where feed thermal treatment is not available, safe and permitted additives can be a viable option.

When feeds are heated, consideration should be given to components that may be damaged by heat (e.g., vitamins and amino acids). The vitamin levels recommended in the Parent Stock Nutrition Specifications will cover losses from conventional conditioning and pelleting of the feed. However, more severe heat treatment may increase the need for vitamin and/or amino acid supplementation. There may also be changes (positive and negative) in nutritional value due to structural changes in the feed.

Finished feed

Quality control is essential. A program of monitoring the quality of finished feed is necessary, which should include both feed mill and farm sampling. It is assumed that feed manufacturing site personnel will take representative feed samples from production runs. At the farm level, it is useful to take and retain feed samples from each feed delivery. In the event flock performance problems occur, these samples are then available for additional analysis to help identify or exclude nutritional issues.

Samples should ideally be taken inside the house from one of the feed hoppers. Target a sample size of approximately 1,000 g (2.2 lbs). Place the sample in a sealable plastic bag and store in a cool, dry area until the flock is depleted.

Some of the consequences of not meeting the dietary nutrient specifications are summarized in **Table 25**.

Table 25: Consequences for the laying flock of not meeting the nutrient specifications.

	Effect of Undersupply	Effect of Oversupply
Crude protein	Depends on amino acid levels, but generally decreased egg size and number. Poor chick quality from young flocks.	Increased egg size and lower hatchability. Increased metabolic stress during hot weather conditions.
Energy	Body weight, egg size, and egg number will decrease unless feed quantity is adjusted.	Excess leads to increased double yolks, oversized eggs, and obesity. Late fertility/hatchability suffers.
Lysine, methionine & cystine	Decrease egg size and number.	
Linoleic acid	Decreased egg size.	
Calcium	Poor shell quality.	Reduced availability of nutrients.
Available phosphorous	May impair egg production and hatchability. Reduced bone ash in chicks.	Poor shell quality.

KEY POINTS

- Failure to achieve production targets can be due to unseen variations in feed ingredient quality and nutrient content.
- Quality control of the finished feed both at the feed mill and on farm is essential.
- Managers should be in constant dialogue with their feed nutritionist and their feed manufacturer to be aware of any changes made to ingredient formulation or nutrient specification.

Water

Water is an essential nutrient for life. Unlimited, clean, fresh water should be available to birds at all times when the birds are active. As a general rule in rear birds are consuming enough water when the ratio of water intake to feed intake is 1.6-1.8: 1 (water: feed - the lower ratio being for nipple drinkers, and the higher for bell type drinkers) at 21°C (69.8°F), but in lay, water intake may be expected to be slightly higher than this. Water requirement will vary with feed consumption and will increase with ambient temperature. Detailed information about drinker systems and water quality can be found elsewhere in the other sections of this Handbook.

KEY POINT

- Water is an essential ingredient for life, and birds should have unlimited access to clean, fresh water at all times when the birds are active.

Section 9 - Health and Biosecurity

Health and Biosecurity

Objective

To achieve hygienic conditions within the poultry house, and to minimize the adverse effects of disease. To attain optimum performance and bird welfare, and to provide assurance on food safety issues.

Principles

Hygienic conditions within the poultry house are achieved through the implementation of correct biosecurity, cleaning, and vaccination programs.

The Relationship Between Management, Disease Expression, and Bird Welfare

The incidence and severity of many diseases, and bird welfare, is affected by the degree of stress being experienced by the birds. The management systems described in this Handbook are designed to maximize production by optimizing bird welfare and minimizing stress in broiler parents. Where it may prove impossible to exclude a pathogen in a particular situation, the commercial effects of a disease may be minimized by reducing the stress deriving from other sources.

The overall balance of correctly applied management factors is important as many factors interact with each other to increase the symptoms seen as a result of infection. When defining control measures for disease, and therefore bird welfare, it is important to take into account the possible occurrence of stress or incidence of infections such as:

- Poor feed management and other stress factors that can precipitate problems of Staphylococcal or E.coli infections such as synovitis.
- Overstimulation of birds can be associated with peritonitis, increased double yolked eggs and polyclonal E.coli septicaemia at point of lay.
- Control of water supply to reduce unnecessary water leakage and/or poor litter management can cause problems with coccidiosis, staph arthritis/tendonitis, pododermatitis and poor egg hygiene.
- Stocking density, biosecurity, vaccination and control of immunosuppressive infections e.g. Marek's Disease, Reovirus, Infectious Bursal Disease (IBD), Chicken Anaemia Virus (CAV) and some mycotoxins, can markedly affect the severity of other diseases.

Hygiene Management

Strict operation of a comprehensive program of hygiene management is essential if proper attention is to be given to:

- Site biosecurity.
- Site cleaning.

Biosecurity

A good biosecurity program must be in place to prevent the introduction of disease organisms into the chicken flock.

Farm location/construction

- It is best to build the farm in an isolated area, at least 3.2 km (2 miles) distance from the nearest poultry or other livestock facilities that may contaminate the farm.
- Build the farm away from major roadways that may be used to transport poultry.
- Fence the perimeter of the farm to prevent unwanted visitors.
- Test the water source for mineral, bacterial and chemical contamination on a regular basis as water table/aquifers can change due to season, weather and agricultural activity.
- The design and construction of the houses should prevent wild birds and rodent from entering the building. A concrete foundation and floor will prevent rodents from burrowing into the house.
- Conventional broiler breeder houses should ideally be facing an East-West direction.
- Clear and level an area 15 m (50 ft) around all houses so that grass can be cut quickly and easily. Gravel or pebbles are easier to maintain than grass.

Preventing diseases transmitted by humans

- Minimize the number of visitors and prevent unauthorized access to the farm by locking the entry gates and posting no trespassing/no visitors signs.
- All people entering the farm should follow a biosecurity procedure. The requirement that all workers and visitors shower and use clean farm clothes is the best way to prevent cross contamination between facilities.
- Maintain a record of visitors, including name, company, purpose of visit, previous farm visited, and next farm to be visited.
- When entering and leaving each poultry house, workers and visitors must wash and sanitize their hands and boots.
- Tools and equipment carried into the house are a potential source of disease. Only necessary items should be taken in to the house and only after they have been properly cleaned and disinfected.
- If supervisory personnel are not able to avoid visiting more than one farm per day, they should visit the youngest flocks first. Always visit flocks with disease problems last. If a serious problem is suspected, like AI (Avian influenza), VVND (Viscerotropic velogenic newcastle disease), ILT (Infectious laryotracheitis), MG (Mycoplasma gallisepticum – Chronic Respiratory Disease), MS (Mycoplasma synoviae – Infectious Synovitis) or Salmonella all visits should be stopped immediately.

Preventing diseases transmitted by animals

- Whenever possible, place the farm on an “all in/all out” placement cycle. Multiple age chickens on the same site provide a reservoir for disease organisms.
- Downtime between flocks will reduce contamination of the farm. Downtime is defined as the time between completion of the cleaning/disinfection process and placing the next flock. A minimum downtime of 3 weeks between flocks is recommended, but the exact downtime required will depend on the size of the farm (a bigger farm may take longer to clean/disinfect).
- Keep all vegetation cut 15 m (50 ft) away from the buildings to provide an entry barrier to rodents and wild animals.
- Do not leave equipment, building materials or litter lying around. This will reduce cover for rodents and wild animals.
- Clean-up feed spills as soon as they occur.
- Store litter material in bags or inside a storage building or bin.
- Keep wild birds out of all buildings.
- Maintain an effective rodent control program (**Figure 120**). Baiting programs are most effective when followed continuously.
- Use an integrated pest management program, including mechanical, biological, and chemical controls.

Figure 120: Example of a rodent baiting plan. The actual number of baiting points placed must be appropriate to the risk.

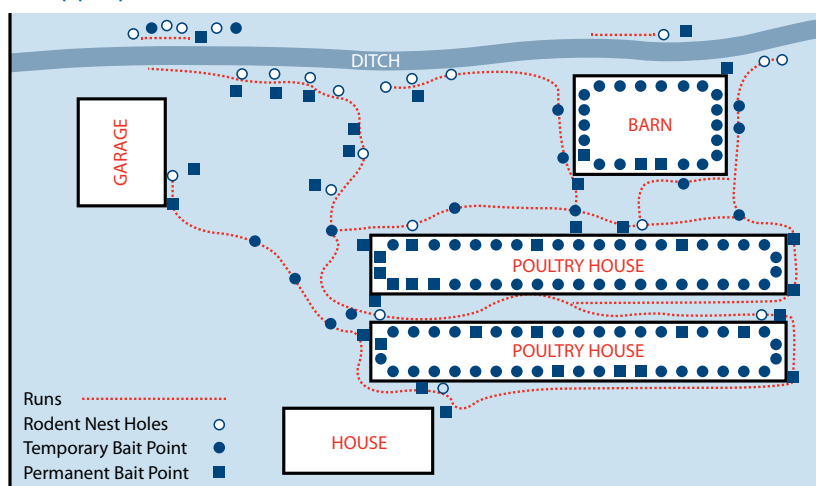

Site cleaning

Site cleaning must clean and disinfect the poultry house so that all potential poultry and human pathogens are removed and the numbers of residual bacteria, viruses, parasites and insects minimized between flocks. This will minimize any effect on health, welfare and performance on the subsequent flock.

House design

The house and equipment should be designed to enable easy, effective cleaning. The poultry house should have concrete floors, washable (i.e. impervious) walls and ceilings, accessible ventilation ducts and no internal pillars or ledges. Earth floors are impossible to clean and disinfect adequately. An area of concrete or gravel extending to a width of 1-3 m (3-10 ft) surrounding the house can discourage the entry of rodents and provide an area for washing and storing removable items of equipment.

Procedures

Planning: A successful cleanout requires that all operations are effectively carried out on time. Cleanout is an opportunity to carry out routine maintenance on the farm and this should be planned into the cleaning and disinfection program. A plan detailing dates, times, labor, and equipment requirements should be drawn-up prior to depleting the farm. This will ensure that all tasks can be completed successfully.

Insect Control: Insects are vectors of disease and must be destroyed before they migrate into woodwork or other materials. As soon as the flock has been removed from the house and while it is still warm, the litter, equipment, and all surfaces should be sprayed with a locally recommended insecticide. Alternatively the house may be treated with an approved insecticide within 2 weeks prior to depletion. A second treatment with insecticide should be completed before fumigation.

Remove dust: All dust, debris and cobwebs must be removed from fan shafts, beams, and exposed areas of unrolled curtains in open-sided houses, ledges and stonework. For best results use a brush so that the dust falls onto the litter.

Pre-spray: A knapsack or low-pressure sprayer should be used to spray a detergent solution throughout the inside of the house, from ceiling to floor, to dampen down dust before litter and equipment are removed. In open-sided houses, the curtains should be closed first.

Remove equipment: All equipment and fittings (drinkers, feeders, perches, nest-boxes, dividing pens etc.) should be removed from the building and placed on the external concrete area. It may not be desirable to remove automatic nest boxes and alternative strategies may be required.

Remove litter: All litter and debris must be removed from within the house. Trailers or rubbish skips (dumpsters) should be placed inside the house and filled with soiled litter. The full trailer or dumpster should be covered before removal, to prevent dust and debris blowing around outside. Vehicle wheels must be brushed and spray disinfected on leaving the house.

Litter disposal: Litter must not be stored on the farm or spread on land adjacent to the farm. It must be removed to a distance of at least 3.2 km (2 miles) from the farm, and disposed of in accordance with local government regulations in one of the following ways:

- Spread on arable crop land and plowed within 1 week.
- Buried in an approved 'landfill' site, quarry or hole in the ground. (In some areas this is not allowed).
- Stacked and allowed to heat (i.e. compost) for at least one month before being spread on livestock grazing land.
- Incinerated. (In some areas this is not allowed).
- Burning litter as a biofuel for electricity production.

Washing: Before washing starts check that all electricity in the house has been switched off. A pressure washer with foam detergent should be used to remove the remaining dirt and debris from the house and equipment. Many different industrial detergents are available and manufacturer's instructions should always be followed. The detergent used must be compatible with the disinfectant that will be used to disinfect the house later on. Following washing with detergent the house and equipment should be rinsed with clean fresh water, again using a pressure washer. Hot water should be used for cleaning and excess floor water removed using "squeegees" (a rubber-edged blade set on a handle, typically used for cleaning windows). Wastewater should be disposed of hygienically to avoid any re-contamination of the houses. All equipment, removed from the house must also be soaked, washed and rinsed. Cleaned equipment should then be stored under cover.

Inside the house, particular attention should be paid to the following places:

- Fan boxes.
- Fan shafts.
- Fans.
- Ventilation grills.
- Tops of beams.
- Ledges.
- Water pipes.
- Feed lines.

In order to ensure that inaccessible areas are properly washed, it is recommended that portable scaffolding and portable lights are used.

The outside of the building must also be washed and special attention given to:

- Air inlets.
- Gutters.
- Concrete pathways.

In open-sided housing, the inside and outside of curtains must be washed. Any items that cannot be washed (e.g. polythene, cardboard) must be destroyed.

When washing is complete, there should be no dirt, dust, debris, or litter present. Proper washing requires time and attention to detail.

Staff facilities should also be thoroughly cleaned at this stage. The egg store should be washed out and disinfected and humidifiers dismantled, serviced and cleaned prior to disinfection.

Cleaning water and feed systems

All equipment within the house must be thoroughly cleansed and disinfected. After cleansing it is essential that the equipment is stored under cover.

The water system: The procedure for cleaning the water system is as follows:

- Drain pipes and header tanks.
- Flush lines with clean water.
- Scrub header tanks to remove scale and biofilm deposit and drain to the exterior of the house.
- Refill tank with fresh water and add an approved water sanitizer.
- Run the sanitizer solution through the drinker lines from the header tank ensuring there are no air locks. Make sure the sanitizer is approved for use with the drinker equipment and is used at the correct dilution.
- Make up header tank to normal operating level with additional sanitizer solution at appropriate strength. Replace lid. Allow disinfectant to remain for a minimum of 4 hours.
- Drain and rinse with fresh water.
- Refill with fresh water prior to chick arrival.

Biofilms will form inside water pipes and regular treatment to remove them is needed to prevent decreased water flow and bacterial contamination of drinking water. Pipe material will influence rate of biofilm formation. For example, biofilm tends to form quicker on alkathene pipes and plastic tanks. The use of vitamin and mineral treatments in drinking water can increase biofilm and aggregation of materials to the pipes etc. Physical cleaning of the inside of pipes to remove biofilms is not always possible; therefore between flocks biofilms can be removed by using high levels (140 ppm) of chlorine or peroxygen compounds. These need to be flushed completely from the drinking system before birds drink. Cleaning may need to include acid scrubbing where the water mineral content (especially calcium or iron) is high. Metal pipes can be cleaned the same way but corrosion can cause leaks. Water treatment before use should be considered for high mineral waters.

Evaporative cooling and fogging systems can be sanitized at cleanout using a bi-guanide sanitizer. Bi-guanides can also be used during production to ensure that the water used in these systems contains minimal bacteria reducing bacterial spread into the poultry house.

The feed system: The procedure for cleaning the feed system is as follows:

- Empty, wash and disinfect all feeding equipment i.e. feed bins, track, chain, hanging feeders.
- Empty bulk bins and connecting pipes and brush out where possible. Clean out and seal all openings.
- Fumigate wherever possible.

Repairs and maintenance

A clean, empty house provides the ideal opportunity for structural repairs and maintenance to be completed. Once the house is empty, pay attention to the following tasks:

- Repair cracks in the floor with concrete/cement.
- Repair pointing (mortar joints) and cement rendering on wall structures.
- Repair or replace damaged walls, curtains and ceilings.
- Carry out painting or whitewashing where required.
- Ensure that all doors shut tightly.

Disinfection

Disinfection should not take place until the whole building (including the external area) is thoroughly cleaned and all repairs are complete. Disinfectants are ineffective in the presence of dirt and organic matter.

Disinfectants, which are approved by regulatory agencies for use against specific poultry pathogens of both bacterial and viral origin, are most likely to be effective. Manufacturers' instructions must be followed at all times.

Disinfectant should be applied using either a pressure-washer or a backpack sprayer.

Foam disinfectants allow greater contact time increasing the efficiency of disinfection. Heating houses to high temperatures after sealing can enhance disinfection.

Most disinfectants have no effect against sporulated coccidial oocysts. Where selective coccidial treatments are required, compounds producing ammonia should be used by suitably trained staff. These are applied to all clean internal surfaces and will be effective even after a short contact period of a few hours.

Formalin fumigation

Where formalin fumigation is permitted, fumigation should be undertaken as soon as possible after disinfection has been completed. Surfaces should be damp and the houses warmed to a minimum of 21°C (70°F). Fumigation is ineffective at lower temperatures and at relative humidities of less than 65%.

Doors, fans, ventilation grills and windows must be sealed. Manufacturers’ instructions concerning the use of fumigants must be followed. After fumigation, the house must remain sealed for 24 hours with **NO ENTRY** signs clearly displayed. The house must be thoroughly ventilated before anyone enters.

After clean litter has been spread, all the fumigation procedures described above should be repeated.

Fumigation is hazardous to animals and humans and is not permitted in all countries. Where it is permitted it **must be conducted by trained personnel following local safety legislation and guidelines**. Personal welfare, and health and safety guidelines must also be followed, and protective clothing (i.e. respirators, eye shields and gloves) must be worn. At least 2 people must be present in case of emergency.

In some situations, it may be necessary to use floor treatments as well. Some common floor treatments, their doses and indications, are given in **Table 26**.

Table 26: Common floor treatments for poultry houses.

Compound	Application Rate		Purpose
	kg/m ²	lbs/100 ft ²	
Boric acid	As necessary	As necessary	Kills darkling beetles
Salt (NaCl)	0.25	5	Reduction of clostridium counts
Sulphur powder	0.01	2	Lowers pH
Lime (calcium oxide/hydroxide)	As necessary	As necessary	Disinfection

Cleaning external areas

It is vital that external areas are also cleaned thoroughly. Ideally, poultry houses should be surrounded by an area of concrete or gravel, 1-3 m (3-10 ft) in width. Where this does not exist, the area around the house must:

- Be free of vegetation.
- Be free of unused machinery/equipment.
- Have an even, level surface.
- Be well drained and free of any standing water.

Particular attention should be paid to cleaning and disinfection of the following areas:

- Under ventilator and extractor fans.
- Under the feed bins.
- Access routes.
- Door surrounds.

All concrete areas should be washed and disinfected as thoroughly as the inside of the building.

Evaluation of farm cleaning and disinfection efficiency

It is essential to monitor the efficiency and cost of cleaning out and disinfection. The effectiveness of cleaning is commonly evaluated by completing Salmonella isolations, total viable bacterial counts (TVC) may also be useful. Monitoring trends in Salmonella /TVC's will allow continuous improvement in farm hygiene, and comparisons of different cleaning and disinfection methods to be made.

When disinfection has been carried out effectively, the sampling procedure should not isolate any Salmonella species. For a detailed description of where to sample, and recommendations of how many samples to take, please see your Aviagen veterinarian.

KEY POINTS

- A clear and implemented program of hygiene management should be in place for site biosecurity, and site cleaning and disinfection.
- Adequate biosecurity should prevent disease from entering the farm via both humans and animals.
- Site cleaning must cover both the interior and exterior of the house, all equipment and external house areas as well as the feeding and drinking systems.
- Reduce pathogen carryover by allowing adequate downtime between flocks for cleaning.
- Appropriate planning and evaluation of the cleaning and disinfection procedures must be in place.

Water Quality

Water should be clear with no organic or suspended matter. It should be monitored to ensure purity and freedom from pathogens. Specifically, water should be free from Pseudomonas species and Escherichia coli. There should be no more than one coliform/ml in any one sample and consecutive water samples must not contain coliforms in more than 5% of samples taken.

Water quality criteria for poultry are given in **Table 27**. If water comes from a main supply there are usually less water quality issues. Water from wells however, may have excessive nitrate levels and high bacterial counts, due to run-off from fertilized fields. Where bacterial counts are high, the cause should be established and rectified as soon as possible. Chlorination to give between 3 and 5 ppm free chlorine at the drinker level is usually effective in controlling bacteria but this is dependent on the type of chlorine component used.

Ultraviolet light (applied at the point of entry to the house) can also be used to disinfect water. Manufacturers' guidelines should be followed in establishing this procedure.

Hard water or water with high levels of iron (>3 mg/L) can cause blockages in drinker valves and pipes. Sediment will also block pipes and, where this is a problem, water should be filtered using a 40-50 micron (µm) filter. Water containing high levels of iron can support bacterial growth, and should not be used to wash or sanitize eggs.

A total water quality test should be done at least once a year, and more often if there are perceived water quality issues or performance problems. After house cleaning and prior to chick delivery, water should be sampled for bacterial contamination at the source, the storage tank and the drinker points.

Table 27: Water quality criteria for poultry

Criteria	Concentration (ppm)	Comments
Total Dissolved	0-1000	Good
Solids (TDS)	1000-3000	Satisfactory: Wet droppings may result at the upper limit
	3000-5000	Poor: Wet droppings, reduced water intake, poor growth and increased mortality
	>5000	Unsatisfactory
Hardness	<100 Soft	Good: No problems
	>100 Hard	Satisfactory: No problem for poultry but can interfere with effectiveness of soap and many disinfectants and medications administered via water
pH	<6	Poor: Performance problem, corrosion of water system
	6.0-6.4	Poor: Potential problems
	6.5-8.5	Satisfactory: Recommended for poultry
	>8.6	Unsatisfactory
Sulphates	50-200	Satisfactory: May have a laxative effect if Na or Mg >50ppm
	200-250	Maximum desirable level
	250-500	May have a laxative effect
	500-1000	Poor: Laxative effect but birds may adjust, may interfere with copper absorption, additive laxative effect with chlorides
	>1000	Unsatisfactory: Increases water intake and wet droppings, health hazard for the young birds
Chloride	250	Satisfactory: Highest desirable level, levels as low as 14ppm may cause problems if sodium is higher than 50ppm
	500	Maximum desirable level
	>500	Unsatisfactory: Laxative effect, wet droppings, reduces feed intake, increases water intake
Potassium	<300	Good: No problems
	>300	Satisfactory: Depends upon the alkalinity and pH
Magnesium	50-125	Satisfactory: If sulphate level >50ppm magnesium sulphate (laxative) will form
	>125	Laxative effect with intestinal irritation
	350	Maximum
Nitrate Nitrogen	10	Maximum (sometimes levels of 3 mg/L will affect performance)
Nitrates	trace	Satisfactory
	>trace	Unsatisfactory: Health hazard (indicates organic material fecal contamination)
Iron	<0.3	Satisfactory
	>0.3	Unsatisfactory: Growth of iron bacteria (clogs water system and bad odor)
Fluoride	2	Maximum
	>40	Unsatisfactory: Causes soft bones
Bacterial Coliforms	0 cfu/ml	Ideal: Levels above indicates fecal contaminations
Calcium	600	Maximum level
Sodium	50-300	Satisfactory: Generally no problem, however may cause loose droppings if sulphates >50ppm or if chloride >14ppm

Note: 1 ppm approximates to 1 mg.

KEY POINTS

- Good water quality is essential for bird health and welfare.
- Water quality should be routinely tested for bacterial and mineral contamination, and necessary corrective action taken based on the test results.

Dead Bird Disposal***Disposal pits***

- Burying in pits is one of the traditional methods of dead bird disposal but is now illegal in many countries.
- Advantages: Disposal pits are inexpensive to dig and tend to produce a low amount of odor.
- Disadvantages: Disposal pits can be a reservoir for diseases and they require adequate drainage.
- Ground water contamination is also a concern.

Incineration

- Advantages: Incineration does not contaminate ground water or produce cross contamination with other birds when grounds are properly maintained. There is little by-product to remove from the farm (ash).
- Disadvantages: This method of disposal tends to be more expensive and may produce air pollution. In many areas air pollution regulations have been established limiting incinerator use.
- If incinerators are used, be sure there is sufficient capacity for future farm needs.
- When operating, be sure carcasses are completely burned to a white ash.

Composting

- Composting has become one of the preferred alternatives for on-farm disposal in some countries.
- Advantages: It is economical and if designed and managed properly, will not contaminate the ground water or air.

Rendering

- In some countries, transporting dead birds to a rendering plant is the only approved method of dead bird disposal.
- Advantages: There is no on-farm disposal of dead birds, it requires minimal capital investment, and produces minimal environmental contamination. The product from dead birds can be recycled or converted into material, including a feed ingredient for other appropriate livestock.
- Disadvantages: It requires freezer units to keep the birds from decomposing during storage. It also requires intense biosecurity measures to prevent the transportation personnel from spreading diseases from the rendering plant or other farms to your farm.

KEY POINT

- Dead birds should be disposed of in a manner that avoids contamination of the environment, prevents cross contamination with other poultry, is not a nuisance to neighbors and is in accordance with local legislation.

Health Management

Disease control

Good management practices and high standards of biosecurity will prevent many poultry diseases. One of the first signs of a disease challenge is a decrease in water or feed intake (i.e. increased feed clean-up time). It is, therefore, good management practice to keep daily records of feed and water consumption. If a problem is suspected, immediate action should be taken by sending birds for post mortem examination and contacting the flock veterinary adviser. Early appropriate treatment of a disease incident may minimize the adverse effects on the birds' health, welfare, and reproductive performance and also minimize the effects on the health, welfare, and quality of the progeny.

Records are an important means of providing objective data for the investigation of flock problems. Vaccinations, batch numbers, medications, observations, and disease investigation results should all be recorded in flock diaries.

Vaccination

Vaccination provides the bird with exposure to a form of the infectious organism (antigen) to promote a good immunological response. This will actively protect the bird from subsequent field challenge and/or provide passive protection, via maternally derived antibody, to the progeny.

Vaccination programs

Common diseases, including Marek's Disease (MDV), Newcastle Disease (ND), Avian Encephalomyelitis (AE), Infectious Bronchitis (IB), Infectious Bursal Disease (IBD) (i.e. Gumboro Disease), should be routinely considered when a vaccination program is prepared. However, vaccination requirements will vary depending on local challenges, vaccine availability and local regulations. A suitable program should be devised by local flock veterinary advisers, who will use their detailed knowledge of the disease prevalence and intensity in a specific country, area or site.

Dyes, vaccine titres, and the elimination of clinical signs of disease can be used to assess the effectiveness of vaccines and vaccine delivery. It should be noted that titres are not always correlated with protection but are still useful when trying to evaluate the vaccination program. Excessive vaccination may lead to poor titres and/or coefficient of variation (CVs) of titres. Overly aggressive vaccination programs can also be stressful on growing chickens especially from 10-15 weeks of age (so try to minimize bird handlings when possible). The field situation should also be considered in evaluating the effectiveness of a vaccination program. Hygiene and maintenance of vaccination equipment is important and it is important to follow vaccine manufacturers instructions on methods of administration to get optimum results.

Vaccination can help prevent disease but is not a direct replacement for good biosecurity. Protection against each individual disease should be assessed when devising a suitable control strategy. For instance, 'all in/all out' policies provide good protection against Fowl Coryza and Infectious Laryngotracheitis (ILT), so that vaccination is unnecessary in some instances. The vaccines used in the vaccination program should be limited to those which are absolutely necessary; this will reduce costs, be less stressful, and provide greater opportunity to maximize the overall vaccine response. Vaccines should be obtained from reputable manufacturers only.

Types of vaccine

Vaccines for poultry are in 2 basic forms, killed or live. In some vaccination programs, they may be combined to promote maximum immunological response. Each type of vaccine has specific uses and advantages.

Killed Vaccines: These are composed of inactivated organisms (antigens), usually combined with an oil emulsion or aluminium hydroxide adjuvant. The adjuvant helps increase the response to an antigen by the bird's immune system over a longer period of time. Killed vaccines may contain multiple inactivated antigens to several poultry diseases. Killed vaccines are administered to individual birds by injection either subcutaneously or intramuscularly.

Live Vaccines: These consist of infectious organisms of the actual poultry disease. However, the organisms will have been substantially modified (attenuated) so that when they multiply within the bird they do not cause disease but do promote an immune response. Some vaccines are exceptional in that they are not attenuated and therefore require care before introduction into a vaccination program (e.g. some Coccidiosis vaccines).

In principle, when several live vaccinations are given for a specific disease, the most attenuated form of the vaccine is normally given first, followed by a less attenuated form where available. This principle is commonly utilized for ND live vaccination when pathogenic field challenge is anticipated.

Attenuated live vaccines are usually administered to the flock via drinking water, spray, and eye drop application or wing-web application. Occasionally live vaccinations are given by injection (e.g. Marek's Disease vaccine.)

Non-attenuated live vaccines are used in poultry vaccination programs. They are administered either via a route along which the pathogen would not normally enter (e.g. the wing web route with Fowl Pox) or by exposure to the vaccine during the period when disease does not occur (e.g. Chicken anaemia virus, CAV, exposure to birds during rearing).

Live bacterial vaccines for Salmonella and Mycoplasma vaccines are now available and may have a place in some production systems. Some competitive exclusion products (products consisting of healthy bacteria normally found in the gastrointestinal tract, which help to minimize colonization of undesirable harmful bacteria such as Salmonella) can also have a place in protecting parent stock from Salmonella and possibly other infections early in life, or after antibiotic treatment.

Combined live and killed vaccinations

The most effective method of achieving high and uniform levels of antibody to a disease is by the use of one or more live vaccines containing the specific antigen, followed by injection of the killed antigen. The live vaccines 'prime' the bird's immune system and facilitate a very good antibody response when the killed antigen is presented. This type of vaccination program is used routinely for many diseases such as IB (Infectious bronchitis), IBD, Reovirus (Reo) and ND. It ensures active protection of the bird and provision of high and uniform levels of maternally derived antibody. This allows passive protection of the progeny.

Specific vaccination programs

Vaccination programs must be designed according to local disease challenges and maternal antibody requirements in broilers. A suitable vaccination program should be established by the local veterinarian responsible for the health status of the operation. Veterinarians are available to provide suggestions or supportive information.

Marek's Disease virus

All broiler parent stock should receive Marek's Disease vaccine at day-old or 'In ovo' at the hatchery. There are 3 different serotypes of live Marek's vaccine available. Which vaccine(s) should be administered is dependent on the level of challenge in an area. The 2 most common serotypes are HVT (Turkey Herpes Virus) which is a serotype 3 and Rispen's which is a serotype 1. Rispen's is usually used in any high challenge areas, often in combination with other MDV vaccine serotypes. Combinations of different Marek's serotypes are often given for best protection depending on the challenge in the area the birds are to be placed.

Coccidiosis

Control of coccidiosis is important in broiler breeders. Vaccination of parent stock with live coccidiosis vaccines at the hatchery is now the method of choice for controlling this condition. In some cases birds are vaccinated on farm. Care should be taken to prevent subsequent exposure of the flock to substances with anticoccidial activity (except where recommended by the vaccine manufacturer). Post-vaccination management ensuring oocyst sporulation and re-infection is necessary to improve vaccine efficiency. Birds should be monitored by routine necropsies at specific ages (depending on the vaccine) to monitor for excessive reaction. Controlling vaccine reactions through good management and vaccine application is very important for good bird performance. Coccidiosis can also be controlled by the use of in-feed anticoccidial drugs.

Worm (helminth) control

It is important to monitor and control the internal worm burden (Helminth parasites) to which birds are exposed. A common program is for birds to receive 2 doses of an anthelmintic drug during the rearing period where required. Monitoring the efficiency of the control program through routine post mortem examination of birds can determine the necessity for an additional anthelmintic treatment at approximately 154 days (22 weeks) of age. Many anthelmintics should not be used when birds are in production as they might have negative effects on egg production and/or egg quality and fertility.

Salmonella and feed hygiene

Salmonella infection through contaminated feed represents a major threat to bird health. The risk of contaminated feed can be minimized by thermal processing of the feed and/or addition of feed additives with antimicrobial activity. Monitoring of raw materials will provide information about the degree of challenge coming through the ingredients into the diets.

Raw materials of animal origin and processed vegetable proteins are at high risk of salmonella contamination and their source and use in feeds for parent stock should be considered carefully.

Thermal processing of feed (e.g. conditioning, extending, pelleting) is used frequently to reduce bacterial contamination. An ideal goal is less than 10 enterobacteriaceae per gram of feed.

Antibiotics

Antibiotic administration must be for therapeutic use only, as a tool to treat infections, avoid pain and suffering, and preserve the welfare of the flocks. Antibiotics should be used only under the direct supervision of a veterinarian and records of all prescriptions should be kept.

KEY POINTS

- Good management and biosecurity will prevent many poultry diseases.
- Monitor feed and water intake for the first signs of a disease challenge.
- Respond promptly to any signs of a disease challenge by completing post-mortem examinations and contacting the local veterinarian.
- Vaccination alone cannot protect flocks against overwhelming disease challenges and poor management.
- Vaccination is most effective when disease challenges are minimized through well designed biosecurity and management programs.
- Vaccination should be based on local disease challenges and availability of vaccine.
- Monitor and control worm burden.
- Salmonella infection via feed is a threat to bird health. Heat treatment and monitoring of raw materials will minimize the risk of contamination.
- Only use antibiotics to treat disease and with veterinary supervision.
- Keep records and monitor flock health.

Health Monitoring Programs

Health monitoring programs have 2 purposes:

1. To confirm freedom from specific pathogens that can adversely affect the health, welfare, and performance of parent stock and the health, welfare, and quality of the progeny (broilers).
2. To identify the presence of disease at an early stage so that corrective measures can be implemented to minimize adverse effects either to the flock or the progeny.

Salmonella

Salmonella pullorum and *S. gallinarum* are strains which are specific to poultry. Control is monitored by detecting the presence of specific antibodies in blood using an agglutination test. This can be carried out either on the farm using whole blood or in the laboratory using serum. Many countries have official programs for the control and eradication of both *S. pullorum* and *S. gallinarum*. Both commercial and government supplies of specific antigen are available in many countries. The absence of these infections can also be monitored by microbiological surveys of the progeny and hatcheries.

The presence of *Salmonellae* is usually detected by bacteriological examination of the bird, the environment and the product as it proceeds through the hatchery. Many *Salmonellae* can affect both birds and humans (Zoonoses). *S. Enteritidis* and *S. typhimurium* are of particular importance and can readily be transmitted vertically to the broiler progeny. However, specific commercial ELISA tests for *S. Enteritidis* and *S. typhimurium* are available and can be used in a similar manner to the agglutination test for *S. pullorum* and *S. gallinarum*, to detect specific antibody in serum. Cull birds, cloacal swabs, fresh caecal droppings, litter, drag swabs/shoe covers, and dust samples have all been used to monitor flocks for the presence of *Salmonellae*. Hatchery samples include dead-in-shell, cull chicks, hatcher tray papers (where available), chick box liners, and hatchery fluff. Samples can be pooled, usually in tens, to facilitate practical processing through the laboratory. Many countries have official programs that include detailed culture methods and schedules for *Salmonellae*.

Mycoplasmosis

Blood samples taken from parent flocks should be monitored routinely for both *Mycoplasma gallisepticum* and *Mycoplasma synoviae* using the rapid serum agglutination test (RSAT) or specific, single or combined commercial ELISA tests. Confirmation can be conducted by PCR and/or culture. It should be noted that it is possible to get some false positive results with RSAT and Elisa tests, especially when monitoring day-old chicks.

Other diseases

Serological monitoring for the presence of other diseases can be carried out routinely or as is more common, following clinical signs and/or a drop in production. Serological monitoring for diagnostic purposes can include those diseases to which flocks have been previously vaccinated, e.g. ND, IB. Field challenge is suggested when a higher antibody response than normal has occurred in the flock.

Sampling for the presence of disease

Monitoring for most diseases in a population should be designed to detect a prevalence of at least 5%, with a 95% confidence. For those population sizes which normally apply to broiler parent flocks (i.e. >500 birds) approximately 60 samples should be taken when monitoring each flock. Traditionally, a higher level of monitoring is carried out prior to the onset of egg production at 140-154 days (20-22 weeks) of age, especially for *Mycoplasmas* and *Salmonellae* in parent flocks. Usually 10% or a minimum of 100 samples are tested at this critical time. The frequency of testing will vary with the individual disease and the requirements of local trading.

Trade between countries

Certification of freedom from specific avian pathogens is required when products from a flock, either eggs or day-old chicks, are traded between countries. The specific health requirements will vary from country to country.

Monitoring the effectiveness of vaccination programs

Vaccination programs provide both active protection to the bird and passive protection to the progeny by the provision of high, uniform levels of maternally derived antibody. Monitoring of vaccination programs is important and can be achieved by measuring the level of specific antibody in individual birds and by assessing the range of response in the number of birds sampled. Usually, a minimum of 20 blood samples per group are used and various quantitative serological tests have been used to quantify antibody response in vaccinated flocks. These tests include the haemagglutination inhibition (HI) test, agar gel diffusion (AGD) test, or the Enzyme Linked Immunosorbant Assay (ELISA) test. The ELISA test, is considered to be specific, sensitive and repeatable, and can be automated to enhance the efficiency of serological testing in a laboratory.

Serological evaluation should be scheduled around the vaccination program so a local database is developed. If changes occur in the vaccination program the monitoring program might also need to be changed accordingly. Each operation must develop its own baseline to facilitate interpretation of results.

Routine testing after killed vaccination (around point of lay) can allow maternal antibody to be predicted for the total period of lay. Cross-reactions in mycoplasma serology are commonly seen in birds for a 2-week period after the use of killed vaccines, so sampling around this time should be avoided.

Documentation and records

Records should be maintained for auditing and traceability. They should be clear, legible, and detailed enough to allow investigation into possible causes of poor quality, poor performance, morbidity, and mortality. Records may also be used as checklist by staff to ensure tasks are carried out.

KEY POINTS

- The effectiveness of the health and biosecurity programs in place must be routinely monitored and clear and detailed records must be in place.
- Appropriate corrective action must be taken if health monitoring procedures are found to be inadequate.

Appendices

Appendix 1: Records

Record keeping, and data analysis and interpretation, are an essential aid to effective management. Record keeping should be used in conjunction with target performance parameters. Records required to be kept are as follows:

REARING

Breed
 Source flock
 Hatch date
 Number of birds housed (male and female)
 Floor area and stocking density
 Feeder space per bird
 Drinker space per bird
 Feed/bird – daily, weekly and cumulative
 Mortality and culls – daily, weekly and cumulative
 Body weights, CV% and age of recording (male and female) – daily/weekly
 External and internal temperatures - minimum and maximum and operating (internal only)
 Water consumption – daily
 Water:feed ratio
 Sexing errors

LAYING

Breed
 Source flock
 Hatch date/date of housing
 Number of birds housed (male and female)
 Floor area and stocking density
 Mating ratio
 Eggs produced - daily, weekly, cumulative per bird
 Hatching egg number - daily, weekly, cumulative
 Floor eggs – daily, weekly and cumulative
 Feed - daily and cumulative
 Clean-up time
 Body weights (male and female) – daily/weekly
 Average egg weight - daily and weekly
 Egg Mass - daily and weekly
 Mortality and culls - daily, weekly and cumulative
 Hatchability
 Fertility
 External and internal temperatures - minimum and maximum and operating (internal only)
 Water consumption – daily
 Water:feed ratio
 Humidity
 Hours of light

TREATMENTS AND SIGNIFICANT EVENTS

Lighting program
 Feed deliveries
 Vaccination - date, dosage and batch number
 Medications - date, dosage and veterinary prescription
 Disease - type, date and number of birds affected
 Veterinary consultations - date and recommendations
 Cleaning and disinfection – materials and methods
 Bacterial counts after cleaning out (TVC)
 Incidents - equipment malfunction etc.

TARGET PARAMETERS

Weekly body weight - male and female
Egg production - number and weight
Hatching egg production
Hatchability and fertility
Weekly egg weight and egg mass

RECORDING SYSTEM

All essential records should be recorded in an appropriate recording system, which allows easy data recording, analysis and interpretation. Comprehensive data recording systems are freely available from Aviagen.

Appendix 2: Useful Management Information

STOCKING DENSITIES	
Rearing 0-140 Days (0-20 Weeks)	
Males Birds/m ² (ft ² /bird)	Females Birds/m ² (ft ² /bird)
3-4 (2.7-3.6)	4-7 (1.5-2.7)
Production 140-448 Days (20-64 Weeks)	
Males and Females Birds/m ² (ft ² /bird)	
3.5 - 5.5 (2.0-3.1)	

FEEDER SPACE PER BIRD		
Males Age	Track cm (in)	Pan cm (in)
0-35 days (0-5 weeks)	5 (2)	5 (2)
36-70 days (5-10 weeks)	10 (4)	9 (3.5)
71-140 days (10-20 weeks) - depletion	15 (6)	11 (4)
141 days-depletion (20 weeks –depletion)	20 (8)	13 (5)
Females Age	Track cm (in)	Pan cm (in)
0-35 days (0-5 weeks)	5 (2)	5 (2)
36-70 days (5-10 weeks)	10 (4)	8 (3)
71 days-depletion (10 weeks-depletion)	15 (6)	10 (4)

DRINKER SPACE		
	Rearing Period (0-15 Weeks)	Production Period (16 Weeks to Depletion)
Automatic circular or trough drinkers	1.5 cm (0.6 in)/bird	2.5 cm (1.0 in)/bird
Nipples	One/8-12 birds	One/6-10 birds
Cups	One/20-30 birds	One/15-20 birds

A GUIDE TO TYPICAL MATING RATIOS		
Age		Number of Males/100 Females (16 Weeks to Depletion)
Days	Weeks	
154-168	22-24	9.50-10.00
168-210	24-30	9.00-10.00
210-245	30-35	8.50-9.75
245-280	35-40	8.00-9.50
280-350	40-50	7.50-9.25
350-depletion	50-depletion	7.00-9.00

APPROXIMATE MINIMUM VENTILATION RATES PER BIRD		
Age	Cubic Meter Per Hour (CHM per Bird)	Cubic Feet Per Minute (CFM per Bird)
1-8 weeks	0.16	0.10
9-15 weeks	0.42	0.25
16 – 35 weeks	0.59	0.35
36 weeks - depletion	0.76	0.45

WATER TO FEED INTAKE RATIO
1.6 – 1.8 liters of water per kg of feed at 21°C (70°F)

Appendix 3: Conversion Tables

LENGTH	
1 meter (m)	= 3.281 feet (ft)
1 foot (ft)	= 0.305 meter (m)
1 centimeter (cm)	= 0.394 inch (in)
1 inch (in)	= 2.54 centimeters (cm)

AREA	
1 square meter (m ²)	= 10.76 square feet (ft ²)
1 square foot (ft ²)	= 0.093 square meter (m ²)

VOLUME	
1 liter (L)	= 0.22 gallon (gal) or 0.264 US gallons (gal US)
1 imperial gallon (gal)	= 4.54 liters (L)
1 US gallon (gal US)	= 3.79 liters (L)
1 imperial gallon (gal)	= 1.2 US gallons (gal US)
1 cubic meter (m ³)	= 35.31 cubic feet (ft ³)
1 cubic foot (ft ³)	= 0.028 cubic meter (m ³)

WEIGHT	
1 kilogram (kg)	= 2.205 pounds (lb)
1 pound (lb)	= 0.454 kilogram (kg)
1 gram (g)	= 0.035 ounce (oz)
1 ounce (oz)	= 28.35 grams (g)

ENERGY	
1 calorie (cal)	= 4.184 Joules (J)
1 Joule (J)	= 0.239 calories (cal)
1 kilocalorie per kilogram (kcal/kg)	= 4.184 Megajoules per kilogram (MJ/kg)
1 Megajoule per kilogram (MJ/kg)	= 108 calories per pound (cal/lb)
1 Joule (J)	= 0.735 foot-pound (ft-lb)
1 foot-pound (ft-lb)	= 1.36 Joules (J)
1 Joule (J)	= 0.00095 British Thermal Unit (BTU)
1 British Thermal Unit (BTU)	= 1055 Joules (J)
1 kilowatt hour (kW-h)	= 3412.1 British Thermal Unit (BTU)
1 British Thermal Unit (BTU)	= 0.00029 kilowatt hour (kW-h)

PRESSURE	
1 pound per square inch (psi)	= 6895 Newtons per square meter (N/m ²) or Pascals (Pa)
1 pound per square inch (psi)	= 0.06895 bar
1 bar	= 14.504 pounds per square inch (psi)
1 bar	= 104 Newtons per square meter (N/m ²) or Pascals (Pa) = 100 kilopascals (kPa)
1 Newton per square meter (N/m ²) or Pascal (Pa)	= 0.000145 pound per square inch (lb/in ²)

STOCKING DENSITY	
1 square foot per bird (ft ² /bird)	= 10.76 birds per square meter (bird/m ²)
10 birds per square meter (bird/m ²)	= 1.08 square feet per bird (ft ² /bird)
1 kilogram per square meter (kg/m ²)	= 0.205 pound per square foot (lb/ft ²)
1 pound per square foot (lb/ft ²)	= 4.88 kilograms per square meter (kg/m ²)

TEMPERATURE	
Temperature (°C)	= 5/9 x (Temperature °F - 32)
Temperature (°F)	= 32 + (9/5 x Temperature °C)

TEMPERATURE CONVERSION CHART	
°C	°F
0	32.0
2	35.6
4	39.2
6	42.8
8	46.4
10	50.0
12	53.6
14	57.2
16	60.8
18	64.4
20	68.0
22	71.6
24	75.2
26	78.8
28	82.4
30	86.0
32	89.6
34	93.2
36	96.8
38	100.4
40	104.0

OPERATING TEMPERATURE

Operating temperature is defined as the minimum house temperature plus 2/3 of the difference between minimum and maximum house temperatures. It is important where there are significant diurnal temperature fluctuations.

e.g. Minimum house temperature = 16°C
 Maximum house temperature = 28°C

Operating temperature = $[(28-16) \times 2/3] + 16 = 24^\circ\text{C}$

VENTILATION	
1 cubic foot per minute (ft ³ /min)	= 1.699 cubic meters per hour (m ³ /hour)
1 cubic meter per hour (m ³ /hour)	= 0.589 cubic foot per minute (ft ³ /min)

INSULATION

U value describes how well a building material conducts heat and is measured in Watts per square kilometer per degree centigrade (W/km²/°C).

R value rates the insulative properties of building materials, the higher the R value the better the insulation. It is measured in km²/W (or ft²/°F/BTU).

INSULATION	
1 square foot per degree Fahrenheit per British Thermal Unit (ft ² /°F/BTU)	= 0.176 square kilometers per Watt (km ² /W)
1 square kilometers per Watt (km ² /W)	= 5.674 square foot per degree Fahrenheit per British Thermal Unit (ft ² /°F/BTU)

LIGHT	
1 foot candle	= 10.76 lux
1 lux	= 0.093 foot candles

Appendix 4: Example of Manual Calculations for Grading

Figure 121 represents a house which has been split into 5 pens. The pre-grading population has been split between 4 pens, and 1 pen has been left empty from placement for the purpose of grading. The flock size is 8,400 birds and 2,100 birds are housed in each populated pen.

Figure 121: Pre-grade house set up with adjustable penning.

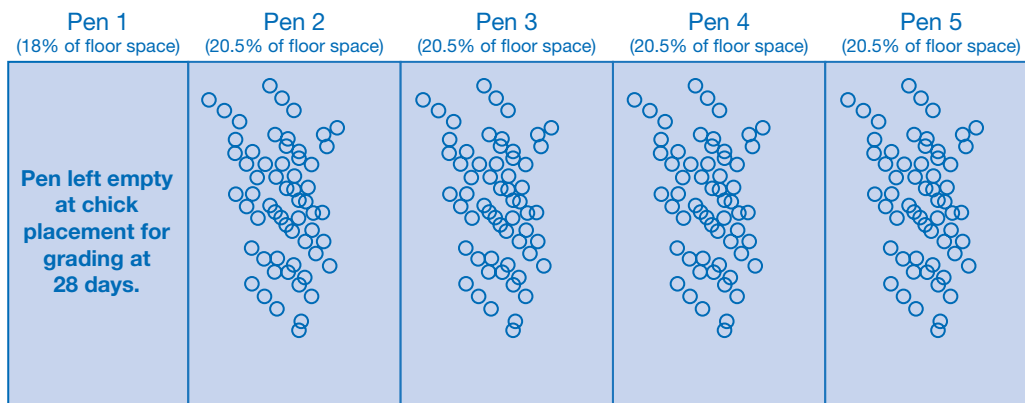

From each pen/population a random sample of birds should be caught and weighed. All birds caught in the catching pen need to be weighed to avoid selective weighing, but as a minimum the weights of 2% of the pen/population or 50 birds whichever is greater need to be recorded. In this example a total of 229 birds have been weighed.

All sample weights should be recorded on a body weight recording chart (**Figure 122**).

Figure 122: Manual body weight recording chart for a 3-way grade.

Bodyweight Recording Chart

FARM	BREED	HOUSE	PEN	SEX	AGE	DATE
		2		Female	28	Mar-15
NUMBER WEIGHED	AVERAGE WEIGHT	TARGET WEIGHT	% Coefficient of variation			
229	465 g (1.03 lbs)	450 g (0.99 lbs)	13.7			

WEIGHT POUNDS	WEIGHT GRAMMES	NUMBER OF BIRDS																													
		1	2	3	4	5	6	7	8	9	10	11	12	13	14	15	16	17	18	19	20	21	22	23	24	25	26	27	28	29	30
0.00	00																														
0.04	20																														
0.09	40																														
0.13	60																														
0.18	80																														
0.22	100																														
0.26	120																														
0.31	140																														
0.35	160																														
0.40	180																														
0.44	200																														
0.49	220																														
0.53	240																														
0.57	260																														
0.62	280																														
0.66	300	x	x	x	x	x																									
0.71	320	x	x	x	x	x	x	x	x	x																					
0.75	340	x	x	x	x	x	x	x	x	x	x																				
0.79	360	x	x	x	x	x	x	x	x	x	x																				
0.84	380	x	x	x	x	x	x	x	x	x	x	x																			
0.88	400	x	x	x	x	x	x	x	x	x	x	x	x																		
0.93	420	x	x	x	x	x	x	x	x	x	x	x	x	x																	
0.97	440	x	x	x	x	x	x	x	x	x	x	x	x	x	x																
1.01	460	x	x	x	x	x	x	x	x	x	x	x	x	x	x	x															
1.06	480	x	x	x	x	x	x	x	x	x	x	x	x	x	x	x	x														
1.10	500	x	x	x	x	x	x	x	x	x	x	x	x	x	x	x	x	x													
1.15	520	x	x	x	x	x	x	x	x	x	x	x	x	x	x	x	x	x	x												
1.19	540	x	x	x	x	x	x	x	x	x	x	x	x	x	x	x	x	x	x	x											
1.23	560	x	x	x	x	x	x	x	x	x	x	x	x	x	x	x	x	x	x	x	x										
1.28	580	x	x	x	x	x	x	x	x	x	x	x	x	x	x	x	x	x	x	x	x	x									
1.32	600	x	x	x	x	x	x	x	x	x	x	x	x	x	x	x	x	x	x	x	x	x	x								
1.37	620	x	x	x	x																										
1.41	640																														
1.46	660																														
1.50	680																														
1.54	700																														
1.59	720																														
1.63	740																														
1.68	760																														
1.72	780																														
1.76	800																														
1.81	820																														
1.85	840																														
1.90	860																														
1.94	880																														

Age	Metric	Imperial
Target Weight	28	28
Average Weight	450 g	0.99 lbs
Total Birds Weighed	465 g	1.03 lbs
Body Weight Range	229	229
	230 g	0.71 lbs

Table 28: F value for different sample sizes to be used in calculation of CV%

Sample Size	F Value	Sample Size	F Value
10	3.08	60	4.64
15	3.54	65	4.70
20	3.73	70	4.76
25	3.94	75	4.81
30	4.09	80	4.87
35	4.20	85	4.90
40	4.30	90	4.94
45	4.40	95	4.98
50	4.50	100	5.02
55	4.57	>150	5.03

From the sample, body weights CV% for the total population can then be calculated as:

$$CV\% = \frac{\text{weight range} * X 100}{\text{average body weight X 'F' value}}$$

$$CV\% \text{ (Metric)} = \frac{320 \times 100}{465 \times 5.03} = 13.7 \qquad CV\% \text{ (Imperial)} = \frac{0.71 \times 100}{1.03 \times 5.03} = 13.7$$

*Weight range is defined as the difference in weight between the lightest and heaviest birds.

The CV% is above 12 so a 3-way grade is required and the flock needs to be split in to 3 populations; light, normal and heavy. The approximate percentage of birds required in each of the 3 populations is 29% light birds, 57% normal and 14% heavy birds.

To determine the cut-off point for the lightest birds, (i.e. the weight below which birds are considered to be light) the following steps need to be taken;

1. The light population will be approximately 29% of the entire flock. Twenty-nine percent of the total number of birds weighed is 66 (29% of 229).
2. The lightest 66 birds are in the weight range of 300 to 439 g (0.66 to 0.97 lbs), shaded yellow in **Figure 122**.
3. A 'light' bird will therefore be anything less than or equal to 439 g (0.97 lbs) in weight.

This process needs to be repeated for normal and heavy birds. **Table 29** gives the cut off weights for each of the 3 populations (light, normal and heavy) based on the information given in **Figure 122**.

Table 29: Determination of cut-off weights for a 3-way grade based on the information given in **Figure 122**.

Category	% of Birds to be Included in Grading Category	Number of Birds for Determining Cut-off Weight (% x 229)	Weight Range g (lbs)	Chart Reference Color
Light	29	66	300-439 (0.66-0.97)	yellow
Normal	57	131	440-559 (0.97-1.23)	blue
Heavy	14	32	560-629 (1.23-1.39)	green

After the cut-off weights for each graded population has been determined, all birds in the flock should be weighed again and the light birds (any bird 439 g [0.97 lbs] in weight or below) and heavy birds (any bird 560 g [1.23 lbs] in weight or above) removed and graded into another pen. As there is now significant variation in the size of each graded population (29% light birds, 57% normal and 14% heavy birds), pen sizes will need to be adjusted to accommodate the new population numbers to equalize stocking density, feeder space, and drinker space (**Figure 123**).

Figure 123: Graded plan based on the body weight results from the body weight recording chart given in **Figure 122**.

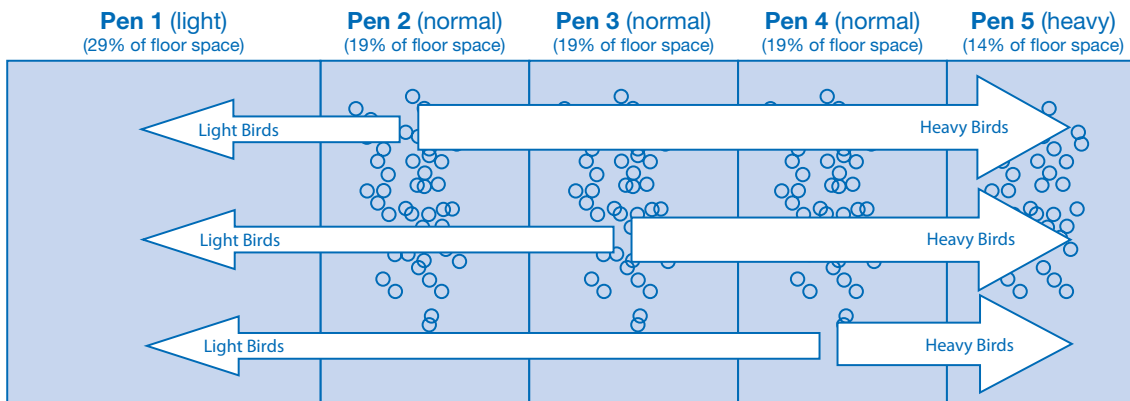

After grading a sample of birds should be reweighed from each population/pen (a minimum of 2% or 50 birds whichever is greater) and the average weight, CV% and number of birds established (**Figure 124**). The CV% for the graded populations will have been improved, but the overall flock CV% remain the same (**Figure 124**).

The 'normal' pens should be similar in weight and can be treated as one population. However, the farm manager should be aware of the average weight of each individual pen and any sudden deviations from the planned target should be investigated

The body weights from the graded populations should be plotted against target on a body weight target chart and the profile re-drawn where necessary to bring birds back onto target by 9 weeks (63 days) of age. Any adjustment in feed levels should be based on the deviation from target body weight.

Figure 124: Situation after a 3-way grade (adjustable penning).

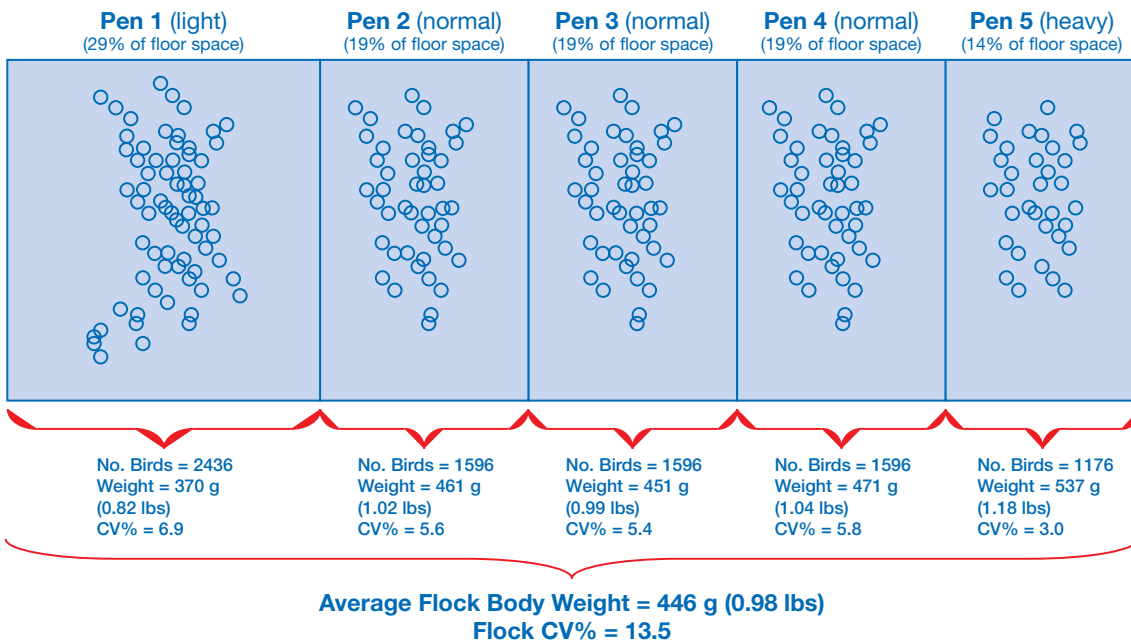

Appendix 5: Calculations for Ventilation Rates

Minimum Ventilation Calculation for Fan Timer Settings

Example (metric)

The assumptions on which this example calculation is based are given below. These will vary for individual circumstances.

Bird age = 20 weeks

Number of birds = 10,000

Minimum ventilation fan = 1 x 91 cm

Fan capacity (cubic meters per hour or cmh) = 15,300 m³/hr

Using a 5 minute cycle timer

Step 1: Calculate the total minimum ventilation rate required for the house (cubic meters per hour; cmh):

$$\begin{aligned} \text{Ventilation Rate} &= (\text{minimum ventilation per bird}) \times (\text{number of birds}) \\ &= (0.59 \text{ cmh per bird}) \times (10,000 \text{ birds}) \\ &= 5,900 \text{ cmh} \end{aligned}$$

Step 2: Calculate the percentage time the fans need to be running for:

$$\begin{aligned} \text{Percentage time} &= (\text{total ventilation needed}) \div (\text{total capacity of fans used}) \\ &= (5,900 \text{ cmh}) \div (15,300 \text{ cmh}) \\ &= 0.39 \text{ or } 39\% \end{aligned}$$

Therefore fans need to be run for 39% of the cycle time.

Step 3: Assuming a 5 minute timer is used, the run time required would then be 39% of 5 minutes or 117 seconds (1 minute 57 seconds).

Example (imperial)

Bird age = 20 weeks

Number of birds = 10,000

Minimum ventilation fan = 1 x 36 inches

Fan capacity (cubic feet per minute or cfm) = 9,000 cfm

Using a 5 minute cycle timer

Step 1: Calculate the total ventilation rate required for the house (cubic feet per minute; cfm):

$$\begin{aligned} \text{Ventilation Rate} &= (\text{minimum ventilation per bird}) \times (\text{number of birds}) \\ &= (0.35 \text{ cfm per bird}) \times (10,000 \text{ birds}) \\ &= 3,500 \text{ cfm} \end{aligned}$$

Step 2: Calculate the percentage time the fans need to be running for:

$$\begin{aligned} \text{Percentage time} &= (\text{total ventilation needed}) \div (\text{total capacity of fans used}) \\ &= (3,500 \text{ cfm}) \div (9,000 \text{ cfm}) \\ &= 0.39 \text{ or } 39\% \end{aligned}$$

Therefore fans need to be run for 39% of the cycle time.

Step 3: Assuming a 5 minute timer is used, the run time required would then be 39% of 5 minutes or 117 seconds (1 minute 57 seconds).

Calculation of number of fans required for tunnel ventilation

Example calculation (metric)

Assumptions:
 Bird age = 20 weeks
 Number of birds = 10,000

House width (W) = 12 m
 House height (H) = 2.4 m
 Roof height (R) = 1.5 m

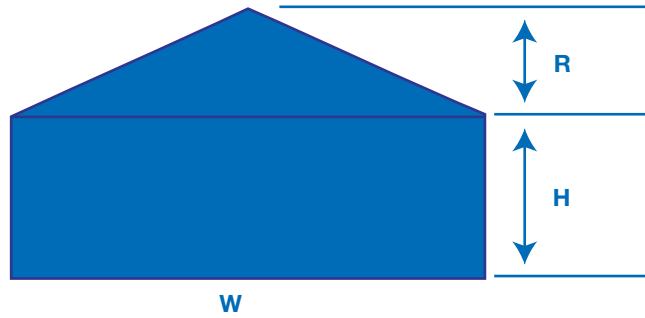

Design air speed (meters per second or m/s) = 2.03 m/s (rearing) & 2.54 m/s (production)
 Fan capacity at 0.15 inches of water column (cubic meters per hour or cmh) = 35,000 cmh
 Conversion of seconds to hours = 3,600
 Cross section area = $(0.5 \times W \times R) + (W \times H)$

Step 1: Determine the fan capacity required for a given air speed (cubic meter per hour; cmh):

$$\begin{aligned} \text{Required fan capacity} &= (\text{design air speed}) \times (\text{cross section area}) \times (3,600) \\ \text{Cross section area} &= (0.5 \times 12 \text{ m} \times 1.5 \text{ m}) + (12 \text{ m} \times 2.4 \text{ m}) = 37.8 \text{ m}^2 \\ \text{Required fan capacity} &= (2.54 \text{ m/s}) \times (37.8 \text{ m}^2) \times (3,600) \\ &= 345,643 \text{ cmh} \end{aligned}$$

Step 2: Determine the number of fans required:

$$\begin{aligned} \text{Number of fans} &= (\text{required fan capacity}) \div (\text{fan operating capacity}) \\ &= (345,643 \text{ cmh}) \div (35,000 \text{ cmh}) \\ &= 9.9 \text{ (10) fans} \end{aligned}$$

Example calculation (imperial)

Assumptions:
 Bird age = 20 weeks
 Number of birds = 10,000

House width (W) = 40 ft
 House height (H) = 7.9 ft
 Roof height (R) = 4.9 ft

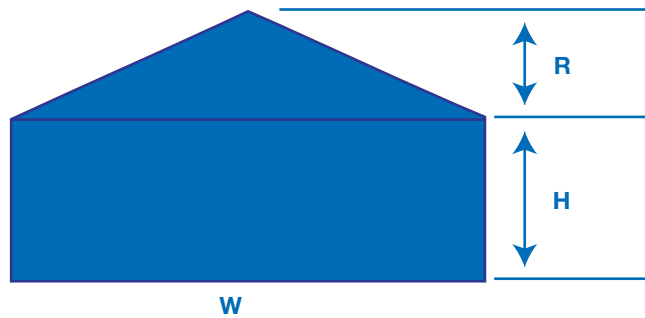

Design air speed (feet per minute or fpm) = 400 fpm (rearing) & 500 fpm (production)
 Fan capacity at 0.15 inches of water column (cubic feet per minute or cfm) = 20,585 cfm
 Cross section area = $(0.5 \times W \times R) + (W \times H)$

Step 1: Determine the fan capacity required for a given air speed:

$$\begin{aligned} \text{Required fan capacity} &= (\text{design air speed}) \times (\text{cross section area}) \\ \text{Cross section area} &= (0.5 \times 40 \text{ ft} \times 4.9 \text{ ft}) + (40 \text{ ft} \times 7.9 \text{ ft}) = 414 \text{ ft}^2 \\ \text{Required fan capacity} &= (500 \text{ fpm}) \times (414 \text{ ft}^2) \\ &= 207,000 \text{ cfm} \end{aligned}$$

Step 2: Determine the number of fans required:

$$\begin{aligned} \text{Number of fans} &= (\text{required fan capacity}) \div (\text{fan operating capacity}) \\ &= (207,000 \text{ cfm}) \div (20,585 \text{ cfm}) \\ &= 10.1 \text{ (10) fans} \end{aligned}$$

Calculation for evaporative cooling cool pad area

Example calculation (metric)

Assumptions:

Bird age = 20 weeks

Number of birds = 10,000

Pad air speed (meters per second or m/s) = 1.91 m/s (150 mm pad)

The house has ten 127 cm fans with a capacity of 35,000 cubic meters per hour (cmh)

Conversion of seconds to hours = 3,600

Step 1: Determine cooling pad area:

$$\begin{aligned}
 \text{Cooling pad area} &= (\text{tunnel fan capacity [cmh]} \div (\text{pad air speed [m/s]} \times 3600)) \\
 &= (10 \times 35,000 \text{ cmh}) \div (6876 \text{ m/h}) \\
 &= 50.9 \text{ m}^2
 \end{aligned}$$

Example calculation (imperial)

Assumptions:

Bird age = 20 weeks

Number of birds = 10,000

Pad air speed (feet per minute or fpm) = 375 fpm (6 inch pad)

The house has ten 50 inch fans with a capacity of 20,585 cubic feet per minute (cfm)

Step 1: Determine cooling pad area:

$$\begin{aligned}
 \text{Cooling pad area} &= (\text{tunnel fan capacity [cfm]} \div (\text{pad air speed [fpm]})) \\
 &= (10 \times 20,585 \text{ cfm}) \div (375 \text{ fpm}) \\
 &= 549 \text{ ft}^2
 \end{aligned}$$

Appendix 6: Dew Point or Condensation Table

When eggs are moved from a cold environment in to warmer, more humid conditions, they may sweat. The following table gives the shell temperature that will result in condensation when moving eggs into a wide variety of temperatures and humidities. To avoid condensation the egg shell temperature needs to be higher than that given in the table.

Eggs may sweat when they are transported from a cold egg store on the farm to a warm hatchery or from a cold egg store in the hatchery for pre-warming or incubation.

If eggs are sweating they should not be fumigated or put in to a cold egg store until they are dry.

Temperature at Which Eggs are to be Moved °C (°F)	Relative Humidity (%RH)					
	40	50	60	70	80	90
15 (59)					11	13
20 (68)			12	14	16	18
Pre-warming 23 (74)		12	15	17	19	21
25 (77)	10	13	16	19	21	23
30 (86)	14	18	21	24	26	28
35 (95)	18	21	25	28	31	33
Incubator	21	25	28	31	34	36
40 (104)	23	27	30	33	36	38

Appendix 7: Nutrient Composition of Some Commonly Used Feed Ingredients (Per Kilogram)

CP	Energy (ME)		Arginine		Iso-Leucine		Lysine		Methionine		Meth & Cyst		Threonine	Tryptophan	Ca	AvP	Na	Cl	K	Choline	Linoleic Acid	Dry Matter			
	g	kcal	T	A	T	A	T	A	T	A	T	A	T	A	g	g	g	g	g	g	g	g			
Barley	107	11.7	2790	5.4	4.5	3.0	3.8	3.0	1.8	1.4	4.2	3.4	3.6	2.7	1.2	0.9	0.6	1.4	0.1	1.0	4.8	990	8.6	880	
Maize	87	13.7	3275	4.1	3.8	3.0	2.7	2.4	1.8	1.7	3.7	3.3	3.1	2.7	0.6	0.5	0.3	0.9	0.1	0.5	3.6	620	18.8	880	
Wheat	119	12.7	3020	5.6	5.0	3.9	3.5	3.3	2.7	1.9	4.6	4.0	3.4	2.8	1.4	1.2	0.7	1.3	0.1	0.4	4.2	1000	6.8	880	
Sorghum	101	13.5	3215	4.0	3.4	4.0	3.3	2.3	1.8	1.5	3.6	3.0	3.4	2.6	1.1	0.9	0.4	0.9	0.1	0.7	3.8	660	12.2	880	
Oats	112	11.0	2620	7.5	7.1	4.2	3.7	4.8	4.2	1.9	1.7	5.1	4.3	3.9	3.3	1.3	1.1	1.7	0.1	0.7	4.7	950	16.8	880	
Maize Gluten Feed	209	8.0	1915	9.5	8.3	6.7	5.5	6.7	4.8	3.6	3.1	8.9	6.4	7.7	5.9	1.2	1.0	1.2	3.7	2.4	2.1	12.6	1510	17.2	890
Maize Gluten Meal	607	14.9	3565	19.5	18.8	25.1	24.1	10.3	9.3	14.5	23.7	25.5	23.7	21.0	19.6	3.2	3.1	0.4	1.8	0.1	0.5	1.6	330	16.3	890
Wheat Feed/Middlings	156	7.6	1825	9.5	8.2	4.1	5.6	4.6	2.6	2.0	5.7	4.3	5.0	3.7	1.9	1.5	1.0	2.9	0.3	0.3	13.7	1440	14.0	870	
Wheat Bran	150	6.2	1475	10.1	7.8	4.6	3.5	6.0	4.4	2.3	1.7	5.5	4.0	4.9	3.6	2.1	1.4	1.9	3.5	0.4	1.3	12.5	1230	14.0	870
Rice Bran Raw	129	9.9	2370	10.3	8.9	4.4	3.7	6.0	4.8	2.7	2.2	5.6	4.7	5.0	4.1	1.6	1.2	1.0	2.5	0.1	0.4	10.6	1130	38.5	890
Rice Bran Ext.	147	6.8	1610	11.6	10.0	5.2	3.8	6.5	4.8	3.2	2.5	6.4	4.5	5.9	4.1	1.7	1.3	1.4	2.8	0.2	0.7	12.1	1230	3.6	890
Field Beans (White)	300	11.2	2665	28.6	26.6	11.8	10.1	18.8	16.5	2.3	1.8	5.9	4.6	10.1	8.9	1.7	1.4	1.1	2.3	0.2	0.7	13.4	1670	5.2	870
Peas	227	11.4	2715	21.4	19.7	8.8	8.0	15.7	13.5	2.3	1.9	5.6	4.2	8.1	6.9	2.0	1.6	1.1	1.8	0.1	0.6	11.0	642	4.0	870
Soybeans, Heated	356	14.4	3450	26.3	22.9	16.2	14.1	22.4	19.3	5.4	4.7	10.9	9.2	14.2	12.1	4.9	4.2	2.3	2.2	0.1	0.3	17.6	2860	97.0	880
Soybean Meal, 48	473	9.3	2230	34.6	32.2	21.3	19.5	29.3	26.7	6.8	6.3	13.8	12.1	18.6	16.6	6.1	5.2	2.7	2.7	0.2	0.3	22.6	2730	7.0	870
Sunflower Meal, 39	386	6.7	1600	33.3	31.6	16.3	15.0	13.8	12.0	9.2	8.5	16.1	14.2	14.6	12.7	4.8	4.1	3.7	2.9	0.3	1.2	14.7	2890	6.8	900
Rape/Canola Meal	343	7.1	1700	20.8	18.7	13.4	11.4	19.2	15.4	6.9	6.1	15.6	12.7	15.1	12.1	4.5	3.7	7.3	3.6	0.3	0.3	12.6	6700	3.1	880
Fish Meal 66	660	13.6	3250	38.1	35.0	27.4	25.2	51.4	45.7	18.9	17.0	24.8	21.6	28.0	25.2	7.0	6.2	34.9	17.6	10.3	15.8	10.0	3050	0.1	910
Herring Meal	706	14.1	3360	40.4	37.1	30.0	27.6	56.3	50.1	20.7	18.6	27.0	23.5	30.5	27.4	7.8	7.0	26.4	15.5	10.3	16.2	13.9	5300	0.1	910
Meat and Bone Meal	538	12.6	3000	37.7	29.4	16.1	12.9	29.6	22.5	8.1	6.6	14.0	9.9	18.8	14.0	3.6	2.5	73.3	22.6	7.6	6.3	4.8	1900	8.1	940

Notes

T=Total amino content; A=Available amino acid content

These data are given as a guide to feed formulation. Local information on the actual quality of available ingredients should always be used in preference.

Data are based on information published by Degussa AG; CVB, Netherlands; National Research Council, USA.

Meat and Bone Meal is a very variable product and is increasingly excluded from breeder feeds on the grounds of biosecurity. Data relate to a sample with 54% protein, 14% fat and 23% ash.

Appendix 8: Trouble Shooting - Vitamin Deficiency

Possible Cause	Problem							
	Egg Production	Fertility	Hatchability	Resistance to Disease	Feathering	Bone Deformities	Leg Weakness	Thin Shell Eggs
Vitamin A	X		X	X	X		X	
Vitamin D3	X		X			X		X
Vitamin E	X	X	X	X				
Vitamin B12	X		X					
Riboflavin			X	X			X	
Niacin					X	X		
Pantothenic Acid			X	X	X			
Choline	X					X		
Vitamin K								
Folic Acid	X		X		X	X		
Thiamin B1								
Pyridoxine B6	X		X					
Biotin	X	X	X		X	X	X	

Appendix 9: Additional Sources of Management Information

Additional sources of specific management information can be obtained from the following publications. These publications are available online at www.aviagen.com or by emailing a request to info@aviagen.com.

- Environmental Management in the Broiler Breeder Rearing House
- Environmental Management in the Broiler Breeder Laying House
- Water Quality
- Ross 308 Parent Stock Performance Objectives
- Ross 308 Parent Stock Nutrition Specifications
- Ross 708 Parent Stock Performance Objectives
- Ross 708 Parent Stock Nutrition Specifications
- Investing Hatchery Practice
- Hatchery Maintenance
- Hatchery How To's

Keyword Index

Activity	87	Disposal of dead birds	151
Air flow/speed	112, 114, 115, 117, 169	Distribution curves	29
Air inlet	114	Distribution of birds when feeding	24
Air leakage/tightness	109, 112, 113	Downtime	144
Air quality	20, 113	Drainage	108
Airborne disease	108	Drinker space	27, 48, 159
Alertness	65, 86-88, 93	Drinkers	13, 16, 17, 27
All-in/all-out	12, 144, 152	Drinker height	26, 27, 58,
Amino Acids	135, 142	Dust	13, 145
Anti-nutritional factors	140	Egg collection	58, 102
Antibiotics	154	Egg disinfection	103
Antibody	156	Egg packing	102
Automated feeding	25	Egg production	10, 59, 70, 72
Automatic weigh scale	78	Egg selection	102
Bacterial counts	103	Egg weight	61-63, 70-72, 74
Behavior	20, 21, 52, 115, 117	Electronic weigh scales	31, 78, 82
Biofilms	147	ELISA	156
Biosecurity	12, 107, 110, 143, 149, 152, 156	Energy	49, 69, 134, 139, 142
Blackout	121, 124	Environment	10, 23, 109, 134
Body condition	60, 65, 85, 86, 88-91, 94-97	Evaporative cooling	119, 170
Body-weight targets	31, 33, 42, 43, 48, 69, 83, 122, 126, 128, 130, 165	F value	165
Body weight	31, 67, 70-72, 74, 76, 82, 87, 97	Fans	115, 116, 118, 168, 169
Breast shape	88, 89, 96	Farm design	107, 108, 144
Brooding	11, 14, 15, 17, 110, 121	Fat pad	96, 97
Calcium	135	Fats and oils in diets	140
Chick placement	10-12, 16	Feathering	65, 87, 93
Chick weighing	79	Feed allocation	9, 14, 17, 25, 26, 59, 60, 63, 67, 69, 73, 75, 138, 152
Chloride	136	Feed hygiene	141, 154
Chlorination	27, 149	Feed level	36, 39, 43-45, 50, 71, 72, 74, 75, 76, 134
Clean-up time (feed)	25, 61, 69	Feed manufacture	133, 140
Cleaning eggs	104	Feed quality	26, 61, 140
Cleaning of house and site	12, 145, 146, 148, 149	Feed specifications	137, 138
Coccidia	148, 154	Feed storage	26, 137, 140
Coefficient of variation (CV)	29, 39, 80, 82, 166	Feed systems	51
Coliforms	149	Feed texture	61
Comb and Wattles	51, 92	Feed-bin location	110
Condensation	105	Feeder height	25, 51, 56, 58
Condition of birds	60, 65, 85, 86, 88-91, 94-97	Feeder space	24, 48, 56, 159
Contamination of egg	101	Feeding behavior	54
Contamination of feed	141	Feeding equipment	16, 54, 56
Controlled environment housing	112, 121	Feeding management	10, 25, 58, 133, 137, 138
Conversion tables	161, 162	Feedstuffs	140, 172
Cooling of egg	101	Feet	87
Cooling of house	119, 169	Fertility	65, 88
Critical age objectives	6	Filter, water	149
Crop fill	22, 50	Fines	26
Crumb	14, 25, 137, 141	First egg	57, 68
CT scanning	89, 96	Fleshing	85, 88, 95
Curtains	111	Floor eggs	58, 102
Daylength	121-125, 127-129	Floor feeding	25
Dead bird disposal	151	Floor space	23, 32
Dew point table	171	Floor hygiene	148
Diet formulation	140	Fogging	17, 119
Direction plates	114	Footpad	76, 87, 92
Dirty eggs	104, 106	Formaldehyde	103
Disease	13, 152, 155	Formalin	148
Disinfection	12, 13, 103, 145, 147, 149	Fumigation	103, 147, 148

Grading	10, 12, 29, 30, 32, 35, 36, 38, 41, 164, 166, 167	Open-sided housing	121, 124-126
Grill feeder	54, 55	Operating temperature	163
Grower feed	137	Out-of-season flocks	125, 128-130
Growth	9, 68, 77	Over-mating	65
Handling	10	Overweight birds	43, 45, 49, 64
Hard water	149	Pad cooling	119
Hatchability	55, 65, 97, 99, 103, 105, 140, 142	Pan feeder	24, 55
Hatching eggs	99, 103	Pathogens	149
Head of bird	87, 92	Peak production	44, 48, 58, 59, 67, 68, 75
Health monitoring	155	Pellet	14, 25, 141
Heat treatment of feed	141	Pen size	35, 36, 42, 166
Heating equipment	14, 110	Penning layout	30-42, 167
Heavy birds	34, 41	Perches	28, 58
House design	12, 109, 144, 145	Perimeter	144
Humidity	13, 17, 18, 19, 105, 120	Persistence	135
Hygiene	13, 143	Pest management	144, 145
Immunological response	152	Phosphorus	135
Incineration	151	Photorefractory	121, 124, 127
Infection	143	Photostimulation	9, 121, 122
Inlets	114	Physical assessment of bird	85
In-season flocks	130	Phytase	136
Insect control	145	Pin (pelvic) bones	57, 94
Insulation	109, 163	Placement	11
Keel bone	90	Platform weighing	82
Laboratory analysis of feed	133	Population variation/uniformity	29, 30
Lamp type	131	Post-peak management	67
Legs and feet	92	Potassium	136
Light birds	32, 35, 41	Potency of vitamins	136
Light leakage	122, 124	Power back-up	108
Light spectrum	131	Pressure	112
Lighting programs	14, 17, 57, 121-125, 128, 129	Profiles for body weight	44, 49, 123, 130
Lighting	50, 58, 109, 121, 163	Protein	135, 142
Limestone	135	Quality control of feed	142
Litter	13, 76, 146	Random sampling	31, 33, 37, 40, 50, 85, 164
Male feeding	56, 64	Raw material quality	140
Management of disease	143	Re-circulation fans	111
Managing to condition	85-94	Rear	9
Manometer	113	Rear and move	50
Manual feeding	25	Records	72, 81, 152, 156, 157
Marek's disease	153	Regulations	11
Mash	141	Relative humidity	13, 171
Mating	51, 58, 64-66, 76, 87, 160	Removal of males	65
Mating ratios	87	Rendering	151
Maturity	9, 10, 51	Repairs and maintenance	147
Metabolic disorders	136	Respiratory disease	20
Migration	117	Rots and bangers	106
Minerals	136	Rodent	110, 140, 144, 145
Misting	17	Salmonella	144, 155
Monitoring body	44, 45, 97	Sample weighing	79, 83, 164
Monitoring	20, 57, 59, 72, 75, 77, 115	Sampling of feed	141
Mycoplasmosis	155	Sanitization	144, 147
Mycotoxin	136	SDS Sudden Death Syndrome	136
Natural environment	121, 125	Seasonality	129, 130
Nests	57, 58, 102	Sediment in water	149
Normal distribution	29	Sensors for environment	20
Nutrient composition of feeds	133, 140, 172	Separate sex feeding	52, 54, 55, 139
Nutrient intake	49, 61, 133, 139	Serological monitoring	155
Nutrient recommendations	67, 133, 135, 138, 139, 142	Sexing errors	52, 53
		Sexual maturity	44, 48, 51, 87, 123, 127
		Shank length	86
		Shell quality	135

Site	149
Skeleton	86
Sodium	136
Spin feeders	25
Spot brooding	14
Spray cooling	119
Standard deviation	34
Starter feed	137
Stocking density	15, 17, 23, 47, 109, 143, 159
Storage of eggs	104
Synchronization of males and females	48, 123, 125
Target performance	70, 71, 72
Target weight	31, 33, 42, 43, 48, 69, 75, 83, 122, 126, 128, 130, 165
Target parameters	158
Temperature gradient	15, 18
Temperature of eggs	104
Temperature	13, 18, 19, 110, 116, 117, 139, 163
Timer for ventilation	113
Toast rack feeder	54
Trace minerals	136
Track feeder	24
Transfer from rear to lay	50
Transitional ventilation	116
Transportation of chicks	11, 16
Tube feeders	55
Tunnel ventilation	117
Under-feeding	62
Underweight birds	43, 45, 48, 64
Uniformity	10, 24, 29, 30, 40, 48, 79, 122
UV	131, 149
Vaccination programs	143, 152, 153, 156
Variation in population	29, 30, 35, 37
Vehicle cleaning	13
Vent (cloaca)	87, 93
Ventilation calculations	118, 168
Ventilation	20, 111-113, 116, 160, 163
Visitors	144
Vitamins	136, 173
Vocalization	21
Walk-through	58, 60, 85, 86, 87, 94
Washing eggs	104
Washing houses	146
Water quality	27, 149, 150
Water	13, 14, 27, 28, 136, 142, 147, 149, 152
Water:feed ratio	142, 160
Wattles and comb	51, 92
Wavelength	131
Weigh scales	31, 34, 77
Weight profile	33, 39, 82
Weight recording manually	80
Welfare	2, 10, 17, 23, 47, 65, 92, 107, 109, 111, 120, 122, 133, 134, 139, 143, 145, 148, 152, 152, 154, 155
Whole-house brooding	15, 16
Wind chill	20
Wind speed	117
Worms (helminths)	154



Every attempt has been made to ensure the accuracy and relevance of the information presented. However, Aviagen accepts no liability for the consequences of using the information for the management of chickens.

For further information on the management of Ross stock, please contact your local Technical Service Manager or the Technical Services Department.